

Renewable Energy



AGRIMOON.COM

All About Agriculture...

Renewable Energy

ICAR e-Course
For
B.Sc (Agriculture) and B.Tech (Agriculture)



AGRIMOON.COM

All About Agriculture...

INDEX

Lecture	Page No
Module –I Overview of renewable energy sources	
Lecture-1. Classification of energy sources	5-9
Lecture-2.Introduction to renewable energy	10-25
Lecture 3.Renewable Energy-Potentials and Achievements	26-37
Module –II Characterization of Biomass	
Lecture-4.Characterization of biomass	38-43
Lecture-5.Densification of biomass-Briquetting	44-50
Module –III Thermo-chemical conversion Technology (TCCT)	
Lecture-6. Biomass Combustion Technology	51-60
Lecture-7.Gasifier Technology	61-70
Lecture-8.Biomass Gasification Methods	71-78
Lecture-9. Removal of tar and impurities from gasification	79-80
Lecture 10- Principles of pyrolysis and methods	81-88
Module –IV Biochemical conversion Technology-Biogas (BCCT)	
Lecture-11.Biogas technology	89-97
Lecture-12. Biogas plants types	98-104
Lecture 13. Microbiology of biogas production	105-117
Lecture 14. Size and selection for Biogas plant	118-120
Lecture 15.Biogas plant- materials and methods for Construction	121-128

Module –V Bio-fuels (BCCT)

Lecture 16.Bio-Fuels and characteristics	129-135
Lecture- 17.Bio-Diesel	136-139
Lecture-18.Bio-Diesel production processes	140-149
Lecture-19.Bio-Ethanol Production	150-156
Lecture-20.Importance of biofuels	157-158

Module –VI Solar Energy Conversion System (SECS)

Lecture-21.Basics of Solar Photovoltaic's	159-164
Lecture 22.Recent trends in solar drying-solar tunnel drier	165-167
Lecture- 23.Solar Driers	168-170
Lecture-24.Solar PV and water pumping	171-173
Lecture- 25.Solar Water Heater	174-177

Module –VII Hydro-Energy Conversion System (HECS)

Lecture-26-Hydropower Energy Sources	178-183
--------------------------------------	----------------

Module –VIII Wind Energy Conversion System (WECS)

Lecture-27-Wind energy conversion principles	184-188
Lecture 28-wind mill- aero generator	189-199

Module-IX. Energy conservation in agriculture

Lecture-29. Energy conservation in agriculture	200-208
--	----------------

LECTURE-1 Classification of Energy sources

About 70% of India's energy generation capacity is from fossil fuels, with coal accounting for 40% of India's total energy consumption followed by crude oil and natural gas at 24% and 6% respectively. India is largely dependent on fossil fuel imports to meet its energy demands — by 2030, India's dependence on energy imports is expected to exceed 53% of the country's total energy consumption. In 2009-10, the country imported 159.26 million tonnes of crude oil which amount to 80% of its domestic crude oil consumption and 31% of the country's total imports are oil imports. The growth of electricity generation in India has been hindered by domestic coal shortages and as a consequence, India's coal imports for electricity generation increased by 18% in 2010.

Due to rapid economic expansion, India has one of the world's fastest growing energy markets and is expected to be the second-largest contributor to the increase in global energy demand by 2035, accounting for 18% of the rise in global energy consumption. Given India's growing energy demands and limited domestic fossil fuel reserves, the country has ambitious plans to expand its renewable and nuclear power industries. India has the world's fifth largest wind power market and plans to add about 20GW of solar power capacity by 2022. India also envisages to increase the contribution of nuclear power to overall electricity generation capacity from 4.2% to 9% within 25 years. The country has five nuclear reactors under construction (third highest in the world) and plans to construct 18 additional nuclear reactors (second highest in the world) by 2025.

Types of Energy

Basically energy can be classified into two types:

Potential Energy

Kinetic Energy

Potential Energy

Potential energy is stored energy and the energy of position (gravitational). It exists in various forms.

Kinetic Energy

Kinetic energy is energy in motion- the motion of waves, electrons, atoms, molecules and substances. It exists in various forms.

Various Forms of Energy

Chemical Energy

Chemical energy is the energy stored in the bonds of atoms and molecules. Biomass, petroleum, natural gas, propane and coal are examples of stored chemical energy.

Nuclear Energy

Nuclear energy is the energy stored in the nucleus of an atom - the energy that holds the nucleus together. The nucleus of a uranium atom is an example of nuclear energy.

Stored Mechanical Energy

Stored mechanical energy is energy stored in objects by the application of a force. Compressed springs and stretched rubber bands are examples of stored mechanical energy.

Gravitational Energy

Gravitational energy is the energy of place or position. Water in a reservoir behind a hydropower dam is an example of gravitational energy. When the water is released to spin turbines, it becomes rotational energy.

Radiant Energy

Radiant energy is electromagnetic energy that travels in transverse waves. Radiant energy includes visible light, x-rays, gamma rays and radio waves. Solar energy is an example of radiant energy.

Thermal Energy

Thermal energy (or heat) is the internal energy in substances- the vibration and movement of atoms and molecules within substances. Geothermal energy is an example of thermal energy.

Electrical Energy

Electrical energy is the movement of electrons. Lightning and electricity are examples of electrical energy.

Motion

The movement of objects or substances from one place to another is motion. Wind and hydropower are examples of motion.

Sound

Sound is the movement of energy through substances in longitudinal (compression/rarefaction) waves.

Light Energy

Light energy is a type of wave motion. That is, light is a form of energy caused by light waves. It enables us to see, as objects are only visible when they reflect light into our eyes

Nuclear Energy

Nuclear energy is a controversial energy source. It is not a renewable energy source, but because it is a technology not based on fossil fuels many people think nuclear power plants could play an important role in reducing carbon emissions and battling climate change. However, many others feel the risk of accidents and the issues of storing nuclear waste for thousands of years are too significant to warrant the development of this energy source.

Classification of energy resources

The various sources of energy can be conveniently grouped as

Commercial primary energy resources: Non-renewable sources of energy or conventional sources of energy are being accumulated in nature for a very long time and can't be replaced if exhausted. Nature gifted resources which are consumed can't be replaced. Eg: coal, petroleum, natural gas, thermal power, hydro power and nuclear power are the main conventional sources of energy.

Renewable sources of energy: Energy sources, which are continuously and freely produced in the nature and are not exhaustible are known as the renewable sources of energy. Eg: solar energy, biomass and wood energy, geo thermal energy, wind energy, tidal energy and ocean energy. But main attention has to be directed to the following sources of renewable namely, a) solar photovoltaic, b) wind, and c) hydrogen fuel cell.

New sources of energy: The new sources of energy are available for local exploitation. In many cases, autonomous and small power plants can be built to avoid transmission losses. Most prominent new sources of energy are tidal energy, ocean waves, OTEC, peat, tar sand, oil shales, coal tar, geo thermal energy, draught animals, agricultural residues etc., The total energy production in India is 14559×10^{15} joules. 93% of India's requirement of commercial energy is being met by fossil fuels, with coal contributing 56%, and oil and natural gas contributing 37%. Waterpower and nuclear power contributing only 7% of total energy production. Comparing the total energy

Renewable Energy

production in India from commercial sources with that of world, it is only 3.5% of total world production.

Energy resource	Advantages	Disadvantages
Fossil fuels	Provide a large amount of thermal energy per unit of mass Easy to get and easy to transport Can be used to generate electrical energy and make products, such as plastic	Nonrenewable Burning produces smog Burning coal releases substances that can cause acid precipitation Risk of oil spills
Nuclear	Very concentrated form of energy Power plants do not produce smog	Produces radioactive waste Radioactive elements are nonrenewable
Solar	Almost limitless source of energy Does not produce air pollution	Expensive to use for large-scale energy production Only practical in sunny areas
Water	Renewable Does not produce air pollution	Dams disrupt a river's ecosystem available only in areas that have rivers
Wind	Renewable Relatively inexpensive to generate Does not produce air pollution	Only practical in windy areas
Geothermal	Almost limitless source of energy Power plant require little land	Only practical areas near hot spots Waste water can damage soil
Biomass	Renewable	Requires large area of farmland Produces smoke

Total Installed Capacity (June 2012)

Source	Total Capacity (MW)	Percentage
Coal	116,333.38	56.65
Hydroelectricity	39,291.40	19.13
Renewable energy source	24,832.68	12.09
Gas	18,903.05	9.20
Nuclear	4780	2.32
Oil	1,199.75	0.58
Total	2,05,340.26	

Sector	Total Capacity (MW)	Percentage
State Sector	86,275.40	42.01
Central Sector	62,073.63	30.22
Private Sector	56,991.23	27.75
Total	2,05,340.26	

Lecture-2 Introduction to renewable energy sources

Renewable energy sources derive their energy from existing flows of energy from on-going natural processes, such as sunshine, wind, flowing water, biological processes, and geothermal heat flows. A general definition of renewable energy sources is that renewable energy is captured from an energy resource that is replaced rapidly by a natural process such as power generated from the sun or from the wind. Currently, the most promising (aka economically most feasible) alternative energy sources include wind power, solar power, and hydroelectric power. Other renewable sources include geothermal and ocean energies, as well as biomass and ethanol as renewable fuels.

Solar

The recent disasters in the southeastern United States highlighted the decline in the world's oil supply, forcing us to begin considering other energy options. One promising technology, solar power is worth considering for its sustainable, renewable and emissions reducing qualities. Modern residential solar power systems use photovoltaic (PV) to collect the sun's energy. "Photo" means "produced by light," and "voltaic" is "electricity produced by a chemical reaction." PV cells use solar energy to generate a chemical reaction that produces electricity. Each cell contains a semiconductor; most commonly silicon in one of several forms (single-crystalline, multi-crystalline, or thin-layer), with impurities (either boron or phosphorus) diffused throughout, and is covered with a silk screen. Cells are joined together by a circuit and frame into a module. Semiconductors allow the electrons freed from impurities by the sun's rays to move rapidly and into the circuit, generating electricity. Commercial residential PV modules range in power output from 10 watts to 300 watts, in a direct current. A PV module must have an inverter to change the DC electricity into alternating current energy in order to be usable by electrical devices and compatible with the electric grid. PV modules can also be used en masse to create large-scale power plants.

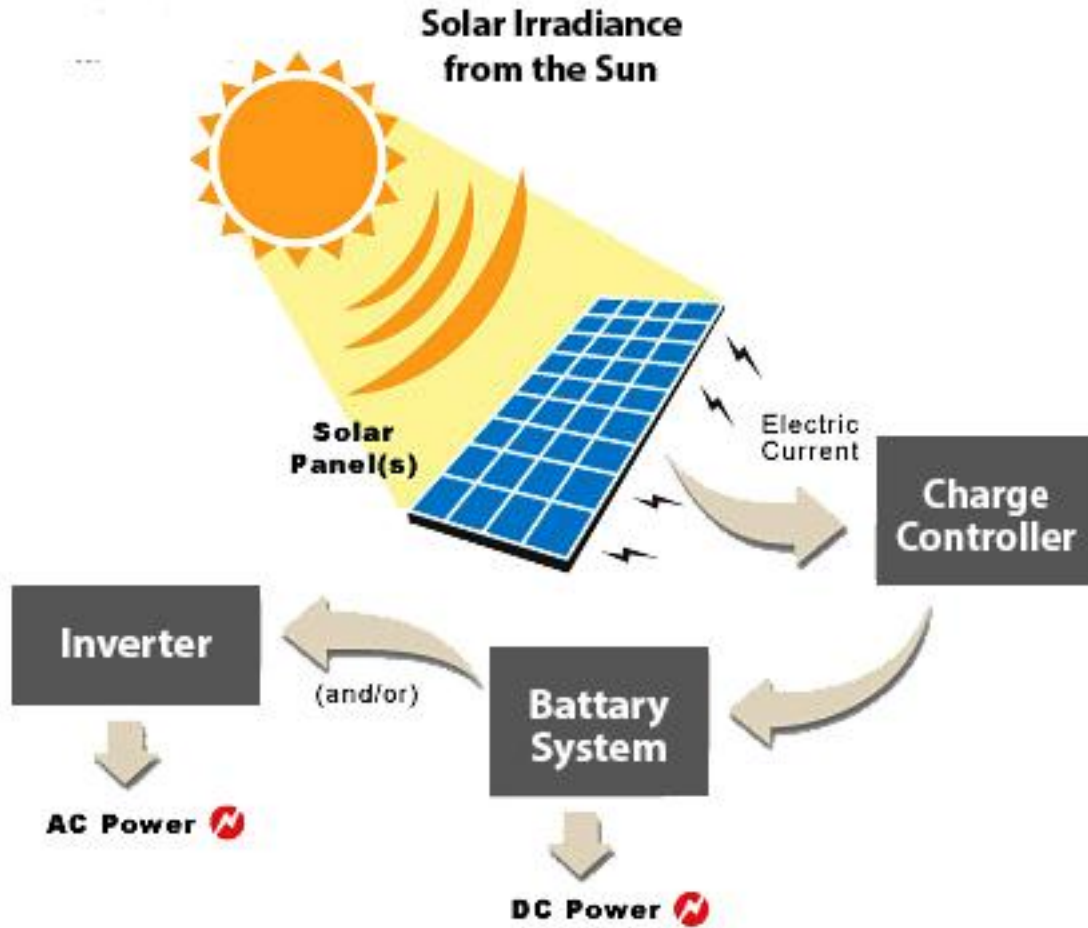

Using PV modules to generate electricity can significantly reduce pollution. The most energy used in creating solar panels is used to purify and crystallize the semiconductor material. No official numbers are available on the exact amount of energy used to create solar panels because there is no industry standard for making the crystals. A number of researchers have done work in attempt to address concerns about energy payback for PV systems. Assuming 12% conversion efficiency and 1,700 kWh/m² of sunlight per year, the estimates range between 2 and 4 years for rooftop PV systems to generate the energy it took to make them.⁴⁴ The average United States household uses 830 kWh of electricity per month. Over twenty years, a 100-megawatt solar thermal electric power plant can avoid producing over three million tons of carbon dioxide. Estimates regarding pollution prevention suggest that producing 1,000 kWh of electricity through solar power can reduce emissions by 8 pounds of sulfur dioxide, 5 pounds of nitrogen oxide, and 1,400 pounds of carbon dioxide. Lifetime estimates (over a projected 28 years) average in the thousands of pounds of prevented emissions. Installing a PV system is a hefty

Renewable Energy

investment for homeowners. 5-kW systems can cost up to \$40,000. PV system power can cost as much as \$9 per watt, and small systems will not produce enough power to offset electricity costs and save the homeowner any substantial money. As a result, over 30 states offer incentives (mostly in the form of tax rebates) to help encourage homeowners to purchase and install PV systems. California is one of the key states, receiving a huge amount of radiation, with the better part of the industry located there, and high-energy costs. The state of California offers a number of incentives under the Emerging Renewables Program passed by the state legislature. The California Energy Commission offers a rebate of \$4 per watt to help homeowners affordably install PV systems. However, the mortgage financing required to purchase a realistic PV system is still quite substantial. As PV technology advances, more efficient, easily affordable, standardized, reliable and longer-lasting modules will become available. PV systems' value to the energy sector especially in residential capacities, is increasingly apparent. However, the continued high cost means that many homeowners will be deterred from purchasing and installing PV systems. The only way to encourage further growth in this sector is for consumers to purchase such systems. The energy emissions reductions are substantial enough to be worth the consideration of the federal government. In order to encourage consumers' interest in PV systems and growth in the renewable energy sector at a faster rate, the federal government should create an incentive program to help homeowners and businesses purchase and install PV systems, especially on new constructions.

Wind

Wind energy is one of the most promising alternative energy technologies of the future. Throughout recent years, the amount of energy produced by wind-driven turbines has increased exponentially due to significant breakthroughs in turbine technologies, making wind power economically compatible with conventional sources of energy. Wind energy is a clean and renewable source of power. The use of windmills to generate energy has been utilized as early as 5000 B.C., but the development of wind energy to produce electricity was sparked by the industrialization. The new windmills, also known as wind turbines, appeared in Denmark as early as 1890. The popularity of wind energy however has always depended on the price of fossil

Renewable Energy

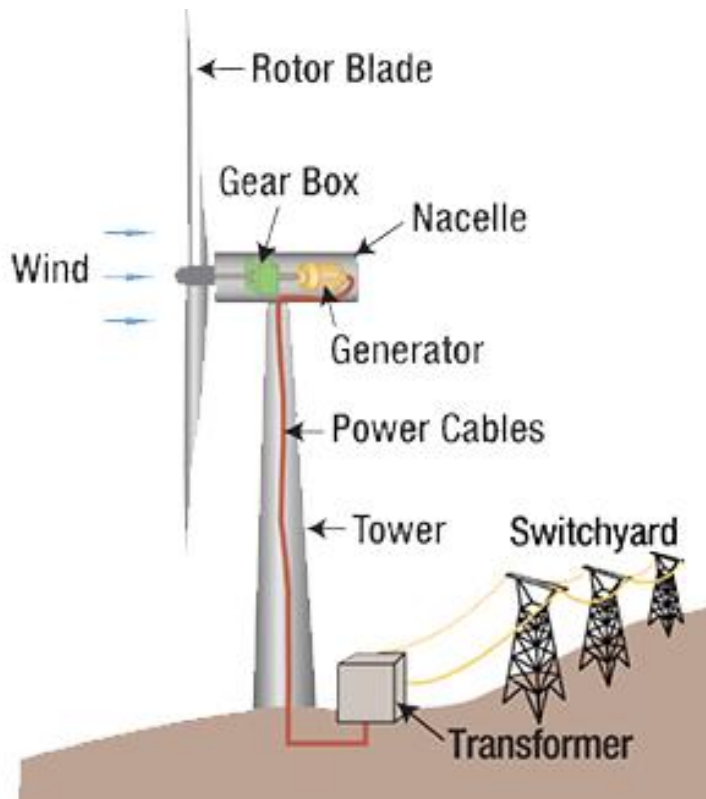

fuels. For example, after World War II, when oil prices were low, there was hardly any interest in wind power.

However, when the oil prices increased dramatically in the 1970s, so did worldwide interest in the development of commercial use of electrical wind turbines. Today, the wind-generated electricity is very close in cost to the power from conventional utility generation in some locations.

Where does wind come from? Wind

is a form of solar energy and is caused by the uneven heating of the atmosphere by the Sun, the irregularities of the Earth's surface, and rotation of the Earth. The amount and speed of wind depends on the Earth's terrain and other factors. The wind turbines use the kinetic energy of the wind and convert that energy into mechanical energy, which in turn can be converted into electricity by means of a generator. 2

There are essentially two types of wind turbines: The horizontal-axis variety, and the vertical-axis design. The horizontal-axis design is used more commonly and looks like an Old Dutch windmill, whereas the vertical-axis design looks like an eggbeater. These wind turbines generally have either two or three blades, called rotors, which are angled at a pitch to maximize the rotation of the rotors. The horizontal-axis design is slightly more efficient and dependable than the vertical-axis windmill. Most of the windmill models that are currently in production are thus horizontal-axis windmills.

Utility scale turbines can produce anywhere from 50 kilowatts to several megawatts of energy. These large windmills are generally grouped together in a windy area in what is called a wind

Renewable Energy

farm. The proximity of the windmills in a wind farm makes it easier to feed the produced electricity into the power grid. Wind energy offers many advantages compared to fossil based power and even some other types of alternative energy, which explains why it is the fastest growing energy source in the world. The two main reasons are cleanliness and abundance. The fact that wind is a renewable resource gives it a major advantage over oil and the nonrenewable resources. Considering that environmental pollution is being linked to several global problems that might eventually threaten the existence or at the very least worsen human living conditions, the fact that windmills do not produce any emissions whatsoever is another reason to increase the use of wind turbines. Increasing the percentage of wind power used by the United States would not be unreasonable, seeing that the price of wind power is between 4 and 6 cents.

Even though wind energy has many environmental and supply advantages, there are several disadvantages that limit the usability of wind power. The main disadvantage to wind power is that it is unreliable. Wind does not blow at a constant rate, and it does not always blow when energy is needed. Furthermore, the windiest locations are often in remote locations, far away from big cities where the electricity is needed. Just like with any other energy plant, people oppose it because of aesthetic reasons. The rotor noise produced by the rotor blades is another reason for opposition.

Wind seems to be a very good source of alternative energy. Its biggest setback is its unreliability, but in combination with other, more reliable sources, wind energy should be used extensively to supplement the demand for energy.

Hydroelectric Power

Hydropower is America's leading renewable energy resource. This notable success can be attributed to the fact that out of all the renewable power sources, hydropower the most reliable, efficient, and economical. Furthermore, the concept behind hydroelectric power is fairly simple and has been in use for a significant span of time.

The earliest reference to the use of the energy of falling water is found in the work of the Greek poet Antipater in the 4th century BC. Indeed, the word "hydro" comes from the Greek language meaning "water." Several centuries later, the Romans were the first to utilize the waterwheel. Due to the Romans' powerful influence on Europe through conquest, the waterwheel was soon

Renewable Energy

commonly found throughout that continent, and by 1800, tens of thousands of waterwheels had been built. These early waterwheels were of course not used for power generation, but mostly for grinding crops. Water energy was first converted into electricity on Sept. 30, 1882 near Appleton, Wisconsin.⁸ By 1980 hydroelectric power accounted for about 25% of global electricity and 5% of total world energy use, which amounted to approximately 2,044 billion kilowatt hours (kW h).

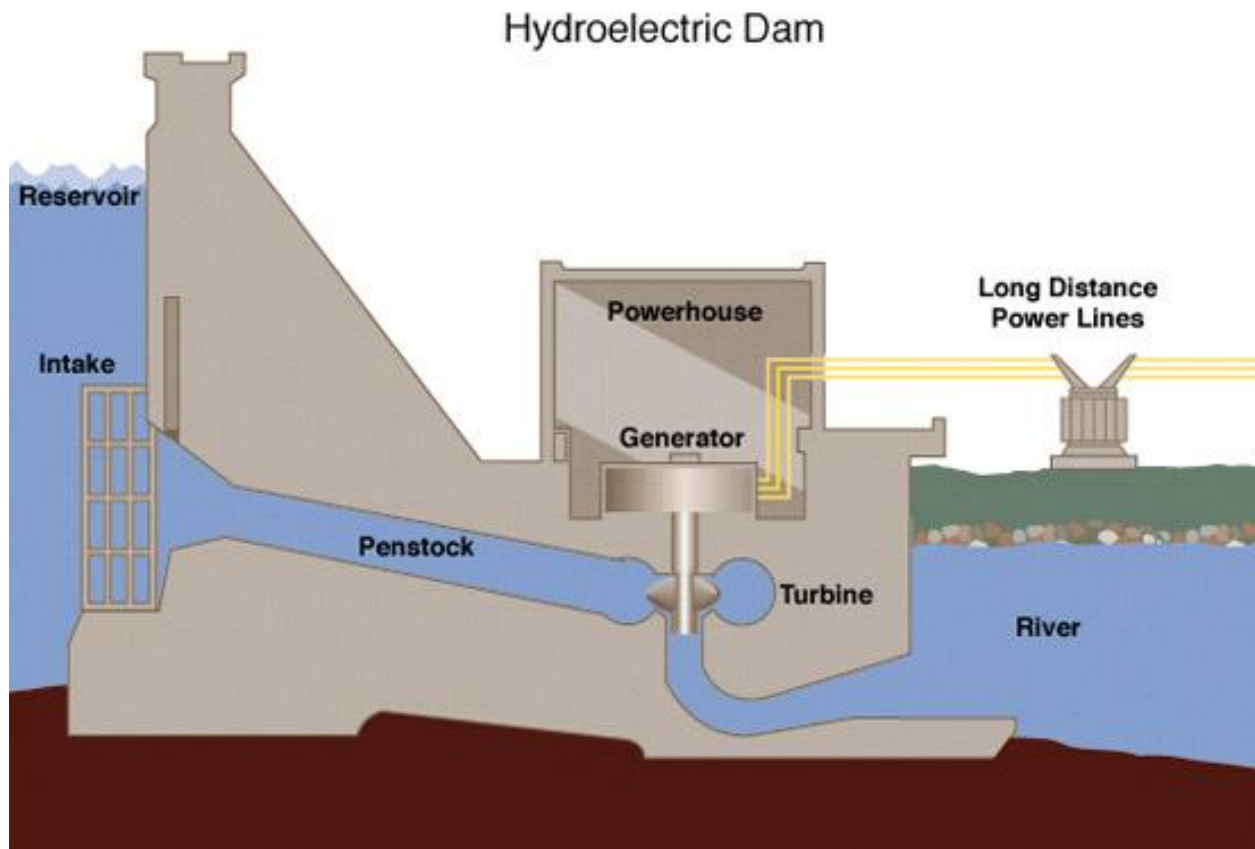

Harvesting energy from water is possible due to the gravitational potential energy stored in water. As water flows from a high potential energy (high ground) to lower potential energy (lower ground), the potential energy difference thereby created can be partially converted into kinetic, and in this case electric, energy through the use of a generator. There are essentially two major designs in use that utilize water to produce electricity: the hydroelectric dam, and the

Renewable Energy

pumped-storage plant. The waterwheel discussed at the beginning of this paper is currently no longer in use and has been replaced by the far more economical and efficient dam. Both the waterwheel and the dam work on the same general principle, but the dam has the advantage of being more reliable due to the reservoir behind it. The principle is simple: the force of the water being released from the reservoir through the penstock of the dam spins the blades of a turbine. The turbine is connected to the generator that produces electricity. After passing through the turbine, the water reenters the river on the downstream side of the dam. A pumped-storage plant is very similar to the hydroelectric dam, the main difference being that the pumped-storage plant uses two reservoirs, one being considerably higher than the other. The advantage of this design is that during periods of low demand for electricity, such as nights and weekends, energy is stored by reversing the turbines and pumping water from the lower to the upper reservoir. The stored water can later be released to turn the turbines and generate electricity as it flows back into the lower reservoir. Now that the two types of facilities have been discussed, there are also two way of obtaining the water: dam and run-of-the-river. A dam raises the water level of a stream or river to an elevation needed to create the necessary water pressure. In a run-of-the river scenario, the water is diverted from its natural path, enters the turbine, and is later returned to the river. Hydroelectric power offers several significant advantages compared to fossil based power, and even other types of alternative energy. Probably the most important asset of hydroelectric power is its reliability. Furthermore, it creates no pollution, and once the dam is built, even though that process is very expensive, the produced energy is virtually free. A dam has the ability to continuously produce electricity and can adjust to peaks in demand by storing water above the dam and by being able to increase production to full capacity very quickly. Other than the high construction and planning costs, the major drawbacks of large dams are mostly environmental. The dam does not produce harmful emissions as in the case of fossil fuel burning. It does however alter the landscape dramatically, producing several severe, even unbearable changes to the habitat of fish and other plants and animals. Building a large dam will of course flood a large area of land upstream of the dam, causing problems for the animals that used to live there. It furthermore affects the water quantity and quality downstream of the dam which in turn affects plants and animals. Blocking the river also disallows certain migration pattern of fish. Finding sites that are suitable for dams is also a challenge. This is one of the reasons why the hydroelectric power production in the U.S. cannot increase by much in the future: most of the

Renewable Energy

suitable locations have already been utilized. According to the Energy Information Administration, the total amount of electricity produced in the U.S. through hydroelectric means has increased by 6.3% from 2004 to 2005. Even though U.S. construction of dams has peaked and is decreasing, advances in turbine technology maintain a slight growth margin of electricity production. Precipitation however also influences the ability of dams to produce electricity. In this sense, 2005 could have been a year of increased precipitation if compared to 2004. Overall, hydroelectric power seems to be a very good source of alternative energy: one that should be maintained at the maximum level possible. It has the main advantage over all the other forms of alternative energy production in that it is reliable, whereas the other forms of alternative energy are not. The main disadvantage is that hydroelectric energy production in the U.S. is currently being used to its maximum potential, which means that large sums of investment will produce only small increases productivity. Other alternative energy sources are not yet as developed and hence will produce greater advances in productivity with the same or even a smaller input of money. Hydroelectric spending should be maintained at current levels, and more money should be invested in the other sources of alternative energy.

Geothermal

Geothermal energy is one of the only renewable energy sources not dependent on the Sun. Instead, it relies on heat produced under the surface of the Earth. Geothermal energy already has several applications and could potentially provide a significant source of renewable power for the United States. However, it is limited by a multitude of factors revolving around the issues of sustainability and economics. There are two main applications of geothermal energy, which include producing electricity at specialized power plants, and direct-heating, which puts to direct use the temperature of water piped under the earth's surface. Geothermal power plants take on several types of forms, depending on the type of geothermal area from which they extract energy. In any case, the plants depend on steam to power turbines and generate electricity, though the methods of producing steam varies depending on the type of geothermal reservoir.¹² Direct-heating, on the other hand, provides immediate, usable energy. This type of energy can heat individual buildings or entire areas, as in the city of Klamath Falls, Oregon. It can also cool buildings by pumping water underground where the temperature remains relatively stable near 60 degrees Fahrenheit, and then into buildings, where the water absorbs heat, thus helping to air condition the building. The United States also uses direct heating in fish farms, spas, and

Renewable Energy

greenhouses. Geothermal energy could potentially become a major source of renewable power for the United States. This is because geothermal energy reduces the United States dependence on foreign oil, it's extremely reliable due to the constant source of heat emanating from the earth, and it has almost no negative environmental impact.¹⁵ In 2004, the US produced approximately 2300 MW of electricity, and the Department of Energy estimates that the figure could reach 15000 MW per year within a decade.¹⁶ In the grander scheme, however, geothermal energy accounted for only about 0.34% of total U.S. energy consumption, and 5.56% of renewable energy consumption.¹⁷ But more energy could be extracted using developing technology, which doesn't rely on existing hot water and steam reservoirs. The process involves drilling deep into the surface of the Earth

where temperatures are hot, and then injecting water into cracks of rock, which is heated and then pumped back to the surface.¹⁸ If this "hot dry rock" (HDR) technology proves effective, then more geothermal plants could operate in more locations, since much of the Earth's surface is underlain by hot, dry

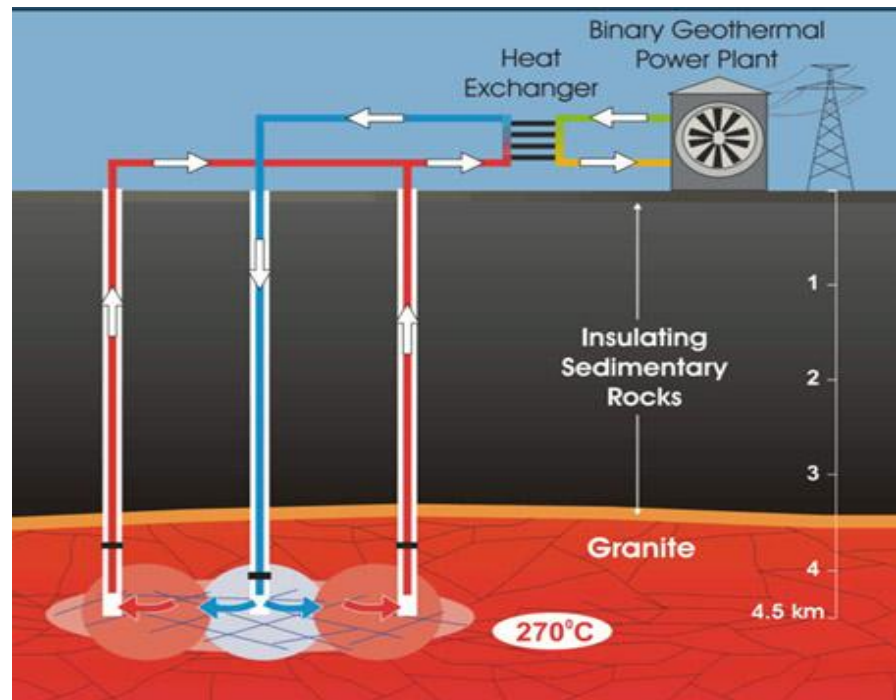

rock. Some problems that geothermal energy faces are depletion of both water and heat in geothermal areas. The first problem has been partially addressed by re-injecting water into reservoirs, thus sustaining the plant's ability to operate. However, it has been shown that water re-injection can cause small earthquakes, which raises the question of whether the plants should be liable for the damages caused.¹⁹ In Alameda, California, water reinjection at a geothermal power plant triggered earthquakes of magnitudes up to 3.9 and 3.5 on the Richter scale, which were felt 90 miles away in the community of Middletown.

Renewable Energy

As of now, there is no government regulation concerning the repayment of damages caused by these earthquakes, though community groups such as the one in Middletown have pressured the plant to compensate homeowners for damages such as cracked chimneys, which can cost about \$10,000 to fix.²⁰ Heat depletion of geothermal areas is more problematic than water depletion in the long run, since it cannot be avoided. It is caused by a natural cooling-off of the earth's crust, and in these cases, plants would become less and less efficient over several decades until they were rendered useless. Other issues facing geothermal power in the United States are building costs and economic competitiveness with other energy sources. Geothermal plants can be expensive, depending on factors such as how deep the wells must be drilled and the temperature of the water or steam. These initial costs of an economically competitive plant can be as high as \$2800 per kW installed capacity, which accounts for about two thirds of total costs for the plant. The plants are economically competitive in the long run however, because their fuel is free, whereas natural gas or coal plants spend up to two thirds of their total operating costs on fuel. Another problem that adds cost to geothermal plants is the problem of connecting to energy grids. This is a critical issue because geothermal plants are built where geothermal resources permit- such as geysers and areas with less-heated water. Over time, however, the plants pay for themselves and all the necessary costs because of low operating costs; namely, the fact that the plants energy is free and always available. The National Commission on Energy Policy believes geothermal energy can cost from 4-6 cents per kWh, which depends on the construction of new geothermal plants, but compares favorably with other renewable energies such as solar power, which costs 20-25 cents per kWh.²² It's also competitive with coal and natural gas, which costs about 4-5 cents per kWh.²³ The projected low cost therefore depends on the availability and exploitation of existing geothermal resource. Because of its reliability, accessibility, low impact on the environment, and potential low cost, geothermal energy is a very attractive source of renewable energy for the United States. Expanding use of geothermal energy depends largely upon the success of the hot dry rock technology and the simultaneous prevention of earthquakes caused by water injection at those plants and water re-injection at other plants. If the HDR technology proves to be viable and safe, geothermal plants can be built in closer proximity to electricity grids, without worrying about geothermal resources like geysers. This would make the plants more cost effective and enable geothermal energy to compete with other energy types.

Biomass

As a pending global energy crisis appears more and more imminent, it is important to consider many different options for new energy sources. Renewable energy sources are ideal because they are more efficient, environmentally friendly and, ultimately, better for consumers. Biomass can be converted into fuels through a number of different processes, including solid fuel combustion, digestion, pyrolysis, and fermentation and catalyzed reactions. Electricity is generated in many places through solid fuel combustion. The majority of America's electricity is fueled by coal combustion. However, many states, especially California, are encouraging companies to use biomass fuels to generate electricity. These products are usually wood matter, vegetation, waste from lumber yards, and the like.²⁵ Power plants burn such fuels to heat a boiler, and the resulting steam powers turbines & generators.²⁶ This process still releases a lot of carbon dioxide and other polluting gases into the environment, but helps eliminate waste efficiently.

Digestion is another process that makes use of existing waste. The term is a misnomer. Digestion is the naturally occurring process of bacteria feeding on decaying matter and making it decompose. It is that which releases gases like methane, hydrogen, carbon monoxide, etc.²⁷ In many landfills, owners are experimenting with set-ups to best collect the gases produced by such bacteria. The standard system includes pipelines running through the waste to collect the gases. Animal feed lots and other facilities are also exploring tapping such resources. A zoo in upstate New York is using their elephant manure to do the same thing. Benefits of this process include the relative lack of impurities in the gases produced and the fact that the synthesis gases (carbon monoxide and hydrogen) can be converted to any kind of hydrocarbon fuel.

A third process, pyrolysis, creates a product much like charcoal, with double the energy density of the original biomass, making the fuel highly transportable and more efficient. Anhydrous pyrolysis heats the biomass at intense temperatures in the absence of oxygen or water. Scientists assume that this is the process that originally produced fossil fuels (under different conditions). Most industrial processes of pyrolysis convert the biomass under pressure and at temperatures above 800° F (430° C). A liquid fuel can also be produced using this process.

The most widely used alternative fuel, ethanol, is created through fermentation of organic materials. Ethanol has a current capacity of 1.8 billion gallons per year, based on starch crops

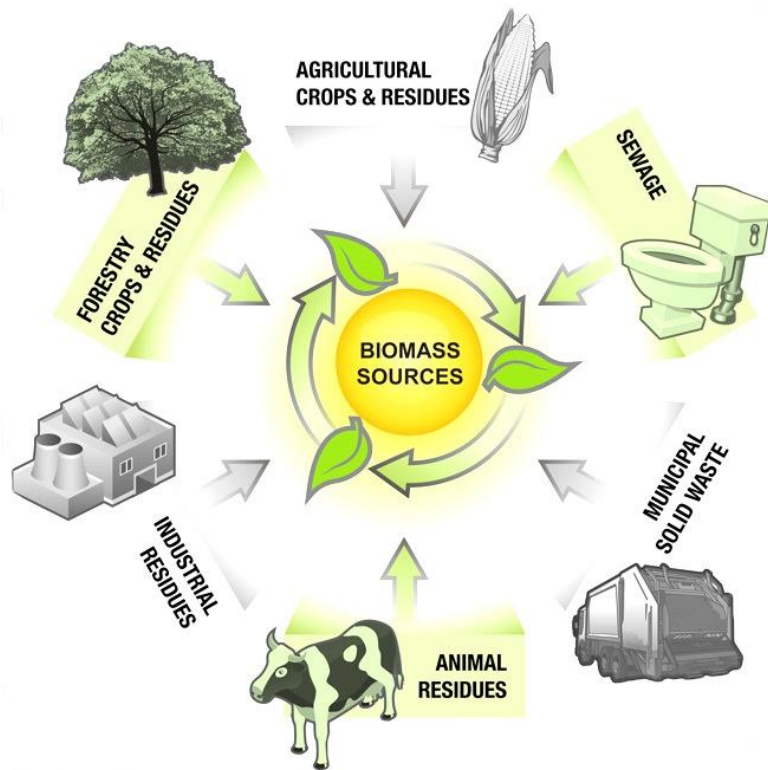

such as corn. Again, the fuel conversion process takes advantage of a natural process. Microorganisms, especially bacteria and yeasts, ferment starchy, sugary biomass products (like corn), yielding products like ethanol, which can be used as fuels in a variety of applications. Biodiesel is an increasingly popular fuel, especially in the transportation sector. This mono-alkyl ester is formed by combining fuel-grade oil, processed from sources like

vegetable oil, animal fats, algae and even used cooking grease, with an alcohol (like methanol or ethanol), using a catalyst. It shows great promise as both a neat fuel (used alone) and as an additive to petroleum diesel.

Using biomass could be the answer to the energy questions made more imminent by the recent crises that have further threatened our oil supply. The current technologies take advantage of many natural, long-utilized processes in order to create “new” kinds of fuel. Upon further observation, one realizes that these fuels are very basic, using the most readily available energy sources with very simple, standardized processes that greatly reduce pollution and offer hope for the future.

Ethanol

Fuel-quality ethanol is beneficial for car-owners, the economy and the environment. This growing technology is looking to be an immediate part of the solution to the forthcoming energy crisis. Ethanol, also known as ethyl alcohol or grain alcohol, is a colorless, clear liquid. The chemical formula is $\text{CH}_3\text{CH}_2\text{OH}$. Fuel-quality ethanol goes through more processes than do

Renewable Energy

alcoholic beverages, in order to make it unfit for human consumption and to increase the purity so as to avoid separation when mixed with gasoline. The most common method for making ethanol used in the United States is the dry-mill method. At the beginning of 2005, the 81 ethanol plants in 20 states can produce up to 4.4 billion gallons each year, and the 16 plants under construction are expected to add 750 million gallons of capacity. The dry mill process has advanced to the point at which any cellulosic (plant fiber) biomass can be used to make fuel ethanol (and is now being referred to as the Advanced Bioethanol Technology). The variety of feedstock that can be used today includes corn, barley, wheat, cornstalks, rice straw, sugar cane bagasse, pulpwood, switch grass and even municipal solid waste, offering tremendous opportunities for new jobs and economic growth.

Ethanol is not used by itself to fuel cars. Instead, it's mixed with gasoline. The two most common blends are E10 and E85. The number refers to the percentage of ethanol in the blend. E10 is a blend of ten percent ethanol and ninety percent gasoline. E85, the most mainstream alternative fuel, is eighty-five percent ethanol and fifteen percent gasoline. Using ethanol increases the octane rating and decreases the amount of damaging emissions associated with fuel consumption. It is for this second reason that ethanol use is so strongly recommended and endorsed by state and federal governments. The Clean Air Acts Amendments of 1990 require using reformulated gasoline (RFG) to reduce emissions in major metropolitan areas. RFG blends gasoline with oxygenates, of which ethanol is increasingly popular. Methyl tertiary-butyl ether (MTBE) used to be the most popular, but there are increasing environmental health concerns, regarding seepage, surrounding its use. Oxygenates (compounds with structures similar to that of gasoline, but with the addition of oxygen) dilute the noxious, dangerous gases emitted by gasoline consumption, including nitrogenous oxides, volatile organic compounds and other toxic like carbon monoxide. It is for this reason that the Clean Air Acts Amendments require inclusion of oxygenates like ethanol in the fuel supplies of metropolitan areas, and that the government offers many incentives. These include the Clean Fuel Tax Deduction, taken off the vehicle property tax on new qualified clean fuel vehicles or the conversion of vehicles to run on alternative fuels; the ethanol and biodiesel tax credit, under the American Jobs Creation Act of 2004 (Public Law 108-357); the credit for installation of alternative fueling stations, under the Energy Bill of 2005; the new Flexible Fuel Vehicle labeling requirement, and many more. Approximately one-third of the states offer incentives as well.

Renewable Energy

Increase in use of ethanol as fuel will benefit farmers economically. The majority of ethanol used today comes from corn, and it is the farmer-owned ethanol plants that are driving the industry's growth. Half of the operating plants are owned by farmers and local investors. The United States Department of Agriculture estimates that the Renewable Fuels Standard would increase the demand for corn for ethanol to 2 billion bushels each year by 2012, almost double the current demand, which would raise net farm income to \$4 billion.

There are drawbacks to using ethanol. The presence of oxygen and smaller molecules means it produces less energy than raw gas, reducing fuel economy by 2 to 3 percent. The octane boost from ethanol is smaller than that of MTBE, and ethanol raises gasoline's volatility, increasing evaporative emissions, all of which are of concern. However, these shortcomings pale in comparison to the health concerns and need to reduce the use of gasoline consumption. There is a reason ethanol blend is required in fuel by Minnesota state law. The environmental and economic benefits make it a desirable alternative. As technology improves, more of the drawbacks will be decreased, and ethanol and other alternative fuels will become mainstream and standard-issue, leading the United States away from our gasoline addiction.

Ocean Energy

Nearly seventy percent of the Earth's surface is covered by oceans, which have the potential to supply humans with an enormous amount of renewable energy. Humans have exploited the vast energy potential of Earth's oceans by taking advantage of wave movement, tides, ocean currents, and ocean thermal energy. The United States, however, has given little or no attention to ocean energy up until this point. This is because of major problems with siting power plants and various economic obstacles. Recent legislation has brightened the future outlook of ocean energy in the United States, but the fledgling technology will take years to realize its potential and account for any significant portion of the United States' consumption of renewable energy. Though the United States does not currently have many power-generating facilities to take advantage of ocean energy, some private and public associations have begun eyeing existing European technologies in hopes of bringing them to American soil or rather, waters. Europe is the world's leader in exploiting ocean energy, due in large part to its location and natural geography. For example, winds blown across the Atlantic from west to east naturally increase the size of waves on Europe's western coast of the west coast of Britain. Larger waves

Renewable Energy

have greater energy, and therefore more power producing ability. Europe has also led the way in technologies that exploit underwater currents and tides. The United States hopes to learn from these technologies, plus the non-European ocean thermal energy conversion (OTEC) technology, which is feasible only in equatorial waters like those around Hawaii. The city of San Francisco has recently collaborated with a Scottish group called Scotland's Ocean Power on a demonstration project for capturing wave energy, which is one of the four major types of ocean energy.⁴⁹ This technology works on the principle of rolling waves flowing through joints in a large cylindrical pipe, which pushes high pressure oil through hydraulic motors to generate electricity- which is in turn fed to an onshore grid through an underwater cable. Plans are underway to create a "wave farm" off the coast of Britain using these wave energy converters. One square kilometer of ocean interspersed with the devices would produce about 30 MW of electricity, which could power 20,000 homes. About twenty square kilometers could power the city of Edinburgh.⁵⁰ The U.S. has similar ambitions in areas of the Pacific Northwest, like Orego , Washington, and southern regions of Alaska. In terms of price, the technology in Europe provides electricity at the equivalent of about 9 cents per kW, which is about twice the price of wind power in Europe.⁵¹ Obviously then, the technology has a way to go before it becomes competitive in Europe, and especially the United States, which is further behind. There are numerous other variations of wave-energy systems besides the one mentioned, falling into the categories of onshore, near-shore, or offshore systems; but in any case, the systems manipulate wave motions to power hydraulic pumps or spin turbines, thus generating electricity which is fed via cable to the nearest electricity grid. Americans see another example of ocean energy technology in France, which is home to the world's largest (240 MW) tidal power plant.⁵² Tidal-power plants such as the one in La Rance, France, operate by damming an estuary and generating electricity from water flowing through turbines. There are a number of variations in terms of exactly how electricity is produced, but one popular method is called ebb generation. At high tide, water flows in through openings in the barrage, or dam, spinning turbines to generate electricity. The water is retained behind the barrage until low tide, when it flows out again, once again spinning the turbines and generating electricity. The predictability of tides makes tidal power a reliable energy source, though it can only produce electricity at certain times of day: during high and low tides. Unfortunately, there are only a handful of places in the world where tidal power generation is efficient, and the United States is not home to many. These places

Renewable Energy

observe a difference of about 5-10 meters between high and low tide, which is ideal and also costs for building these types of projects run high, deterring investors who want quicker returns on their money. Tidal power plants typically have negative impacts on estuarine ecosystems as well, adding a further obstacle to their implementation.

LECTURE – 3

Lecture-3 Renewable Energy- Potentials and Achievements

Importance- Conventional energy Sources – Potential and Achievements in India

Energy is one of the major building blocks of modern society. Energy is needed to create goods from natural resources. Economic development and improved standards of energy are complex processes that share a common denominator: the availability of an adequate and reliable supply of energy. Political events, beginning with an oil embargo in 1973 and continuing through the Iranian revolution of 1979 and the Persian Gulf War of 1991, made many people aware of how crucial energy is to the everyday functioning of our society. Long gasoline lines and cold winters with natural gas shortages in the 1970s are still unhappy memories for some people. The energy crisis of the 1970s was almost forgotten by the 1980s. However, that decade brought an increased awareness of over environment. Concerns about global warming, acid rain and radioactive waste are still very much with us today, and each of these topics is related to our use of energy.

Energy pervades all sectors of society; economics, labour, environment, international relations in addition to our own personal livings i.e., housing, food, transportation, recreation and more. The use of energy resources has relieved us from many drudgeries and made our efforts more productive. Human beings once had to depend on their own muscles to provide the energy necessary to do work. Today our muscles supply less than 1% of the work done in the industrialized world.

Energy might best be described in terms of what it can do. We cannot see energy, only its effects; we cannot make it, only use it; and we cannot destroy it, only waste it through inefficient use. Unlike food and housing, energy is not valued in it but for what can be done with it.

Energy is a basic concept in all the science and engineering discipline. A very important principle is that energy is a conserved quantity, i.e., the total amount of energy in the universe is constant. Energy is not created or destroyed but just converted or redistributed from one form '

to another, such as from wind energy into electrical energy or from chemical energy into heat etc.

Classification of energy on the basis of source

On the basis of source, the energy can be classified as direct and indirect energy.

1. Direct source of energy

The direct sources of energy are those, which release the energy directly-like human labor, bullocks, stationary and mobile mechanical or electric power units, such as diesel engines, electric motor, power tiller and tractors. The direct energy may be further classified as renewable and non-renewable sources of energy depending upon their replenishment.

1.1. Renewable direct sources of energy

In this category, the energy sources, which are direct in nature but can be subsequently replenished, are grouped. The energies, which may fall in this group, are human beings, animals, solar and wind energy, fuel wood, agricultural wastes, etc.

1.2. Non-Renewable direct sources of energy

In this category, direct energy sources that are not renewable (at least in near future say next 100 years) are classified. Coal and fossil fuels exemplify non-renewable direct sources of energy.

2. Indirect sources of energy

The indirect sources of energy are those, which do not release energy directly but release it by conversion process. Some energy is invested in producing indirect sources of energy. Seeds, manures (farm yard and poultry), chemicals, fertilizers and machinery can be classified under indirect sources of energy. Again, on the basis of their replenishment, these can be further classified into renewable and non-renewable indirect source of energy.

2.1. Renewable indirect source of energy

Seed and manure can be termed as renewable indirect source of energy as they can be replenished in due course of time.

2.2. Non-renewable indirect source of energy

The energy sources, which are not replenished, come under non-renewable indirect sources of energy. Chemicals, fertilizers and machinery manufacturing are the non-renewable indirect sources of energy.

Classification of energy on the basis of comparative economic value

On the basis of comparative economic value the energy may be classified as commercial and non-commercial.

1. Non-commercial energy

Each and every energy source has some economic value. Some energy sources are available comparatively at low cost whereas others are capital intensive. The energy sources, which are available cheaply, are called non-commercial sources of energy whereas the ones which are capital intensive are called commercial energy sources.

Human labor and bullocks exemplify the category of non-commercial source of energy. One may argue that the unit energy available from animate sources is costlier than the mechanical energy. Therefore, animal sources of energy should be classified under the non-commercial. However, one should also bear in mind that human labour and animals are readily available and can be used as a sources of power directly, whereas in case of mechanical sources of energy, the machines (tractors, stationary engines, electric motors, etc. are very costly in terms of their purchase price and also often require a skilled operator.

The commonly available and less expensive materials like fuel wood, twigs, leaves agro-wastes and animal dung, etc. are also classified as non-commercial sources of energy.

2. Commercial energy

The energy sources like petroleum products (diesel, petrol and kerosene oil) and electricity, which are capital intensive exemplify / commercial sources of energy. Considering the fact that most of the commercial sources are also non-renewable and to some extent are imported in India, efforts are made to conserve such sources of energy.

Fundamentals Of Renewable/Non Renewable Energy Sources

Definitions

For all practical purposes, energy supplies can be divided into two classes:

“Renewable energy is the energy obtained from regenerative or virtually inexhaustible sources of energy occurring in the natural environment like solar energy, wind energy etc. That type of energy is passing through the environment irrespective of there being a man made device to intercept and harness the power. This is also referred as **non-conventional sources of energy.**”

“Nonrenewable energy is the energy obtained from static stores of energy which remain bound unless released by human interaction. Examples are fossil fuels of coal, oil and natural gas and nuclear fuels. That type of energy is initially in an isolated energy potential and external action is required to initiate the supply of energy for practical purposes. This type of energy is also sometimes called finite energy or **conventional sources of energy.** “

These two definitions are portrayed in Figure 1. Table .3 provides a comparison between renewable and nonrenewable energy system.

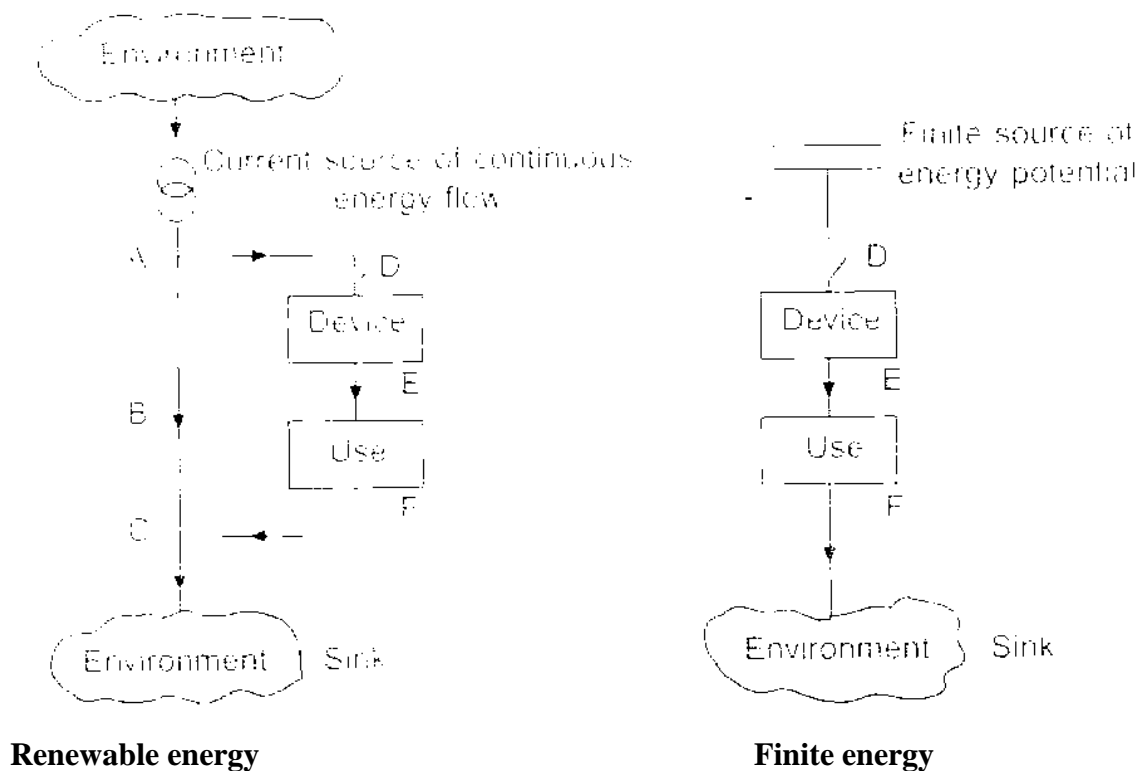

Figure. 1. Contrast between renewable and finite energy supplies

Energy Sources

1. There are six ultimate sources of useful energy:
2. The Sun;
3. The motion and gravitational potential of the sun, moon and earth;
4. Geothermal energy from cooling, chemical reactions and the radioactive decay inside the earth;
5. Nuclear reactions on the earth;
6. Chemical reactions from mineral sources; and
7. Fossil fuel (Petroleum product and gases).

Table .1 Comparison of renewable and nonrenewable energy systems

<i>Features of comparison</i>	<i>Renewable energy supplies</i>	<i>Nonrenewable energy supplies</i>
Examples	Wind, solar, biomass, tidal etc.	Coal, oil, gas etc.
Source	Natural local environment	Concentrated stock
Normal state	A current of energy	Static store of energy
Life time of supply	Infinite	Finite
Cost at source	Free	Increasingly expensive
Location for use	Site and society specific	General and international use
Scale	Small scale, economic, large scale may present difficulties	Increased scale often improves supply costs, large scale frequently favored
Skills	Interdisciplinary and varied wide range of skills	Strong links with electrical and mechanical engineering. Narrow range of skill
Context	Rural, decentralized industry	Urban, centralized industry
Dependence	Self-sufficient system encouraged	Systems dependent on outside inputs
Pollution and environmental damage	Usually little environmental harm, especially at moderate scale. Hazards from excessive wood burning, soil erosion from excessive biofuel use, large hydro reservoirs disruptive	Environmental pollution common, and especially of air and water Deforestation and ecological sterilization from excessive air pollution
Safety	Local hazards possible in operation, usually safe when out of action	May be shielded and enclosed to lessen great potential danger

Renewable Energy

Renewable energy is derived from sources 1, 2 and 3. Finite energy namely non renewable (conventional energy) is derived from sources 4, 5 and 6.

Renewable Energy Sources

The continuing depletion of fossil fuels and the environmental hazards posed by the needs of future development are gradually shifting the path of development towards sustainability, better sociability and environmental responsibility which in turn emphasizes the need for renewable energy sources. The area of renewable energy sources is expanding rapidly and numerous innovations as well as applications are taking place. The decentralized renewable energy systems concept has been recognized as an answer to meeting the energy demands both in the household and in the agro-industrial sector. The exhaustion of natural resources and the accelerated demand of conventional energy have forced planners and policy makers to look for alternate sources.

Presently, even though commercial energy sources like coal, oil, natural gas are being utilized to a large extent, renewable sources of energy are slowly gaining importance. Renewable energy plays a basic ingredient for sustainable development. Such sources can supply the energy we need for indefinite periods of time polluting far less than fossil fuels. The advantages of renewables are well known, as far as they enhance diversity in energy supply markets; secure long-term sustainable energy supplies; reduce local and global atmospheric emissions; create new employment opportunities offering possibilities for local manufacturing.

Energy Scenario In India

Energy-use Statistics

Currently, India is the sixth largest energy consumer in the world and the country's energy consumption is expected to increase in the near future. In the past, India has derived most of its energy from coal, but recently the country has been making efforts to extract energy from other sources. However, fossil fuels still remain the largest energy source. About 76% of India's electricity is produced in power plants using coal or petroleum products (Buran et al., 2003).

Of the remainder, 22% is hydroelectric and 2% is nuclear. According to data from India's Ministry of Statistics and Programme Implementation, the nation's total energy

consumption has increased approximately fourfold over the last three decades. In 1999, India had an electricity consumption total of approximately 4.24×10^{11} KWh (Anon, 2001).

India is the world's third largest coal producer, ranking behind only the United States and China. Current domestic production of coal meets approximately 95% of domestic demand. Coal consumption is expected to increase by 28% by 2010 and is expected to remain the primary source of fuel despite increased reliance on natural gas (Lynch, 2001). Oil provides roughly 30% of India's energy, but domestic production of oil provides for only a third of India's oil demand. By 2010, roughly 75% of India's oil and gas need will be met by imports (Lynch, 2001). The government predicts that, with present consumption and production trends, India will deplete its oil reserves by 2012. The Indian government is now encouraging exploration for oil to reduce its dependence on imports. However, many researchers believe that India's easy-access reserves have already been tapped.

There are numerous projections for India's energy consumption in the coming years and all agree that the increase will not simply be linear. One estimate projects an 8-10% annual increase in energy demand over the next 15 years if the economy continues to grow at the expected rate of 7-8% per year (Buran et. al., 2003).

Pollution Statistics

India emits the fifth most carbon of any country in the world: at 253 million metric tons, only the United States, China, Russia and Japan surpassed its 1998 level of carbon emissions. The carbon emissions have grown ninefold over the past 40 years and are forecasted to grow 3.2% per year until 2020, and are faster than both China and the United States.

The Indian Government estimates the cost of environmental degradation in recent years to be 4.5% of GDP.

Low energy-efficiency of coal-burning power plant is a contributing factor. India's coal plants are old and are not equipped with the most modern pollution controls. With the shortage of generating capacity and scarcity of public funds, old coal-fired plants will likely remain in operation for sometime. Power plant modernization, improvements in transmission to cut distribution losses and legislation to encourage end-user energy conservation are all part of the Government's current energy efficiency efforts.

Emerging industrial centers and the lack of pollution-control mechanisms have resulted in a severe drop in air quality in India. Of the 3 million premature deaths in the world that occur

annually due to air pollution, more than 5,00,000 occur in India (Anon, 2000). According to the World Health Organization, the city of New Delhi is one of the ten most polluted cities in the world (Michaels, 2001).

Nuclear Energy

India has 14 nuclear reactors operating with 2720 MWe combined generating capacity. Four 220 MWe reactors were commissioned between late 1999 and December 2000. The Nuclear Power Corporation of India Limited (NPCIL) wants to boost capacity to 20,000 MWe by 2020 (7 -10% of total electricity generating capacity). The outlook is improving for India's nuclear-power industry, as plants have been running at an average capacity factor of 80% and reactor outages have been shortened. Quality of fuel supplies has risen and delivery times have improved. In 1999, NPCIL declared its first dividend, but nuclear industry is still heavily reliant on Government funding. Government spending for research and development for the current five-year plan is \$193.5 million which is five times the previous level. By mid-2001, two more reactors were scheduled to enter critical development stages. Construction is progressing on two 500 MWe units: the first uses Indian-developed design and technology. Construction is also scheduled for six additional reactors.

Alternative Energy Projections

By 2010, India wants 10% of all additional electric capacity to come from renewable energy sources. The Indian Renewable Energy Development Agency (commonly known as IREDA), which is a part of the Ministry of Non-Conventional Energy Sources, oversees the development of these energy sources.

Renewable Energy Potential In India

Renewable Energy Programme

The relevance of the increasing use of renewable energy sources in the transition to a sustainable energy base was recognised in India even in the early 1970s. Since the early 1980s, a significant thrust has been given to the development, trial and induction of a variety of renewable energy technologies for use in different sectors. To begin with, the endeavours were steered and overseen by the Commission for Additional Sources of Energy (CASE) set up in 1981. In 1982, a separate Department of Non-Conventional Energy Sources (DNES) was

Renewable Energy

created in the Ministry of Energy and was entrusted with the charge of promoting non-conventional energy sources. A decade later, this was upgraded and thus MNES (Ministry of Non-Conventional Energy Sources) started functioning as a separate Ministry from 1992 to develop all areas of renewable energy.

As per its mandate, the MNES has been implementing a broad-based programme covering the whole spectrum of renewable energy technologies. The aim of the programme is to (a) increase the share of renewables in the overall installed capacity power generation (b) meet the energy needs of rural and remote areas for a variety of applications (c) minimize the drudgery and health hazards faced by rural women in following the age-old practice of cooking with fuel-wood collected from long distances and in traditional chulhas which emit a lot of smoke and (d) extract energy from urban and industrial waste besides chemical, ocean and geothermal sources. The underlying idea of the programme is not to substitute but to supplement the conventional energy generation in meeting the basic energy needs of the community at large.

Current Status

The national programmes in different areas of renewable energy sector have resulted not only in generation of public awareness about the advantages of renewable energy but also in a visible increase in the deployment of renewable energy systems and devices for varied applications. Consequently, the contribution of renewable energy to total installed capacity of power generation has been progressively rising. As on October, 2003, the contribution of renewables has reached 4132 MW, representing about 4% of total grid capacity, as compared to 2414 MW on October 1999. Almost all the areas namely solar, wind, biomass, small hydro and urban as well as industrial waste have contributed to the satisfactory achievement of renewable energy sources in the country. With a wind power capacity of 2000 MW, India now ranks fifth in the world. Small hydropower generation, which is particularly suitable for remote and hilly regions, is being expanded. India is the largest producer of cane sugar and the world's largest bagasse based co-generation programme is being implemented in the sugar mills. There is also considerable scope for extracting energy from urban and industrial wastes.

The programmes to meet the rural energy needs are the National Project on Biogas Development (NPBD) and the National Programme on Improved Chulhas (NPIC). The NPBD aims at harnessing the fuel value of the cattle dung, human waste and non-woody organic wastes

Renewable Energy

without losing their manurial value and minimising the drudgery of rural woman in walking long distances to collect fuel wood. The objective of NPIC is to improve efficiency of biomass fuels without indoor air pollution.

Rapid urbanisation and industrialisation have led to generation of huge quantities of wastes, which are rich sources of energy. Under the National Programme on Energy Recovery from urban, municipal and industrial wastes, promotion and development of projects leased on appropriate conversion technologies such as biomethanation, gasification, palletisation and land fills is being undertaken. This programme aims at harenessing the estimated power generation potential of about 1000 MW from urban and municipal wastes and about 700 MW from industrial wastes. Projects with an aggregate capacity of 26 MWe have been completed. The achievements of various renewable energy sources in India during the last four years has been shown in Table2.

Table.2 Renewable energy achievements in India during the last four years

SI. No	Programmes	As on 12.10.1999	As on 12.10.2003
A.	Grid Connected Systems (installed capacity in MW)		
	Wind power	1022.00	2002.00
	Small Hydro	1218.00	1530.00
	power Biomass/Cogeneration power	171.00	571.00
	Urban and industrial waste power	2.00	26.00
	Solar photovoltaic power	1.00	3.00
	Total	2414.00	4132.00
B.	Decentralized systems		
	Biogas plants (Nos. in lakh)	28.80	35.50
	biogas plants (Nos.)	2, 673.00	3. 902.00
	Improved chulha (Nos. in lakh)	250.00	350.00
	Solar home lighting systems(No)	64,000.00	2,60,00000
	Solar street lighting sys. (Nos.)	32,920.00	43,470.00
	Solar lanterns (Nos. in lakh)	2.22	4.42
	SPV pumps (Nos.) (solar pv)	2, 160.00	6, 400.00
	Solar water heating system (lake sq. meter collector area)	5.70	7.00

Source: <http://mnes.nic.in> [Ministry of Non-Conventional energy sources. New Delhi, India]

Besides sun, wind, biomass, small hydro and urban and industrial wastes, there are other sources of renewable energy, which are mostly in the stage of R & D. These include fuel cell, hydrogen energy, geothermal and ocean energy. Significant progress has been recorded during the year in areas of fuel cell technology, hydrogen energy, battery-powered vehicles and tapping geo-thermal energy under the Ministry's programme on new technologies. Installation of a demonstration geothermal power plant of 300 kW capacity at tattapani in Chhatisgarh state is being taken up through National hydro Power Corporation, India. A detailed project report for a 3 MW tidal powerplant in Sunderbans area of West Bengal has been prepared through West Bengal Renewable Energy Development Agency.

Importance of Renewable Energy Resources and Technologies for Sustainable Development

The exploitation of renewable energy resources and technologies is a key component of sustainable development (Anon, 1995). There are three significant reasons for it as follows:

They have much less environmental impact compared to other sources of energy since there are no any energy sources with zero environmental impact. There are a variety of choices available in practice that shift to renewables for providing a far cleaner energy system than would be feasible by tightening controls on conventional energy.

Renewable energy sources cannot be depleted unlike fossil fuel and uranium resources. If used wisely in appropriate and efficient applications, they can provide a reliable and sustainable supply energy almost indefinitely. In contrast, fossil fuel and nuclear energy sources are finite and can be diminished by extraction and consumption,

They favour power system decentralization and locally applicable solutions more or less: independent of the national network, thus enhancing the flexibility of the system and the economic power supply to small isolated settlements. That is why, many different renewable energy technologies are potentially available for use in urban areas.

Essential Factors for Sustainable Developments

The main concept of sustainability, which often inspires local and national authorities to incorporate environmental considerations in setting energy programme, though being given many different meanings in different contexts, embodies a long-term perspectives. Besides, the future energy system will be largely shaped by broad and powerful trends that have their roots in basic human needs. In conjunction with this, the increasing world population requires the

Renewable Energy

definition and successful implementation of sustainable development. There are various essential parameters that can help in achieving a successful sustainable development in a society. Such parameters can be described as follows:

Public awareness: This is the initial step and very crucial in making the sustainable energy programme successful. This should be carried out through the media and by public and/or professional organization.

Information: Necessary informational input on energy utilization, environmental impacts, renewable energy resources etc. should be provided to public through public and government channels

Environmental education and training: This can be implemented as a completing part of the information. Any approach which does not have an integral education and training is likely to fail. That is why, this can be considered as the significant prerequisite for a ' sustainable energy program. For this reason, a wide scope of specialized agencies and training facilities should be made available to the public.

Innovative energy strategies: These should be provided for an effective sustainable energy program and therefore require the efficient dissemination of information, based on new methods and consisting of public relations, training and counseling

Promoting renewable energy resources: In order to achieve environmentally benign sustainable energy programs, renewable energy sources should be promoted in every stage. This will create a strong basis for the short and long term policies.

Financing: This is a very important tool that can be used for reaching the main goal and will accelerate the implementation of renewable energy systems and technologies for sustainable energy development of the country. Some countries, e.g., Germany, apply the support a different way and simply exempt the people who use such systems and technologies from some portion of their taxes.

Monitoring and evaluation tools: In order to see how successfully, the program has been implemented, it is of great importance to monitor each step and evaluate the data and findings obtained. In this regard, appropriate monitoring and evaluation tools should be used.

Lecture-4 Characterization of biomass

The characterization of the conversion processes of lignocellulosic biomass to biofuels requires a large array of methods and analytical systems to extract the meaningful parameters necessary to describe the solid materials and the conversion liquors. The crucial point is also to develop robust, reliable and high-throughput methods that allow the analysis of large number of samples of various sizes (from mg to kg) and of high heterogeneity. The Walker lab has been developing new and cutting-edge methods ranging from single molecule analysis, microplate assays for the studies of cellulose's and cellulose cocktails, and non-destructive vibrational spectroscopy methods for biomass and bioprocesses analysis, among others. The Biofuel Research Laboratory has been equipped with analytical systems that meet these needs and expand the analytical capabilities for our group and the broader community involve in biofuel R&D. These systems include HPLCs for fluorescence, UV-VIS and Refractive Index (RI) detection, Liquid Chromatography coupled with a Mass Spectrometer (LC-MS) for metabolites characterization and quantification, UV-Vis and fluorescence plate readers, Fourier Transform Infrared and Near-Infrared spectrometers, gas chromatograph, UV-Vis spectrometers, automated protein purification system (FPLC). Some of these methods and instrumentation are described below.

Detailed and accurate characterization of biomass feedstock, intermediates, and products is a necessity for any biomass-to-biofuels conversion. Understanding how the individual biomass components and reaction products interact at each stage in the process is important for researchers.

With a large inventory of standard biomass samples as reference materials, NREL maintains a biomass feedstock composition and property database with the chemical, thermal, and mechanical properties of various biomass feedstock materials.

NREL's biomass characterization capabilities include:

Developing standard laboratory analytical procedures NREL wrote most of the standard biomass laboratory analytical procedures for characterization that are used throughout

the research community. At NREL, we develop new methods and tools to understand more about chemical composition of raw biomass feedstock and the solid, liquid, and slurry samples produced during conversion.

Performing real-time biomass analysis NREL combines multivariate analysis with near-infrared spectroscopy to provide real-time biomass analysis. Using this rapid analysis technique, researchers can analyze a wide range of physical and chemical characteristics of raw and processed biomass within minutes instead of days.

Investigating structural changes Researchers investigate structural changes in biomass from the plant tissue to the macromolecular scale using established and advanced imaging tools in the Biomass Surface Characterization Laboratory. NREL has developed methods to visualize the deconstruction of plant cell walls during biomass conversion. This provides an understanding, for example, of the behavior of lignin during the pretreatment process or of the interactions between enzymes and the biomass cell wall.

With such a wide range of biomass sources and production process variables, understanding the chemical composition of the material becomes an important issue.

Typical biomass components

(a) Cellulose

A polysaccharide in which D-glucose is linked uniformly by β -glucosidic bonds. Its molecular formula is $(C_6H_{12}O_6)_n$. The degree of polymerization, indicated by n , is broad, ranging from several thousand to several tens of thousands. Total hydrolysis of cellulose yields D-glucose (a monosaccharide), but partial hydrolysis yields a disaccharide (cellobiose) and polysaccharides in which n is in the order of 3 to 10. Cellulose has a crystalline structure and great resistance to acids and alkalis.

(b) Hemicellulose

A polysaccharide whose units are 5-carbon monosaccharides including D-xylose and D-arabinose, and 6-carbon monosaccharides including D-mannose, D-galactose, and D-glucose. The 5-carbon monosaccharides outnumber the 6-carbon monosaccharides, and the average molecular formula is $(C_5H_8O_4)_n$. Because the degree of polymerization

n is 50 to 200, which is smaller than that of cellulose, it breaks down more easily than cellulose, and many hemicelluloses are soluble in alkaline solutions. A common hemicellulose is xylan, which consists of xylose with 1,4 bonds. Figure 2.3.1-c shows the structural formula of xylan. Other hemicelluloses include glucomannan, but all hemicelluloses vary in amounts depending on tree species and the part of the plant.

(c) Lignin

A compound whose constituent units, phenylpropane and its derivatives, are bonded 3-dimensionally. Its structure is complex and not yet fully understood. Figure 2.3.1-d shows a constituent unit. Its complex 3-dimensional structure is decomposed with difficulty by microorganisms and chemicals, and its function is therefore thought to be conferring mechanical strength and protection. Cellulose, hemicellulose, and lignin are universally found in many kinds of biomass, and are the most plentiful natural carbon resources on Earth.

(d) Starch

Like cellulose, starch is a polysaccharide whose constituent units are D-glucose, but they are linked by α -glycosidic bonds. Owing to the difference in the bond structures, cellulose is not water-soluble, while part of starch is soluble in hot water (amylose, with a molecular weight of about 10,000 to 50,000, accounting for 10%–20% of starch) and part is not soluble (amylopectin, with a molecular weight of about 50,000 to 100,000, accounting for 80%–90% of starch). Starch is found in seeds, tubers (roots), and stems, and has a very high value as food.

(e) Proteins

These are macromolecular compounds in which amino acids are polymerized to a high degree. Properties differ depending on the kinds and ratios of constituent amino acids, and the degree of polymerization. Proteins are not a primary component of biomass, and account for a lower proportion than do the previous three components.

(f) Other components (organic and inorganic)

The amounts of the other organic components vary widely depending on specie, but there are also organic components with high value, such as glycerides (representative examples include rapeseed oil, palm oil, and other vegetable oils) and sucrose in sugarcane and sugar beet. Other examples are alkaloids, pigments, terpenes, and

waxes. Although these are found in small amounts, they have very high added value as pharmaceutical ingredients. Biomass comprises organic macromolecular compounds, but it also contains inorganic substances (ash) in trace amounts. The primary metal elements include Ca, K, P, Mg, Si, Al, Fe, and Na. Substances and their amounts differ according to the feedstock type.

Several of the industry standard tests for characterizing biomass are described below:

Total Solids

A way to determine the moisture content within the sample.

Ash Determination

The amount of inorganic or mineral material present in the sample.

Exhaustive Ethanol and Water Extractable:

The removal of non-structural material from the biomass sample to prevent interferences during other analyses, as well as free sugar determination.

Structural Carbohydrates:

The determination of glucose, xylose, galactose, arabinose and mannose concentrations in the sample; used to determine cellulose and hemicellulose concentrations in the biomass.

Acetyl Content:

Acetic acid concentration in the sample, may also include formic and levulinic acid content depending on the feedstock.

Lignin:

Determination of the structural plant material that does not contribute to the sugar content in the sample.

Starch Content:

Represents the readily available source of sugar within some feedstock.

Ethanol Content:

Analysis of fermentation broths using gas chromatography.

Bomb Calorimetry:

The determination of the sample's calorific value.

Using FT-MIR, fundamental vibrations of complex organic samples can be analyzed and sample specific fingerprints can be obtained. FT-MIR exploits the mid-infrared region (4,000 - 400 wavenumber, cm^{-1}). A wide range of samples can be analyzed, categorized and quantified by FT-MIR, ranging from microbes to proteins and biomass. Applied to ligno-cellulosic biomass conversion for sugar production, the prominent peaks within the spectra are at 1033, 1059, 1112, and 1163 cm^{-1} where 1033 and 1059 cm^{-1} correspond to C-O stretching vibration, 1112 cm^{-1} corresponds to asymmetric glucose ring stretch, and 1163 cm^{-1} corresponds to C-O-C asymmetric vibrations within cellulose. Another important peak pertinent to enzymatic hydrolysis of cellulose is the peak at 897 cm^{-1} corresponding to beta-glucosidic bonds of amorphous cellulose. Therefore a direct analysis of conversion efficiency can be performed using FT-IR. The most advanced FT-MIR can be coupled with automated platforms for high throughput analysis in a 96-well microplate format.

Fourier Transform Near Infrared spectrometer (FT-NIR)

Chemometric models associated with Near Infrared (NIR) spectral analysis lend themselves handily to the high throughput, off-line or on-line, monitoring and process control industry, where fast and inexpensive systems are needed to test, predict and make decisions about product quality, or real-time adjustments with online process monitoring. These methods have been developed for agricultural and industrial applications mainly to assess the quality of feeds. FT-NIR is based on the quantification of the vibration overtone intensities in the near-infrared region (12,000-4,000 wavenumber, cm^{-1}). Fourier Transform Near Infrared spectroscopy (FT-NIR) and multivariate modeling are the core of new analytical methods that can be applied for the high-throughput, fast, online or offline analysis of biomass throughout the logistics of the harvest, storage, conversion and assessing chemical composition of biomass. Indeed, the new generations of FT-NIR spectrometers have gained in improved accuracy and reliability compared to diffusive NIR spectrometers (NIRS). The most recent advances

include the use of high quality optic fibers and process-resistant optic probes for the online and real-time monitoring of chemical and biochemical processes. The construction of robust chemometric models associated with the speed and accuracy of FT-NIR spectrometers (FT-NIRS) is used for compositional analysis of feedstock, and analytical monitoring of conversion of feedstocks to the final products, to ultimately develop quality analysis (QA) of the feedstocks and quality control (QC) of the conversion processes.

Fast Protein Liquid Chromatography (FPLC)

Fluorescently tagging functional molecules such as enzymes is key to develop single molecule applications and fluorescence based assays for example. However, it is not trivial as enzyme functions and activities rely upon their conformation, charges, hydrophobicity, all of which can be hindered by the addition of the signaling molecules. Applied to the study of any enzymes, fluorescent labeling has to ensure that the catalytic activity remain unchanged. We have developed an analytical and preparative method based on FPLC purification for the production of enzymes for which we can assess and sort by their degree of labeling and their catalytic activities ensuring optimal fluorescence and activities compared to the native ones. This polishing purification method allows reaching defined and homogenous biochemical reagents.

High performance Liquid Chromatography (HPLC)

An important aspect for the conversion of lignocellulosic biomass to biofuels is the saccharification step which consists in using enzymes to convert the cellulose polymer into sugars. Characterizing and quantifying these sugars is necessary as they will be later fermented into ethanol or other biofuels. HPLC systems based on appropriate separation columns are used to measure these sugars and to measure the specific activities of enzymes, engineered enzymes and cocktails of these. Other methods have been implemented by the Walker lab to measure other compounds and metabolites from lignocellulosic biomass pretreatment and fermentation such as organic acids and alcohols during anaerobic fermentation for hydrogen production.

Lecture 5

Biomass Briquetting – A Value Adding Technology for Agro Residues

Introduction

Biomass plays a major part in fulfilling the energy needs of the developing countries. According to the world's energy topics, it is widely accepted that fossil fuel shortage, fuel increasing price, global warming including other environmental problems are critical issues. Therefore, biomass energy has been attracting attention as an energy source since zero net carbon dioxide accumulation in the atmosphere from biomass production and utilization can be achieved. The carbon dioxide released during combustion process is compensated by the carbon dioxide consumption in photosynthesis. Among several kinds of biomass, agro residues have become one of most promising choices. They are available as a free or almost free, indigenous and abundant energy source. But it is generally difficult to handle them because of its bulky nature, low combustion characteristics and copious liberation of smoke. The direct burning of these agro residues in domestic and industrial applications is inefficient and associated with wide scale air pollution. In order to achieve more efficient usage of agro residues, it is essential to densify them to compact pieces of definite shape and high thermal value. Briquetting is one of the several compaction technologies in the category of densification. The process of briquetting consists of applying pressure to a mass of particles with or without a binder and converting it into a compact product of high bulk density, low moisture content, uniform size and shape and good burning characteristics. Briquettes can be produced with the density of 1.2 to 1.4 g/cm³ from loose agro residues with a bulk density of 0.1 to 0.2 g/cm³.

Raw materials for briquetting

Almost all agro residues can be briquetted. Agro residues such as saw dust, rice husk, tapioca waste, groundnut shell, cotton stalks, pigeon pea stalks, soybean stalks, coir pith, mustard stalks, sugar cane bagasse, wood chips, tamarind pod, castor husk, coffee husk, dried tapioca stick, coconut shell powder are the commonly used raw materials for briquetting in India. All these residues can be briquetted individually and in combination with or without

Renewable Energy

using binders. The factors that mainly influence on the selection of raw materials are moisture content, ash content, flow characteristics, flow characteristics, particle size and availability in the locality. Moisture content in the range of 10-15% is preferred because high moisture content will pose problems in grinding and more energy is required for drying. The ash content of biomass affects its slagging behaviour together with the operating conditions and mineral composition of ash. Biomass feedstock having up to 4% of ash content is preferred for briquetting. The granular homogeneous materials which can flow easily in conveyers, bunkers and storage silos are suitable for briquetting.

Briquetting Process

The series of steps involved in the briquetting process are

1. Collection of raw materials
2. Preparation of raw materials
3. Compaction
4. Cooling and Storage.

Collection of raw materials

In general, any material that will burn, but is not in a convenient shape, size or form to be readily usable as fuel is a good candidate for briquetting.



Preparation of raw materials

The preparation of raw materials includes drying, size reduction, mixing of raw materials in correct proportion, mixing of raw materials with binder etc.

Drying

The raw materials are available in higher moisture contents than what required for briquetting. Drying can be done in open air (sun), in solar driers, with a heater or with hot air.



Size reduction

The raw material is first reduced in size by shredding, chopping, crushing, breaking, rolling, hammering, milling, grinding, cutting etc. until it reaches a suitably small and uniform size (1 to 10 mm). For some materials which are available in the size range of 1 to 10mm need not be size reduced. Since the size reduction process consumes a good deal of energy, this should be as short as possible.



Shredding machine

Raw material mixing

It is desirable to make briquettes of more than one raw material. Mixing will be done in proper proportion in such a way that the product should have good compaction and high calorific value.

Compaction

Compaction process takes place inside the briquetting machine. The process depends on the briquetting technology adopted.

Briquetting Technologies

Briquetting technologies used in the briquetting of the agro residues are divided into three categories. They are (i) high pressure or high compaction technology, (ii) Medium pressure technology and (iii) low pressure technology. In high pressure briquetting machines, the pressure reaches the value of 100 MPa. This type is suitable for the residues of high lignin content. At this high pressure the temperature rises to about 200 - 250° C, which is sufficient to fuse the lignin content of the residue, which acts as a binder and so, no need of any additional binding material. In medium pressure type of machines, the pressure developed will be in the range of 5 MPa and 100MPa which results in lower heat generation. This type of machines requires additional heating to melt the lignin content of the agro residues which eliminates the use of an additional binder material. The third type of machine called the low pressure machines works at a pressure less than 5 MPa and room temperature. This type of machines requires addition of binding materials. This type of machines is applicable for the carbonized materials due to the lack of the lignin material.

The high pressure compaction technology for briquetting of agro residues can be differentiated in to two types (i) hydraulic piston press type and (ii) screw press type. Among these two technologies hydraulic piston press type was predominantly used to produce briquettes in India, particularly in TamilNadu all the briquette producing firms' uses hydraulic piston press technology for briquetting. Mostly cylindrical shaped briquettes with 30 mm to 90 mm diameter were produced. All the commercial firms involved in briquette making produces 60 mm and 90 mm diameter briquettes.

Cooling and Storage of briquettes

Briquettes extruding out of the machines are hot with temperatures exceeding 100°C. They have to be cooled and stored in dry place.



Uses for Briquettes

The most frequent applications for this type of fuel are of both a domestic and industrial nature; from fireplaces or stoves to boilers generating hot water and steam. Tea industries, wine distilleries, textile industries, and farms are the major sectors using briquettes. Briquettes are also used in gasification process for electricity production.

Advantages of agro residual briquettes:

- ✓ The process increase the net calorific value of material per unit volume
- ✓ End product is easy to transport and store
- ✓ The fuel produced is uniform in size and quality
- ✓ Helps solve the problem of residue disposal
- ✓ Helps to reduce deforestation by providing a substitute for fuel wood.
- ✓ The process reduce/eliminates the possibility of spontaneous combustion waste
- ✓ The process reduces biodegradation of residues

Necessary requirements to start a briquette production unit

1. Land requirement:

Land area of minimum 1 acre is required for starting a briquette production unit to store the raw materials for briquetting and produced briquettes.

2. Raw materials:

Continuous availability of raw materials is a major factor for profitable briquette production.

3. Drying facility to dry raw materials:

The raw materials which are commonly available are with higher moisture content. So, any of the drying technologies such as solar driers/ heater/ hot air generator system is required to bring down the moisture content to an desirable level for briquetting.

4. Shredding machine:

A shredding machine with minimum of 5 hp motor is required to powder the agro residues for briquetting.

5. Briquetting machine:

A high pressure hydraulic piston press type briquetting machine powered by minimum of 50 hp motor is required to produce binderless briquettes from agro residues.

Lecture-6

Biomass Combustion Technology

Combustion

Biomass combustion is a complex process that consists of consecutive heterogeneous and homogeneous reactions. The main process steps are drying, devolatilization, gasification, char combustion, and gas-phase oxidation. The time used for each reaction depends on the fuel size and properties, on temperature, and on combustion conditions. Batch combustion of a small particle shows a distinct separation between a volatile and a char combustion phase with time. For the design of combustion appliances, the high content of volatiles (80% to 85%) needs to be respected. For large particles, the phases overlap to a certain extent. Nevertheless, even for log wood furnaces, a certain separation of distinct combustion regimes with time can be found. Since automatic combustion systems are operated continuously, the consecutive reactions occur simultaneously at different places in the furnace (e.g., in different sections on and above a grate). Hence the zones for different process steps during combustion can be optimized by furnace design.

A distinct separation of different process steps can be advantageous with respect to pollutant formation. The main combustion parameter is the excess air ratio (\hat{i}) that describes the ratio between the locally available and the stoichiometric amount of combustion air. For typical biomass, the combustion reaction can then be described by the following equation if fuel constituents such as N, K, Cl, etc., are neglected:

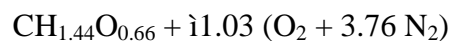

f intermediates (C, CO, H₂, CO₂, C_mH_n, etc.)

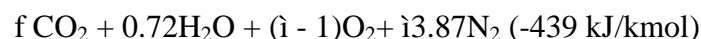

Where, CH_{1.44}O_{0.66} describes the average composition of typical biomass used for combustion, i.e., wood, straw, or similar material. As a result of the combustion process, different types of pollutants can be distinguished:

1. Unburnt pollutants such as CO, C_xH_y, PAH, tar, soot, unburnt carbon, H₂, HCN, NH₃, and N₂O;
2. Pollutants from complete combustion such as NO_x (NO and NO₂), CO₂, and H₂O; and
3. Ash and contaminants such as ash particles (KCl, etc.), SO₂, HCl, PCDD/F, Cu, Pb, Zn, Cd, etc.

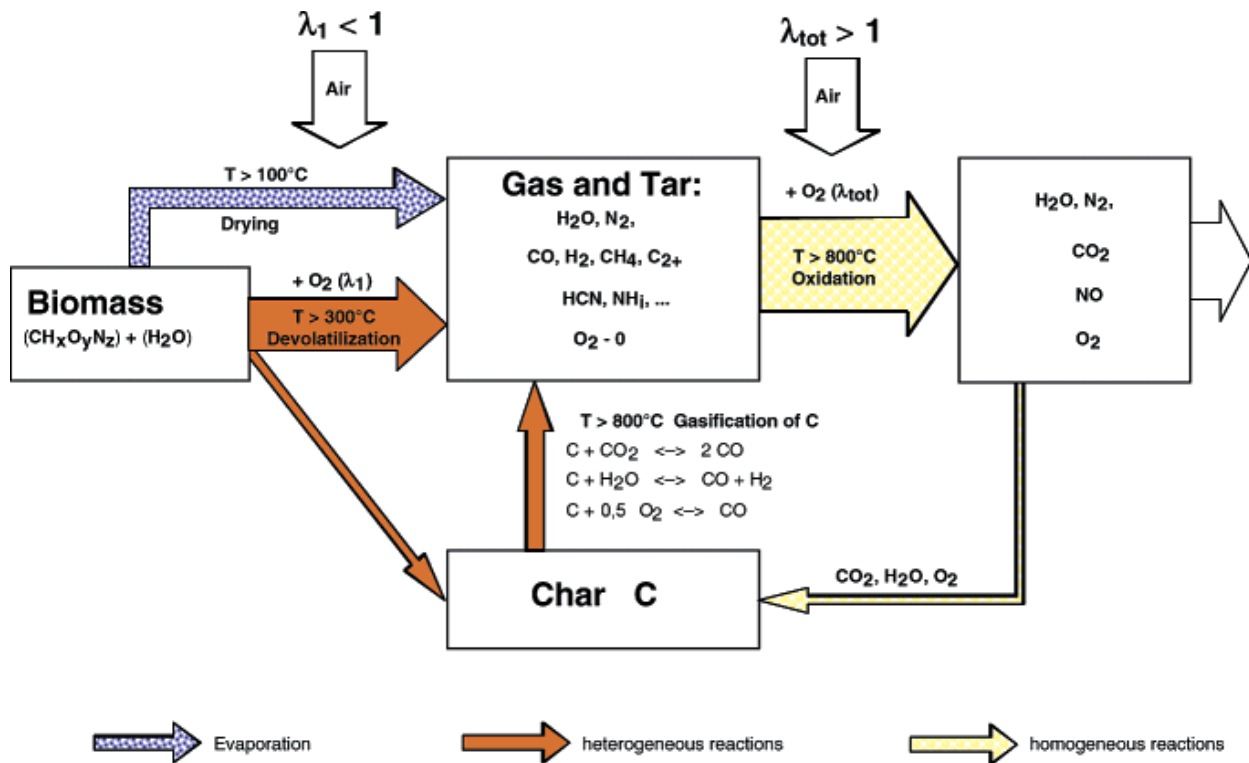

Staged Combustion

If staged combustion is applied, the excess air can vary in different sections. Two-stage combustion is applied with primary air injection in the fuel bed and consecutive secondary air injection in the combustion chamber. This enables good mixing of combustion air with the combustible gases formed by devolatilization and gasification in the fuel bed. If good mixing is ascertained, an operation at low excess air is possible (i.e., excess air $\lambda < 1.5$) thus enabling high efficiency on one hand and high temperature with complete burnout on the other hand. If good mixing is achieved, the concentrations of unburnt pollutants can be reduced to levels close to zero (e.g., CO < 50 mg/m³ and C_xH_y < 5 mg/m³ at 11 vol % O₂). However, an accurate process control is needed to ensure optimum excess air in practice. For this purpose, self-adjusting control systems with use of sensors for CO and λ (CO/ λ -controller) or of CO and temperature have been developed. Air staging applies air injection at two levels as well. In addition to conventional two-stage combustion, primary air needs to be understoichiometric (λ primary < 1). Further, a relevant residence time (and hence a reduction zone in the furnace thus leading to an enlarged furnace volume) is needed between the fuel bed and the secondary air inlet. In fuel staging, fuel is fed into the furnace at two different levels. The primary fuel is combusted with excess air > 1. A consecutive reduction zone is achieved by feeding secondary fuel and late inlet of final combustion air for the secondary fuel. Both air staging and fuel staging have been

developed as primary measures for in-situ reduction of fuel NO_x in biomass combustion and are described below.

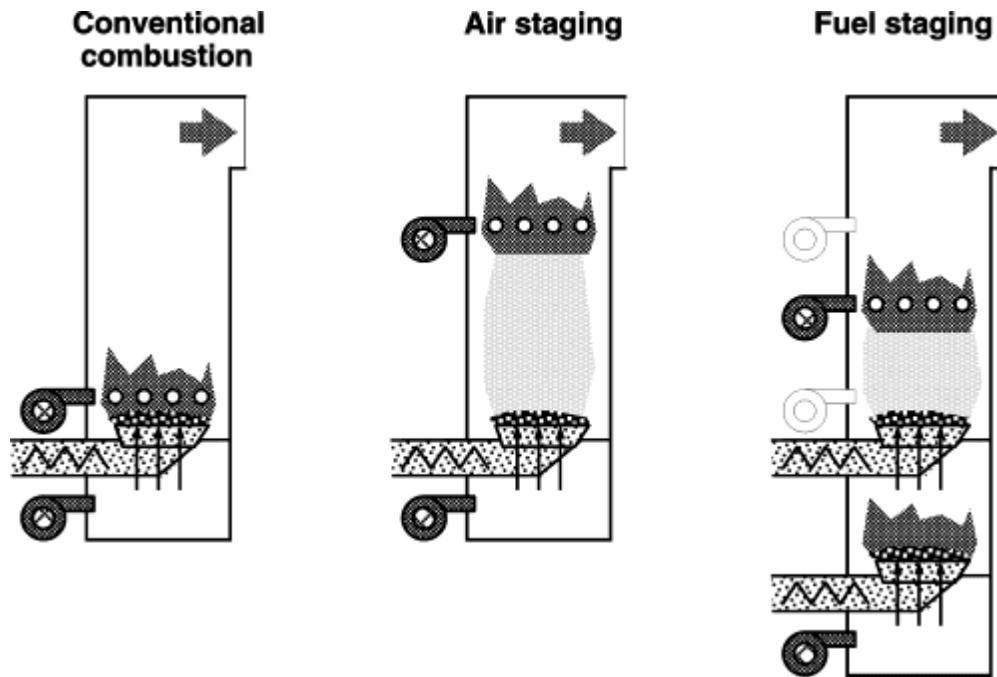

Figure. Principle of conventional two-stage combustion, air staging with reduction zone, and fuel staging with reduction zone.¹⁰

Unburnt Pollutants

The main needs for complete burnout are temperature, time, and turbulence (TTT). The mixing between combustible gases and air can be identified as the factor that is mostly limiting the burnout quality, while the demands for temperature (around 850 °C) and residence time (around 0.5 s) can easily be achieved. Sufficient mixing quality can be achieved in fixed bed combustion by the above-described two-stage combustion. In fluidized bed, good mixing is achieved in the bed and the freeboard and also dust combustion enables good mixing. For future improvements in furnace design, computational fluid dynamics (CFD) can be applied as a standard tool to calculate flow distributions in furnaces, as shown by an example. Furthermore, the reaction chemistry in the gas phase can be implemented in CFD codes.^{14,15} However, the heterogeneous reactions during drying, transport, devolatilization, and gasification of solid biomass before entering the gas phase combustion need to be considered as well and needs further improvement to enable the application of whole furnace modeling. NO_x Emissions. In combustion processes, NO and NO₂ (summarized as NO_x) can be formed in three different reactions. Thermal NO_x and prompt NO_x are formed from nitrogen in the air at high temperatures and in the case of prompt NO_x in the presence of hydrocarbons. Further, fuel NO_x can be formed from nitrogen-

containing fuels. For biomass combustion, fuel bound nitrogen is the main source of NOX emissions, while thermal and prompt NOX are not relevant due to relatively low temperatures as has been shown by theoretical and experimental investigations.^{4,18} Fuel nitrogen is converted to intermediate components such as HCN and NH_i with i = 0, 1, 2, 3. These can be oxidized to NOX if oxygen is available, which is the case in conventional combustion. If no oxygen is present, intermediates can interact in the reduction zone and form N₂ in reactions such as NO + NH₂ → N₂ + H₂O. During the past 10 years, staged combustion technologies have been developed as a primary measure for process internal NOX reduction based on this concept, thus leading to the above described techniques of air staging and fuel staging. Both measures enable a NOX reduction on the order of up to 50% for wood with low and up to 80% for bio fuels with high nitrogen content. However, different specific conditions have to be met accurately to exhaust this reduction potential. In the case of air staging, a primary air excess around 0.7, a temperature in the reduction zone of 1150 °C and a residence time of 0.5 s are needed. The relatively high temperature can limit the application in practice due to undesired ash softening and deposit formation. For fuel staging, similar results are achieved at lower temperature, i.e., already at temperatures as low as 850 °C.²² However, the furnace concept and operation is more complex due to the need of two independent fuel feeding systems. Nevertheless, a pilot plant based on this concept has been successfully realized with a combination of understoker furnace and entrained flow reactor. For both types of staged combustion, accurate process control is needed to ensure an operation at the excess air ratio needed in the different zones.

Besides primary measures, secondary measures are available for NOX abatement. The most relevant techniques are selective non-catalytic reduction (SNCR) and selective catalytic reduction (SCR) using the same reaction as mentioned for staged combustion, i.e., NO + NH₂ → N₂ + H₂O. However, urea or ammonia is injected as reducing agent and as source of NH₂. SNCR has to be applied in a narrow temperature window around 820 °C to 940 °C, thus enabling a NOX reduction up to 90%.²⁴ SCR is typically applied in the flue gas in a temperature range around 250° to 450 °C and enables a NOX reduction of more than 95%.²⁴ However, relevant concentrations of undesired side products such as HNCO, N₂O, NH₃, HCN, and others can be formed in both types of secondary measures under unfavorable conditions. Hence, primary measures are preferable if they can achieve sufficient emission reduction.

Particulate Emissions

Biomass combustion leads to relatively high emissions of particulates, i.e., well above 50 mg/m³ at 11 vol % O₂.^{4,25} The majority of the particulates are smaller than 10 μm (i.e., particulate matter PM₁₀) with a high share of submicron particles (PM₁). The composition of submicron and supermicron particles in fluidized bed combustion is distinctive as the fine particles are composed mainly of K, Cl, S, Na, and Ca and the coarse particles of Ca, Si, K, S, Na, Al, P, and Fe.³⁰ In fixed bed combustion, increasing mass concentrations of particulate emissions are typically related to increasing mean diameter.³¹ Further, a dependency of the particle

composition on size can also be found in fixed bed conditions, as K, S, Cl, and Zn are mainly found in the submicron fraction, while the content of Ca is increasing with increasing particle size.³² If almost complete burnout is achieved by appropriate furnace design, the particulates result almost exclusively from ash components in the fuel with salts such as KCl as main components.³³ The main fuel constituents with respect to aerosol formation are typically K, Cl, S, Ca, Na, Si, P, Fe, and Al. Primary measures which can safely meet a high reduction potential, i.e., by at least a factor of 10, of this category of aerosols are not known so far.

Combustion Technologies

Biomass combustion is mainly used for heat production in small and medium scale units such as wood stoves, log wood boilers, pellet burners, automatic wood chip furnaces, and straw-fired furnaces. Distinct heating systems are often in the size range from 0.5 MWth to 5 MWth with some applications up to 50 MWth. Combined heat and power production (CHP) with biomass is applied by steam cycles (Rankine cycle) with steam turbines and steam engines and organic Rankine cycles (ORC) with typical power outputs between 0.5MW and 10 MW.³⁵ Stirling engines (10 kW to 100 kW) and closed gas turbines are in development or demonstration mode. Co-firing in fossil-fired power stations enables the advantages of large size plants (>100 MW), which are not applicable for dedicated biomass combustion due to limited local biomass availability.

The systems can be distinguished by the flow conditions in the furnace, thus describing fixed bed combustion, fluidized bed, and entrained flow or dust combustion. To achieve complete burnout and high efficiencies in small scale combustion, downdraft boilers with inverse flow have been introduced, which apply the two-stage combustion principle described above. An operation of log wood furnaces at very low load should be avoided as it can lead to high emissions of unburnt pollutants. Hence, it is recommended to couple log wood boilers to a heat storage tank. Since wood pellets are well suited for automatic heating at small heat outputs as needed for today's buildings, pellet furnaces are an interesting application with growing propagation. They are applied both as stoves and as boilers. Understoker furnaces are mostly used for wood chips and similar fuel with relatively low ash content while grate furnaces can also be applied for highash and water content.

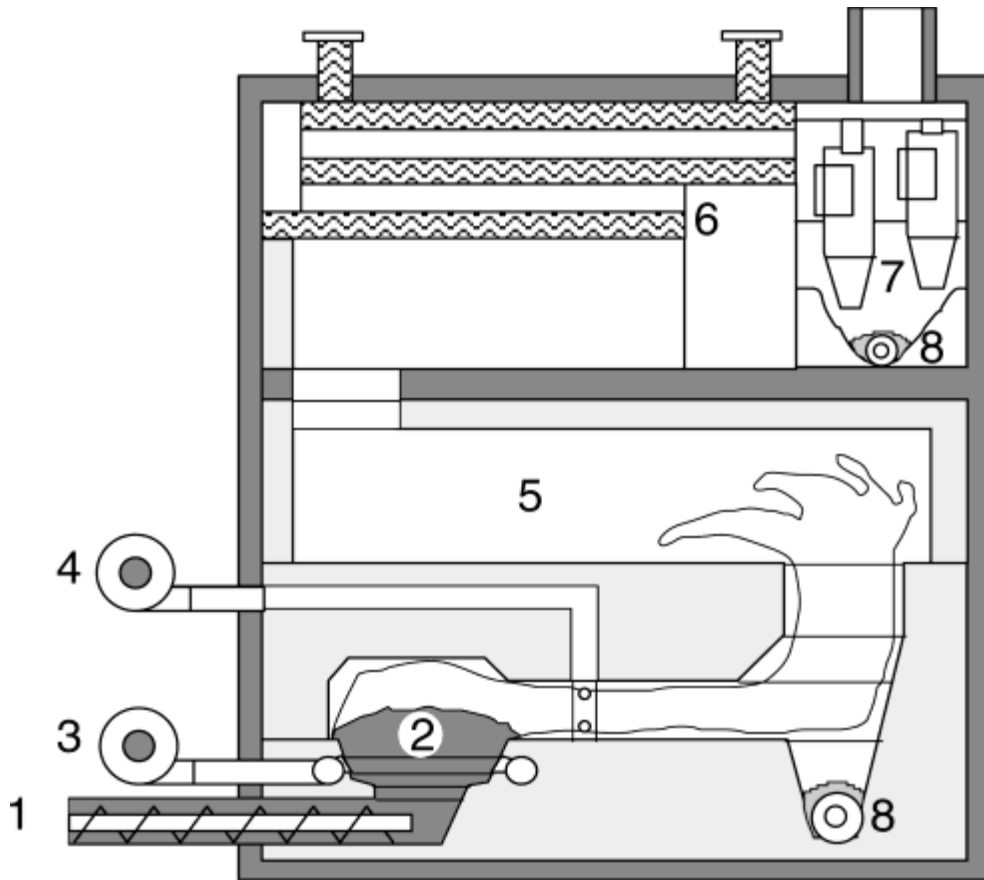

Figure . Understoker furnace with primary and secondary air, mixing zone, and post combustion chamber. 1 Screw feeder, 2 understoker zone with glow bed, 3 primary air, 4 .secondary air, 5 post combustion chamber, 6 heat exchanger,7 cyclone, 8 ash removal

Special types of furnaces have been developed for straw that has very low density and is usually stored in bales. Beside conventional grate furnaces operated with whole bales, cigar burners and other specific furnaces are in operation. Stationary or bubbling fluidized bed (SFB) as well as circulating fluidized bed (CFB) boilers are applied for large-scale applications and often used for waste wood or mixtures of wood and industrial wastes, e.g., from the pulp and paper industry. In CFB boilers, nearly homogeneous conditions of temperature and concentrations can be achieved, thus enabling high burnout quality at low excess air. The choice of different bed materials in CFB offers additional opportunities of catalytic effects. Further, the option of heat removal from the bed allows controlling the combustion temperature and hence enables an operation at low excess air without excessive ash sintering. Since similar conditions for nitrogen conversion as by air and fuel staging are attained, relatively low NOX emissions are achieved.

Co-combustion

Overview on Co-utilization.

A co-utilization of biomass with other fuels can be advantageous with regard to cost, efficiency, and emissions. Lower specific cost and higher efficiencies of large plants can be utilized for biomass and co-firing can reduce emissions of SOX and NOX. However, attention must be paid to increased deposit formation in the boiler and limitations in ash utilization due to constituents in biomass, especially alkali metals that may disable the use of ash in building materials. Due to undesired changes of ash compositions, the share of biomass is usually limited to approximately 10% of the fuel input. Hence, other opportunities are also of interest and the following three options for co-utilization of biomass with coal are applied:

(a) Co-combustion or direct co-firing: The biomass is directly fed to the boiler furnace (fluidized bed, grate, or pulverized combustion), if needed after physical preprocessing of the biomass such as drying, grinding, or metal removal.

(b) Indirect co-firing: The biomass is gasified and the product gas is fed to a boiler furnace (thus a combination of gasification and combustion).

Parallel combustion:

The biomass is burnt in a separate boiler for steam generation. The steam is used in a power plant together with the main fuel. Co-combustion of biomass leads to a substitution of fossil fuels and to a net reduction of CO₂ emissions. In many countries co-firing is the most economic technology to achieve the target of CO₂ reduction and savings of CO₂ taxes can therefore motivate biomass co-firing.

Co-combustion or Direct Co-firing with Coal

The main application nowadays is direct co-firing in coal-fired power stations. The typical size range is from 50 MW to 700 MW with a few units between 5 and 50 MW. The majority of the plants are equipped with pulverized coal boilers in which co-combustion can be applied in different ways.

- a. The biomass can be burnt in separate wood burners in the boiler. Due to the requirements of pulverized combustion, drying, metal separation, and grinding of the biomass is needed as pretreatment. An example is shown in a 635 MW power plant in the Netherlands that burns the majority of the local urban waste wood and demolition wood. Wood replaces 3%-4% of the coal in this plant. Thanks to the scale and the flue gas cleaning, the urban waste wood is used with high efficiency and low environmental impact. At an electric efficiency of the plant of 43%, the net efficiency for wood with

regard to fuel pretreatment is estimated at 36%-38%. As comparison: a modern 25 MW wood-based fired plant reaches 30% efficiency.

- b. As an alternative, the biomass can also be burnt on a separate grate at the bottom of a pulverized coal boiler. The advantage is that costly and energy-consuming fuel pretreatment is not needed, since biomass with high water content and large in size can be burnt.
- c. Further applications of co-combustion with coal are related to BFB, CFB, cyclone, and stoker boilers, which accept a much wider range of fuel size, composition, and moisture content than burners in pulverized coal boilers.

Effects of Co-combustion on Plant Operation and Emissions

Co-firing can have several effects on the emissions and the plant operation: positive effects are that SOX and NOX emissions usually decrease due to the lower sulfur and nitrogen content in biomass than in coal. Furthermore, alkali components in biomass ash can have an effect of SOX removal. Since biomass has a high volatile content, it can also be used as reburn fuel for NOX reduction from the coal combustion, which gives a further potential for significant decrease of the NOX emissions. Besides NO and NO₂, also N₂O can be significantly reduced by co-firing of biomass in coal-fired fluidized bed boilers.

Negative effects of co-firing are additional investment cost for biomass pretreatment and boiler retrofitting, higher operation cost due to increased fouling and corrosion, and a possible decrease of the electric efficiency (if the superheater temperature has to be decreased due to high temperature corrosion). Besides potential poisoning of SCR catalyst also the efficiency of electrostatic precipitators may be reduced. Furthermore, the utilization of the ash and the residues from the flue gas cleaning system (especially the De-SOX installation) has to be considered when co-firing biomass. The ash quality can be negatively influenced mainly by alkali metals and chlorine contained in biomass. Furthermore, also the content of unburnt carbon can increase. Usually a biomass input in the range of 5% to 10% according to the energy input is acceptable without major influence on the residues.

Other Applications of Co-combustion

Co-firing of biomass can also be applied in cement kilns, which is of special interest for contaminated waste wood. Additionally, biomass fuels can be co-fired in municipal solid waste (MSW) incinerators. This can be advantageous with respect to logistics and efficiency, since biomass can easily be stored while municipal waste needs to be burnt immediately. Further, the combination of biomass with oil or natural gas also offers specific advantages. Especially the topping with natural gas enables a significant increase of the plant efficiency, since steam from a biomass boiler can be superheated to higher temperatures with natural gas.

Indirect Co-firing and Parallel Combustion

Parallel combustion enables a complete separation of the ashes and flue gases from different fuels such as biomass and coal. Hence, no disadvantages or limitations result from undesired alkali metals or contaminants in the ash. Further, the flue gas cleaning equipment can be optimized for each fuel. Indirect co-firing of producer gas from biomass gasification also enables the separation of the ashes to a certain extent, while the flue gases cannot be separated. In comparison to parallel combustion, investment cost can be reduced because only one boiler and flue gas cleaning are needed.

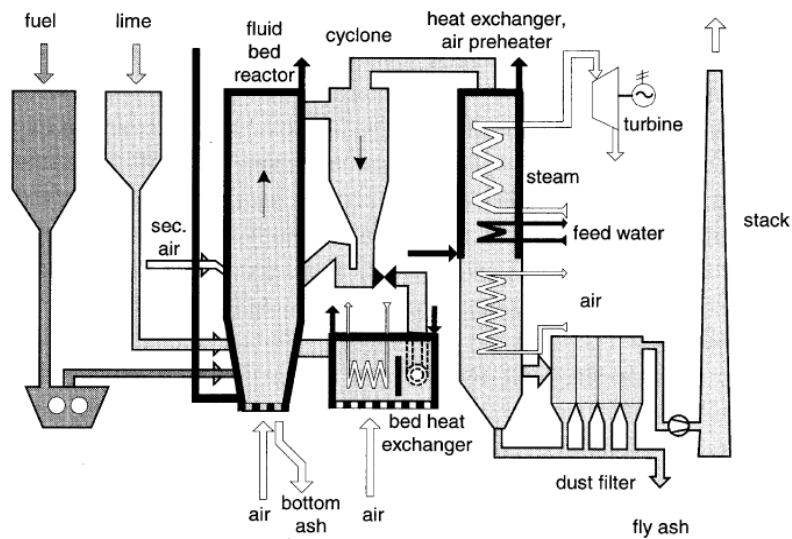

Combustion and co-combustion of biomass

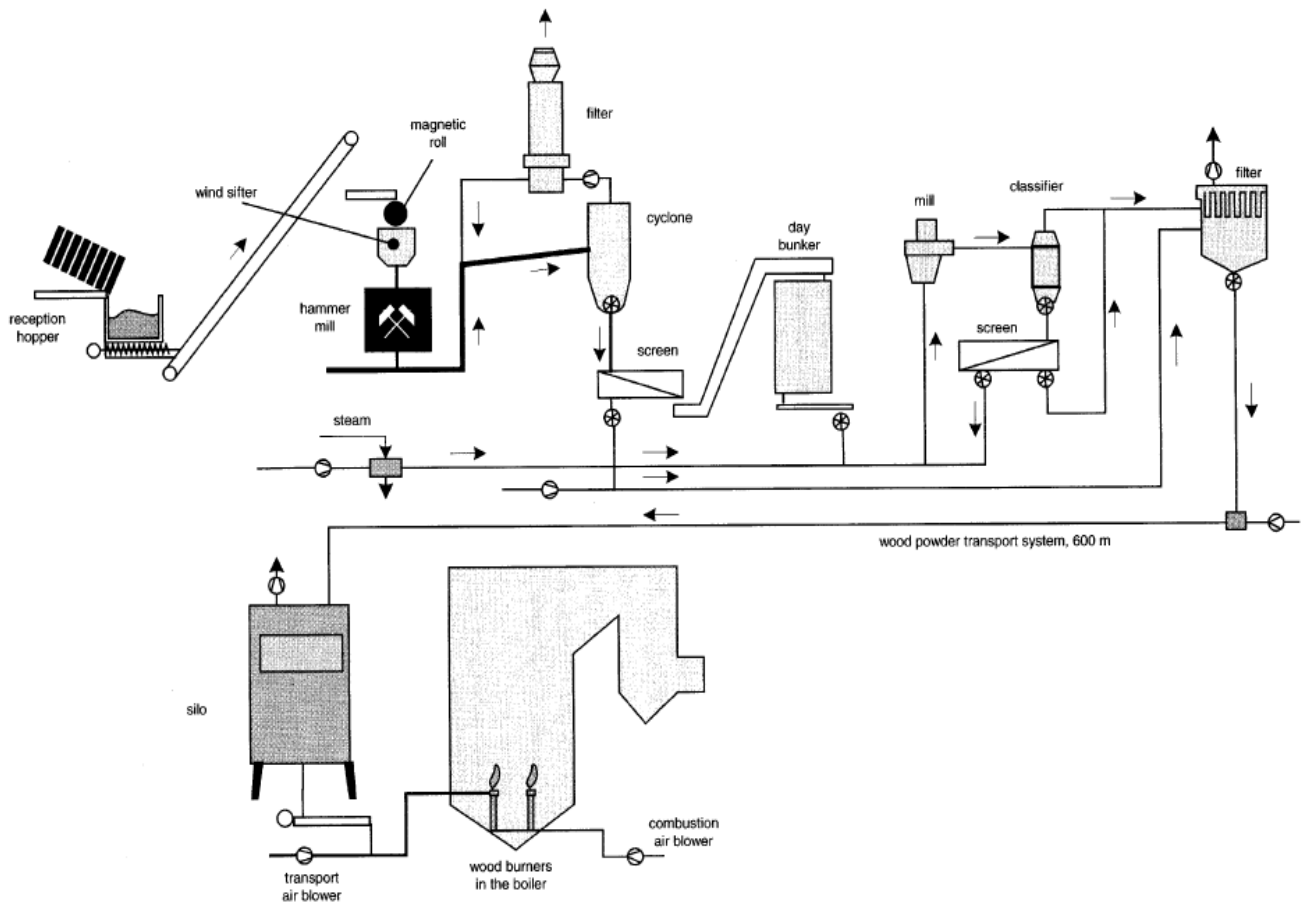

Lecture-7

Gasifier Technology

Gasification

The process to convert biomass solid raw material into fuel gas or chemical feedstock gas (syngas) is called gasification or thermochemical gasification.

Gasification agent

In order to convert solid biomass into inflammable gas, a substance to promote the chemical reaction is necessary. This substance is called the gasification agent, and mainly air (N₂, O₂), oxygen (O₂), H₂O, or CO₂ are applied as an appropriate mixture. Air (only O₂ reacts) and O₂ heat by oxidation, and increased O₂ decreases the effective amount of inflammable gas.

Fundamental phenomenon of biomass gasification

Fundamental gasification processes are as follows:

(a) Evaporation of surface moisture

Surface moisture evaporates from the raw material at the water boiling point (depends on pressure). Inner moisture remains when the raw material is large.

(b) Evaporation of inherent moisture

Following surface moisture evaporation, inherent moisture evaporates at 110-120° C.

(c) Volatilization

Thermal decomposition of biomass begins at 200-300° C, and CO, CO₂, H₂ and H₂O are vaporized as gas. Thermal decomposition is a heat generating reaction which is a characteristic phenomenon of biomass (C_nH_mO_p).

(d) Volatilization and gasification reaction

The temperature is raised further during volatilization, and the volatile matter of the lightweight hydrocarbons (C_xH_y: where x and y are integers of at least 1; a low value of x indicates lightness and a high value of x indicates heaviness) is transformed into heavy C_xH_y with a high boiling point. Subsequently, the C_xH_y reacts with the gasifying agent for conversion to lightweight molecule clean gas, although tar and soot can form when diffusion of the gasifying agent is slow and the C_xH_y condenses.

(e) Char gasification

Following volatilization of the volatile content in the raw material biomass, the fixed carbon and ash become char, and the char is heated to the surrounding temperature. The subsequent reaction with the gasifying agent transforms the carbon into CO and CO₂. However, in cases where the gasifying agent contains excess steam and the surrounding temperature is over 750° C, a wet gas reaction occurs ($C+H_2O \rightarrow CO+H_2$) producing gas composed mainly of CO, CO₂ and H₂.

(f) Char residue

The reaction rate of the wet gas reaction is slow, and char residue can easily form. The formation of tar, soot and char tends to reduce efficiency, as well causing equipment trouble.

Characteristics of gasification product gas

Gasification generally adopts the direct gasification method with partial combustion of raw material to raise the temperature. Raw materials are mainly wood chips and corn stalks. Most gasification furnaces use normal pressure and a direct gasification process. To keep the reaction temperature at 800° C and above for direct gasification, air, oxygen and steam (as appropriate) are required for the gasification agent. For this purpose, approximately 1/3 of the oxygen required for complete combustion (known as the oxygen ratio) is supplied, with partial combustion (partial oxidation) causing gasification. The calorific value of product gas depends on the percentage of inflammable gas (CO, H₂, C_xH_y) contained. Generally, gas can be divided into low calorie gas (4-12 MJ/m³), medium calorie gas (12-28 MJ/m³) and high calorie gas (above 28 MJ/m³). For the most part, direct gasification of biomass yields low calorie gas. Fig. 4.2.1 presents composition of the product gas from rice straw when steam and oxygen is employed as gasifying agent. The ratio between the calorific content of the biomass and that of the product gas (at room temperature) is called cold gas efficiency.

Gasification equipment and a practical example

Here is shown a fixed bed gasifier, based on the combustion or gasification of solid fuel, and featuring a comparatively simple structure and low equipment cost. Fig. 4.2.2 shows a concept diagram of the gasifier. Wood chips of about 2.5-5 cm are generally used as the raw material. They are supplied from the upper feed port, and layered in the furnace. The gasifying agent (air, oxygen, steam or a mixture thereof) is supplied from the bottom in a rising flow (some systems use a descending flow). The gasification reaction proceeds from the bottom towards the top. From the bottom upward, individual layers are formed due to the changes accompanying gasification of the raw material, in the order of ash, char, volatilized and decomposed material, and product. The product gas is obtained at the top.

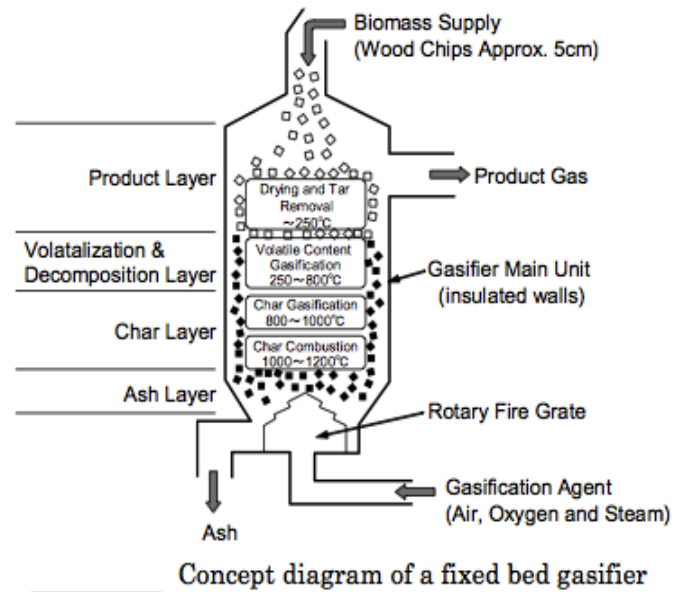
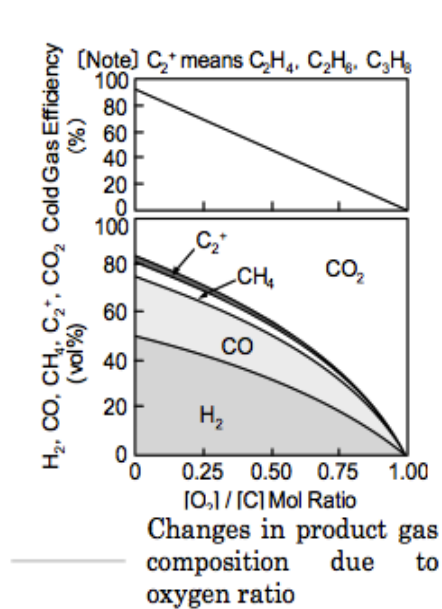

Principles of solid fuel gasification

All internal combustion engines actually run on vapor, not liquid. The liquid fuels used by gasoline engines are vaporized before they enter the combustion chamber above the pistons. In diesel engines, the fuel is sprayed into the combustion chamber as fine droplets which burn as they vaporize.

The purpose of a Gasifier, then, is to transform solid fuels into gaseous ones and to keep the gas free of harmful constituents. A gas generator unit is simultaneously an energy converter and a filter. In these twin tasks lie its advantages and its difficulties. In a sense, gasification is a form of incomplete combustion-heat from the burning solid fuel creates gases which are unable to burn completely because of the insufficient amounts of oxygen from the available supply of air. The same chemical laws, which govern combustion processes, also apply to gasification. There are many solid biomass fuels suitable for gasification - from wood and paper to peat, lignite, and coal, including coke derived from coal. All of these solid fuels are composed primarily of carbon with varying amounts of hydrogen, oxygen, and impurities, such as sulfur, ash, and moisture. Thus, the aim of gasification is the almost complete transformation of these

Renewable Energy

constituents into gaseous form so that only the ashes and inert materials remain. In creating wood gas for fueling internal combustion engines, it is important that the gas not only be properly produced, but also preserved and not consumed until it is introduced into the engine where it may be appropriately burned.

Gasification is a physicochemical process in which chemical transformations occur along with the conversion of energy. The chemical reactions and thermochemical conversions which occur inside a wood gas generator are too long and too complicated to be covered here; however, such knowledge is not necessary for constructing and operating a wood Gasifier. By weight, gas (wood gas) produced in a Gasifier unit contains approximately 20% hydrogen (H₂), 20% carbon monoxide (CO), and small amounts of methane, all of which are combustible, plus 50 to 60% nitrogen (N₂). The nitrogen is not combustible; however, it does occupy volume and dilutes the wood gas as it enters and burns in an engine. As the wood gas burns, the products of combustion are carbon dioxide (CO₂) and water vapor (H₂O).

One of the by-products of wood gasification is carbon monoxide, a poisonous gas. The toxic hazards associated with breathing this gas should be avoided during refueling operations or prolonged idling, particularly in inadequately ventilated areas. Except for the obvious fire hazard resulting from the combustion processes inside the unit, carbon monoxide poisoning is the major potential hazard during normal operation of these simplified Gasifier units.

The Stratified Downdraft Gasifier

Until the early 1980s, wood gasifiers all over the world (including the World War II designs) operated on the principle that both the fuel hopper and the combustion unit be absolutely airtight; the hopper was sealed with a top or lid which had to be opened every time wood was added. Smoke and gas vented into the atmosphere while wood was being loaded; the operator had to be careful not to breathe the unpleasant smoke and toxic fumes. Over the last few years, a new Gasifier design has been developed through cooperative efforts among researchers at the Solar Energy Research Institute in Colorado, the University of California in Davis, the Open University in London, the Buck Rogers Company in Kansas, and the Biomass Energy Foundation, Inc., in Florida. This simplified design employs a balanced, negative-pressure concept in which the old type of sealed fuel hopper is no longer necessary. A closure is only used

to preserve the fuel when the engine is stopped. This new technology has several popular names, including "stratified, downdraft gasification" and "open top gasification."

Several years of laboratory and field-testing have indicated that such simple, inexpensive gasifiers can be built from existing hardware and will perform very well as emergency units. A schematic diagram of the stratified, downdraft Gasifier is shown in Fig. S-1. During operation of this Gasifier, air passes uniformly downward through four zones, hence the name stratified: The uppermost zone contains unreacted fuel through which air and oxygen enter. This region serves the same function as the fuel hopper in the older, World War II designs. In the second zone, the wood fuel reacts with oxygen during pyrolysis. Most of the volatile components of the fuel are burned in this zone and provide heat for continued pyrolysis reactions. At the bottom of this zone, all of the available oxygen from the air should be completely reacted. The open top design ensures uniform access of air to the pyrolysis region. The third zone is made up of charcoal from the second zone. Hot combustion gases from the pyrolysis region react with the charcoal to convert the carbon dioxide and water vapor into carbon monoxide and hydrogen. The inert char and ash, which constitute the fourth zone, are normally too cool to cause further reactions; however, because the fourth zone is available to absorb heat or oxygen as conditions change, it serves both as a buffer and as a charcoal storage region. Below this zone is the grate. The presence of char and ash serves to protect the grate from excessive temperatures.

The stratified, downdraft design has a number of advantages over the World War II gasifier designs. The open top permits fuel to be fed more easily and allows easy access. The cylindrical shape is easy to fabricate and permits continuous flow of fuel. No special fuel shape or pretreatment is necessary; any blocky fuel can be used. The foremost question about the operation of the stratified, downdraft gasifier concerns char and ash removal. As the charcoal reacts with the combustion gases, it eventually reaches a very low density and breaks up into a dust containing all of the ash as well as a percentage of the original carbon. This dust may be partially carried away by the gas and might eventually begin to plug the gasifier.

Hence, it must be removed by shaking or agitation. When the stratified gasifier unit is used to power vehicles, it is automatically shaken by the vehicle's motion. An important issue in the design of the stratified, downdraft gasifier is the prevention of fuel bridging and channeling. High-grade biomass fuels, such as wood blocks or chips, will flow down through the gasifier

because of gravity and downdraft air flow. However, other fuels (such as shredded chips, sawdust, and bark) can form a bridge, which will obstruct continuous flow and cause very high temperatures. Bridging can be prevented by stirring, shaking, or by agitating the grate or by having it agitated by the vehicle's movement. For prolonged idling, a hand-operated shaker has been included in the design in this report.

A prototype unit of the stratified, downdraft gasifier design (see Figs. S-2 and S-3) has been fabricated according to the instructions in this report; however, it has not been widely tested at this time. The reader is urged to use his ingenuity and initiative in the construction of his own wood gas generator. As long as the principle of air tightness in the combustion regions, in the connecting piping, and in the filter units is followed, the form, shape, and method of assembly is not important. The wood gasifier design presented in this report has as its origin the proven technology used in World War II during actual shortages of gasoline and diesel fuel. It should be acknowledged that there are alternate technologies (such as methane production or use of alcohol fuels) for keeping internal combustion engines in operation during a prolonged petroleum crisis. The wood gasifier unit described in this report represents only one solution to the problem.

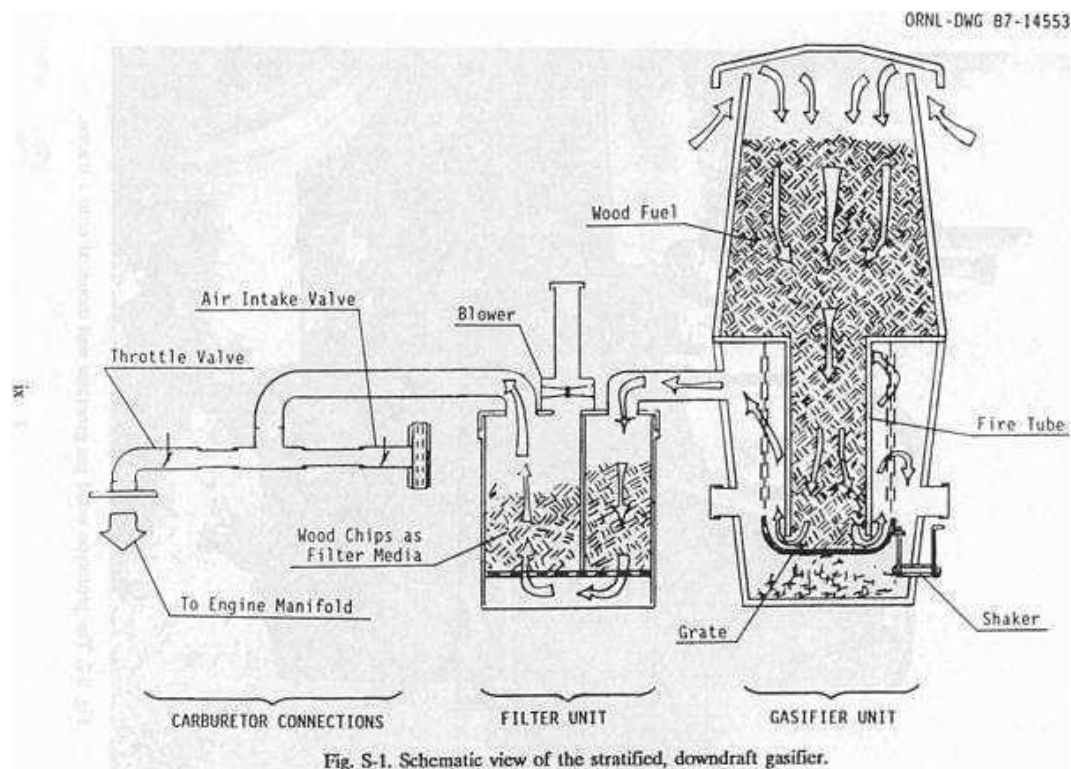

Fig. S-1. Schematic view of the stratified, downdraft gasifier.

Imbert' Gasifier

The constricted hearth, downdraft Gasifier is sometimes called the 'Imbert' Gasifier after its inventor, Jacques Imbert; although, it has been commercially manufactured under various names. Such units were mass-produced during World War II by many European automotive companies, including General Motors, Ford, and Mercedes-Benz. These units cost about \$1500 (1985 evaluation) each. However, after World War II began in 1939, it took six to eight months before factory-made gasifiers were generally available. Thousands of Europeans were saved from certain starvation by home-built, simple Gasifier units made from washing machine tubs, old water heaters, and metal gas or oxygen cylinders. Surprisingly, the operation of these units was nearly as efficient as the factory-made units; however, the homemade units lasted for only about 20000 miles with many repairs, while the factory-made units operated, with few repairs, up to 100,000 miles. In Fig. 1-2 the upper cylindrical portion of the Gasifier unit is simply a storage bin or hopper for wood chips or other biomass fuel. During operation, this chamber is filled every few hours as needed. The spring-loaded, airtight cover must be opened to refill the fuel hopper; it must remain closed and sealed during Gasifier operation. The spring permits the cover to function as a safety valve because it will pop open in case of any excessive internal gas pressure. About one-third of the way up from the bottom of the Gasifier unit, there is a set of radially directed air nozzles; these allow air to be injected into the wood as it moves downward to be gasified. In a gas generator for vehicle use, the down stroke of the engine's pistons creates the suction force which moves the air into and through the Gasifier unit; during startup of the Gasifier a blower is used to create the proper airflow. The gas is introduced into the engine and consumed a few seconds after it is made. This gasification method is called "producer gas generation," because no storage system is used; only that amount of gas demanded by the engine is produced. When the engine is shut off, the production of gas stops. During normal operation, the incoming air burns and pyrolyzes some of the wood, most of the tars and oils, and some of the charcoal that fills the constricted area below the nozzles.

Most of the fuel mass is converted to gas within this combustion zone. The Imbert Gasifier is, in many ways, self-adjusting. If there is insufficient charcoal at the air nozzles, more wood is burned and pyrolyzed to make more charcoal. If too much charcoal forms, then the charcoal level rises above the nozzles, and the incoming air burns the charcoal. Thus, the

Renewable Energy

combustion zone is maintained very close to the nozzles. Below this combustion zone, the resulting hot combustion gases - carbon dioxide (CO₂) and water vapor (H₂O) - pass into the hot charcoal where they are chemically reduced to combustible fuel gases: carbon monoxide (CO) and hydrogen (H₂). The hearth constriction causes all gases to pass through the reaction zone, thus giving maximum mixing and minimum heat loss. The highest temperatures are reached in this region. Fine char and ash dust can eventually clog the charcoal bed and will reduce the gas flow unless the dust is removed. The charcoal is supported by a movable grate which can be shaken at intervals. Ash buildup below the grate can be removed during cleaning operations. Usually, wood contains less than 1% ash (by weight). However, as the charcoal is consumed, it eventually collapses to form a powdery charcoal/ash mixture which may represent 2 to 10% (by weight) of the total fuel mass.

The cooling unit required for the Imbert Gasifier consists of a water filled precipitating tank and an automotive radiator type gas cooler. The precipitating tank removes all unacceptable tars and most of the fine ash from the gas flow, while the radiator further cools the gas. A second filter unit, containing a fine mesh filtration material, is used to remove the last traces of any ash or dust that may have survived passage through the cooling unit. Once out of the filter unit, the wood gas is mixed with air in the vehicle's carburetor and is then introduced directly into the engine's intake manifold. The World War II, Imbert Gasifier requires wood with a low moisture content (less than 20% by weight) and a uniform, blocky fuel in order to allow easy gravity feed through the constricted hearth. Twigs, sticks, and bark shreds cannot be used. The constriction at the hearth and the protruding air nozzles present obstructions to the passage of the fuel and may create ridging and channeling followed by poor quality gas output, as unpyrolyzed fuel falls into the reaction zone.

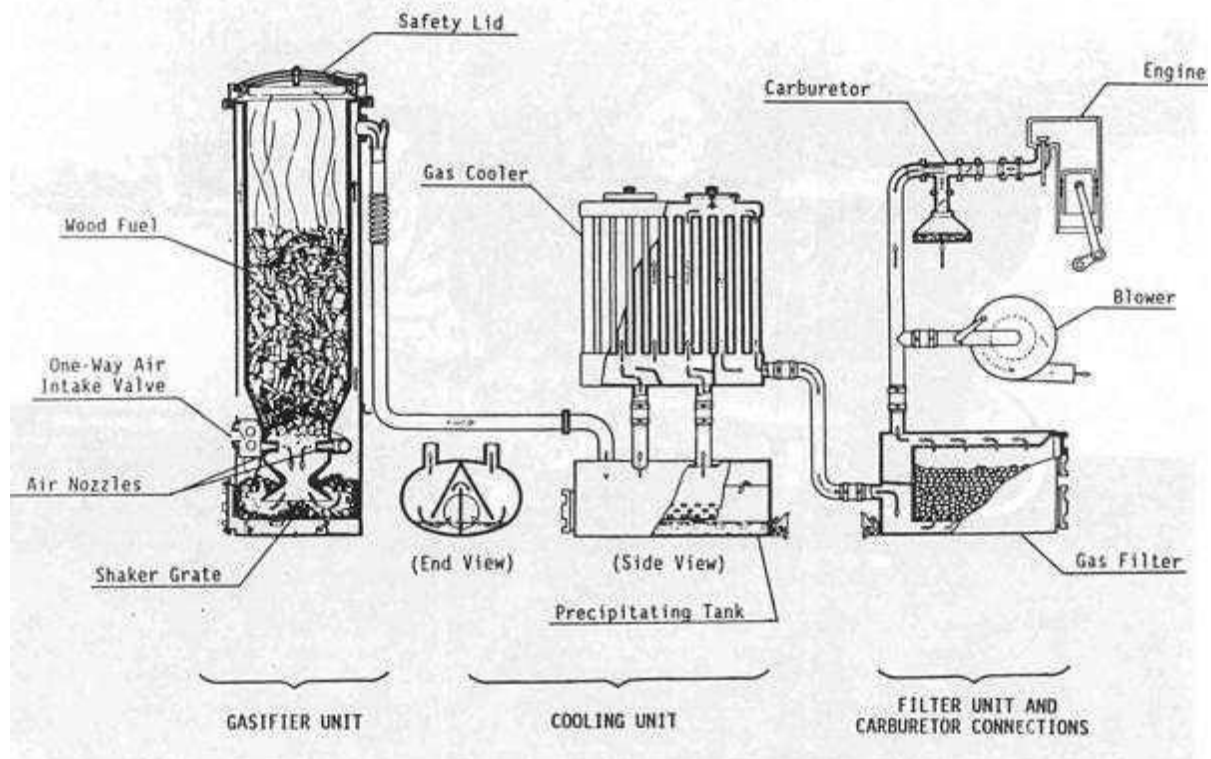

Fig. 1-2. Schematic view of the World War II, Imbert gasifier.

SUGARCANE LEAF-BAGASSE GASIFIERS

Certain critical engineering design norms of the gasification system were first developed on a laboratory-scale model and were then validated on a bench-scale model 6, 7 . These norms were then used to design a full-fledged commercial scale system with a thermal output of 1080 MJ h⁻¹ . This system (presently installed in the NARI campus) is seen in Fig. 1. It comprises of a reactor, a gas conditioning system, a biomass feeding system and the instrumentation and controls. A schematic diagram of this system is shown in Fig. 2. The salient features of these components are given below.

Reactor : This was a downdraft, throatless and open-top reactor with an internal diameter of 75 cm and an active bed height of 1.25 m. It was designed for a heavy-duty cycle of 7500 hour per year operation. High temperature resisting firebricks conforming to IS 8 grade were used for the hot face followed by a cold face insulation.

Gas conditioning system : A completely dry dust collection system eliminated altogether the problem of wastewater. This consisted of a high temperature char/ash coarse settler and a high efficiency cyclone separator. A specifically designed high temperature resisting induced-draft fan ensured that the entire system is under negative pressure so that in the event of leaks, outside air got sucked into the system, but the combustible gas did not leak out. Thus, this design is very environment-friendly. The char-ash from the coarse settler and the cyclone was collected in barrels and emptied in an ash pit once every forty-five minutes. This char-ash which typically has a gross calorific value of 18.9 MJ kg⁻¹ can be briquetted to form an excellent fuel, or can be used as a soil conditioner 8, 9 .

Biomass feeding system : This consisted of a scraper drag-out conveyor and a hopper to convey the biomass fuel from the storage pile to the reactor. The conveyor was completely enclosed.

Instrumentation and Control System : A Programmable Logic Controller (PLC)-based control system seen in Fig. 3 was designed to take automatic corrective actions under certain critical conditions. Thus, the biomass feeding and ash removal rates were fully controlled by this system. Besides, it also helped the operator in trouble-shooting by monitoring temperatures at various critical points in the gasification system. Automatic burner sequence controllers were provided for ignition of the producer gas.

The gasification system was extremely simple to operate. A cold start took about ten-fifteen minutes whereas a hot start was affected in less than five minutes. Only two operators per shift of eight hours were required to operate the system, including the fuel and ash handling operations.

Lecture 8

Biomass gasification methods

Thermochemical conversion method – Principle – Gasifiers – Operation-types-Applications

The thermo-chemical decomposition of hydrocarbons from biomass in a reducing (oxygen deficient) atmosphere is called gasification. The resulting gas product contains combustible gases – hydrogen (H_2) and carbon monoxide (CO) as the main constituents. Byproducts are liquids and tars, charcoal and mineral matter (ash or slag). Reducing atmosphere of the gasification stage means that only 20% to 40% of stoichiometric amount of oxygen (O_2) related to a complete combustion enters the reaction. This is enough to cover the heat energy necessary for a complete gasification. It creates sensible heat necessary to complete gasification from its own internal resources.

Biomass gasification is basically the conversion of solid biomass such as wood, agricultural residues etc., into a combustible gas mixture normally called “producer gas” (or Low Btu gas). The solid biomass is partially burnt in the presence of air or oxygen to produce a low or medium calorific value gas. Partial combustion process occurs when air supply is less than adequate for combustion of biomass to be completed. Given that biomass contains carbon, hydrogen and oxygen molecules, complete combustion would produce carbon dioxide and water vapour. Partial combustion produces carbon monoxide as well as hydrogen which are both combustible gases

Solid biomass fuels are usually inconvenient, have low efficiency of utilisation and can only be used for certain limited applications. Combustion is the normal conversion process used in cooking, heating space and water, or generation of steam usually with low efficiencies, generation of power, for example, requires high/medium pressure steam boiler along with steam engine or turbine with accessories. For small power needs (a few kilowatts to few hundred kilowatts), this conversion technology is not only capital intensive and complex, but also very inefficient.

Conversion of the same biomass to a combustible gas mixture called producer gas removes most of these problems associated with the use of solid biomass fuels. While conversion to gas results in loss of energy of upto 25 percent, use of gas can be highly

efficient and hence overall efficiency could be very high. Also it can be employed at any scale and hence is ideally suited for decentralised application whether for shaftpower, electricity or thermal energy.

Biomass Gasifier-an attractive technology option

Renewed emphasis on increased use of bio-resources does not obviously imply going back to traditional, inefficient and inconvenient techniques and devices. These resources obviously need to be utilised in keeping with modern-day conveniences and efficiencies that people are so used to by now. This indeed is the most basic and vital difference between the past and expected future scenario in which biomass is seen as playing an important role.

Numbers of thermal applications of gasifier systems have shown adequate and immediate promise. These applications involve diverse situations: situation where biomass might already be in use with traditional technologies; situations where biomass may not be currently in use but is available as a by-product; and situations where biomass may need to be procured for a switch over from fossil fuel. However even in situations where thermal energy is currently being provided by bio-resources, careful study of the application and effective development of application packages becomes necessary

The gas from the gasifier burns completely; it is clean, odourless and colourless. The fuel gas can be directly mixed with cold air to generate hot air at desired temperature for purpose of drying. Furthermore the producer gas can also be used to replace diesel (upto 70-75 percent) in standard diesel engine for shaft power generation comparable to conventional electricity at substantially lower cost than for diesel based generation. The gasifier is also environment friendly equipment without any harmful emission.

Biomass as a Source of Energy

The world over, biomass fuels represent the second largest source of energy used after fossil fuels. In developing countries about two thousand million people rely almost entirely on biomass fuels for their energy needs. It represents about 35 percent of the energy used. About 40 percent of the total energy consumed in India, even today, comes from fuelwood, charcoal and various agricultural residues. About half of all the trees cut in the world, for whatever reasons, end up being used as fuel for cooking and heating. The present methods for utilization of these resources are highly inefficient. On the other

hand, utilization of the residues through gasification route becomes economical and promising for thermal and power to rural areas and for small scale agro industries. This will also reduce the pressure on the worsening fuel wood situation. Agro residues are available abundantly and can also be used for gasification.

Prevailing chemical reactions are listed in Table 1, wherein the following main three gasification stages are described.

Stage I. Gasification process starts as auto-thermal heating of the reaction mixture. The necessary heat for this process is covered by the initial oxidation exothermic reactions by combustion of a part of the fuel.

Stage II. In the second - pyrolysis stage, being passed through a bed of fuel at high temperature pyrolyzes combustion gases. Heavier biomass molecules distillate into medium weight organic molecules and CO_2 . In this stage, tar and char are also produced.

Stage III. Initial products of combustion carbon dioxide (CO_2) and (H_2O) are reconverted by reduction reaction to carbon monoxide (CO), hydrogen (H_2) and methane (CH_4). These are the main combustible components of producer gas. These reactions, not necessarily related to reduction, occur at high temperature. Gasification reactions, most important for the final quality (heating value) of syngas, take place in the reduction zone of the gasifier. Heat consumption prevails in this stage and the gas temperature will therefore decrease. Tar is mainly gasified, while char, depending upon the technology used, can be significantly "burned", reducing the concentration of particulates in the product.

Gasification Stage	Reaction formula	Reaction heat
Stage I:	$C + 1/2O_2 \rightarrow CO$	Exothermic
Oxidation and Other exothermic Reaction	$CO + 1/2O_2 \rightarrow CO_2$ $C + O_2 \rightarrow CO_2$ $C_6H_{10}O_5 \rightarrow xCO_2 + yH_2O$ $H_2 + 1/2O_2 \rightarrow H_2O$ $CO + H_2O \rightarrow CO_2 + H_2$ $CO + 3H_2 \rightarrow CH_4 + H_2O$	
Stage II :	$C_6H_{10}O_5 \rightarrow C_xH_z + CO$	Endothermic
Pyrolysis	$C_6H_{10}O_5 \rightarrow C_nH_mO_y$	
Stage III :	$C + H_2O \rightarrow CO + H_2$	Endothermic
Gasification (Reduction)	$C + CO_2 \rightarrow 2CO$ $CO_2 + H_2 \rightarrow CO + H_2O$ $C + 2H_2 \rightarrow CH_4$	Exothermic

Table 1: Biomass gasification chemical reactions

(Source : J.B. Jones & C.A. Hawkins. Engineering Thermodynamics, 1986,P. 456)

The net product of air gasification can be found by summing of the partial reactions, as follows:

Carbohydrate matter

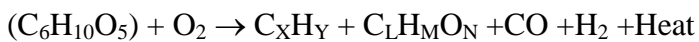

Reactions labeled in Table 2 as exothermic means that chemical energy is converted to sensible heat and reactions labeled as endothermic means that heat is consumed in favor of chemical energy.

Design of gasifier depends upon type of fuel used and whether gasifier is portable or stationary. Gasifiers are classified according to how the air blast introduced in the fuel column. History of gasification reveals several designs of gasifiers. The fixed bed gasifier has been the traditional process used for gasification, operated at temperatures around 1000 C. The most commonly built gasifiers are classified as:

Renewable Energy

- Updraft gasifiers (fig 1)
- Downdraft gasifiers (fig 2)
- Crossdraft gasifiers (fig 3)

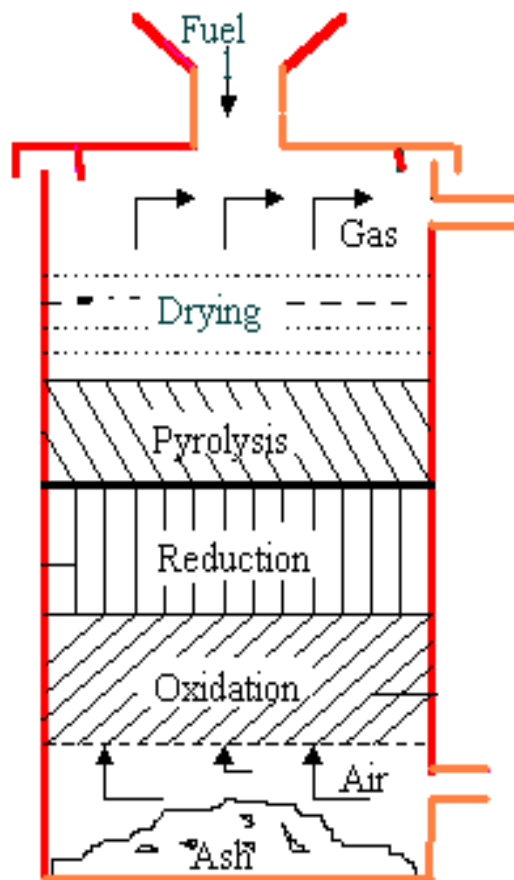

Fig.1. Updraft Gasifier

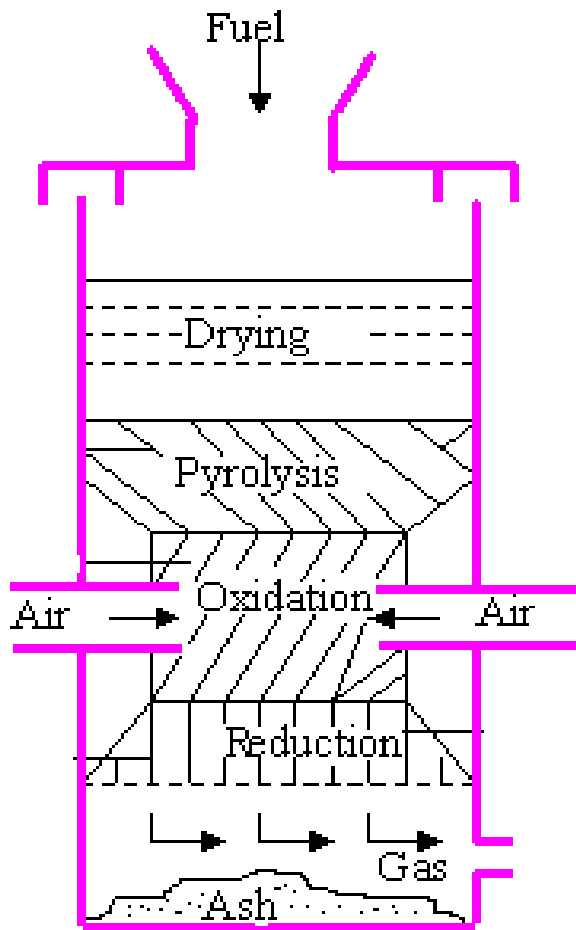

Fig.2 Downdraft Gasifier

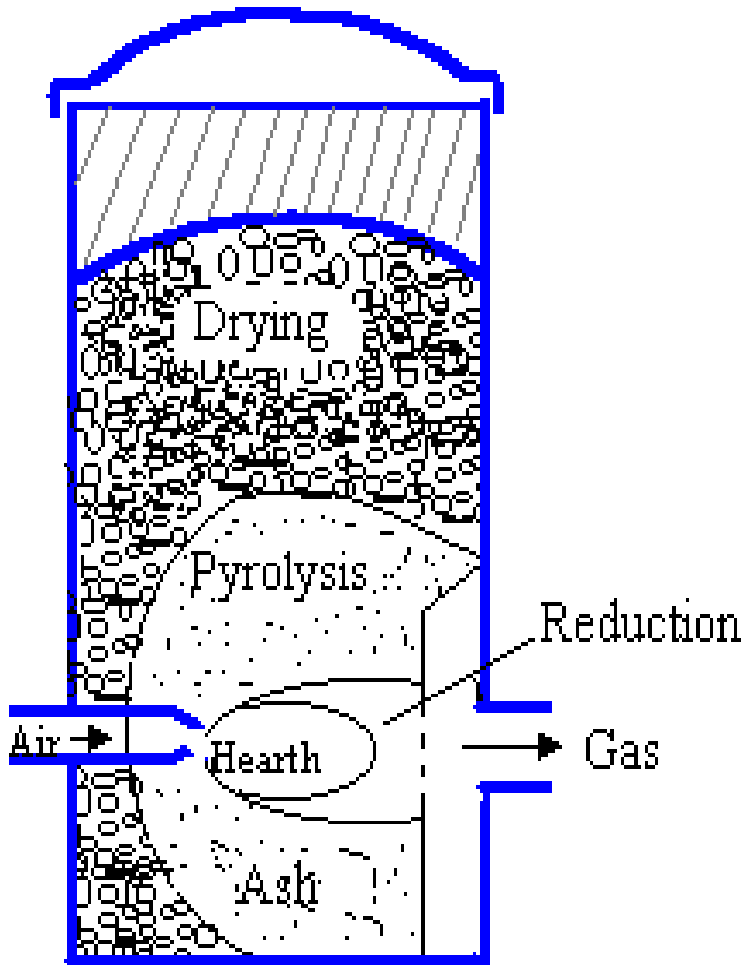

Fig.3. Crossdraft gasifier

Fluidized bed Gasification

Fluidized bed gasification has been used extensively for coal gasification for many years, its advantage over fixed bed gasifiers being the uniform temperature distribution achieved in the gasification zone. The uniformity of temperature is achieved using a bed of fine grained material into which air is introduced, fluidizing the bed material and ensuring intimate mixing of the hot bed material, the hot combustion gas and the biomass feed.

Two main types of FB gasifier are in use;

- 1.Circulating fluidized bed,
- 2.Bubbling bed.

A third type of FB is currently being developed, termed a fast, internally circulating gasifier, which combines the design features of the other two types. The reactor is still at pilot stage of development.

Circulating Fluidized bed Gasification

Circulating FB gasifier are able to cope with high capacity throughputs and are used in the paper industry for the gasification of bark and other forestry residues. The bed material is circulated between the reaction vessel and a cyclone separator, where the ash is removed and the bed material and char returned to the reaction vessel. Gasifiers can be operated at elevated pressures, the advantage being for those end use applications where the gas is required to be compressed afterwards, as in a gas turbine.

Bubbling bed gasification

Bubbling bed FB gasifiers consist of a vessel with a grate at the bottom through which air is introduced. Above the grate is the moving bed of fine-grained material into which the prepared biomass feed is introduced. Regulation of the bed temperature to 700-900°C is maintained by controlling the air/biomass ratio. The biomass is pyrolysed in the hot bed to form a char with gaseous compounds, the high molecular weight compounds being cracked by contact with the hot bed material, giving a product gas with a low tar content, typically < 1-3 g/Nm³.

Lecture 9.

Removal of tar and other impurities

Tar removal

High molecular weight compounds in the gas downstream of the gasifier begin to condense at temperatures less than 450°C. The condensed material termed tar is partly deposited on the walls of the piping and partly remaining as an aerosol in the gas. The tar content hinders the removal of particulates from the gas and also causes problems with the subsequent utilization of the product gas. The type of biomass largely determines the nature of the tar produced which is also influenced by the gasification process and the operating conditions. Air gasification produces a low viscosity /low reactivity tar with a low molecular weight. High temperature gasification gives a tar with low oxygen content, consisting mostly of hydrocarbons. Research has shown the fixed bed down draft gasifier to be most capable of producing a low tar/tar free gas.

Two strategies can be applied to the removal of tar.

1. Improvement of the gasification technology so that no /little tar is produced.
2. Development of Tar removal processes.

Tar can be cracked into lower molecular weight compounds using either catalytic or thermal processes. Catalytic cracking takes place at 800-900°C and thermal cracking at 900-1100°C. As gasification is usually in the range 800-900°C, thermal cracking requires additional energy to heat the gas, which is usually achieved by introducing a small volume of air to enable combustion of part of gas to raise the temperature. While an effective method, thermal reducing the overall efficiency of conversion of biomass energy to gasification process. Catalytic cracking is therefore preferred, using catalysts such as dolomite, olivine and nickel compounds. A uniform and high temperature has been found to be the ideal combination to achieve the total cracking of tar.

Production of a very low tar content gas is best achieved by cooling the gas to 60-80°C with water and using electrostatic precipitators to capture any aerosols. However, this approach collects water condensed from the gas during cooling, resulting in a waste water heavily contaminated with dissolved organic substances, which require appropriate treatment and/or disposal.

Trace impurities

The removal of N,S,Cl and other trace elements volatilized from the biomass during gasification is usually required for the most end users of the gas. Nitrogen compounds are mainly as ammonia, with some hydrogen cyanide being possible and can't be removed by filtration but require wet scrubbing with water or aqueous solutions, which cools the gas to about 50 °C. The

Renewable Energy

alternative to wet scrubbing is to leave the N compounds and to use low-NO_x techniques during combustion, or selective catalytic reduction of the nitrogen oxides in the flue gas.

Chlorine content in the biomass is present usually as HCl in the gas from the gasifier, the concentration depending on the feed stock and gasification conditions. The removal of HCl is typically undertaken by wet scrubbing or absorption on active materials such as CaO/MgO.

The alkali components in the biomass particularly, Na and K compounds, are volatiles at high temperatures but it is uncertain which compounds are actually present in the gas. The alkali compounds cause corrosion of ceramic filters and turbine blades and the best way to reduce the concentration is to cool the gases to about 500 °C to condense the compounds and then filter the gas.

Lecture- 10

Principles of Pyrolysis

Pyrolysis

Pyrolysis is the one of the most common methods in thermal conversion technology of biomass. In pyrolysis, biomass is heated to moderate temperatures, 400-600°C, In the absence of stoichiometric oxygen to produce oil that can be used as a feed stock in existing petroleum refineries. This is a high throughput process that has a potential for requiring relatively low capital investment. In gasification, biomass is heated to high temperatures, >700°C, to produce a synthesis gas(H₂ and CO), which can be converted in a catalytic step to liquid transportation fuels(mixed alcohols, Fishcher-Tropsch fuels, methanol –to-gasoline etc.).

This technology builds upon decades of experience with gasification of coal. Both approaches have the potential advantages of being relatively insensitive to feedstock type, both suffer from production of unwanted byproducts. In pyrolysis, oxygen-containing compounds (aldehydes, ketones, phenolics and organic acids) make the oil too unstable and acidic for introduction into existing pipelines, tankers and refineries.

Biomass pyrolysis techniques

Depending on the operating conditions, the pyrolysis process can be divided into three sub classes. Conventional slow pyrolysis, fast pyrolysis and flash pyrolysis. The range of important operating parameters for pyrolysis processes is given in the following table. At present, the preferred technology is fast or flash pyrolysis at high temperature with very short residence time.

Main operating parameters for pyrolysis process

Operating parameters	Slow pyrolysis	Fast pyrolysis	Flash pyrolysis
Pyrolysis temperature (°C)	300-700	600-1000	800-1000
Heating Rate(°C/Sec)	0.1-1	10-200	>1000
Particle size (mm)	5-50	<1	<0.2
Solid residence time (Sec)	300-550	0.5-10	<0.5

Pyrolysis processes

Slow pyrolysis

Slow pyrolysis is a conventional pyrolysis process whereby the heating rate is kept slow (approximately 0.1-1 °C/s). This slow heating rate leads to higher char yield than the liquid and gaseous products. Slow pyrolysis has been utilized for thousands of years primarily for the production of charcoal. In slow wood pyrolysis, biomass is heated to ~500 °C. the vapour residence time in the reactor, gas-phase products have ample opportunities to continue to react with other products to form char.

Fast Pyrolysis

Fast pyrolysis uses much faster heating rates (about 10-200°C) and is considered as a better process than slow pyrolysis for producing liquid or gases. In fast pyrolysis the liquid product yield is higher since the fast heating rates allow the conversion of thermally unstable biomass compounds to a liquid product before they form undesired coke. Typically, fast pyrolysis processes produce 60-75 wt% of liquid bio oil, 15-20%wt of solid char and 10-20 %wt of non-condensable gases depending on the feed stock used. Fast pyrolysis occurs on the timescale of a few seconds or less. Therefore, chemical reaction kinetics, heat and mass transfer processes and phase transition phenomena play important role in product distributions. Among pilot scale reactors, fluidized bed reactors are best suited for the process as they offer high heating rates, rapid devolatilization and are easy to operate. Other reactors such as entrained flow reactors, circulating fluidized bed reactors, rotating cone reactors etc. are also used for this purpose.

Flash pyrolysis

Flash pyrolysis is an improved version of fast pyrolysis, whereby the heating rates are very high, >1000°C/s, with reaction times of few to several seconds. Present reactors for flash pyrolysis include fluidized bed reactors, vacuum pyrolysis reactor, rotating cone reactor, entrained flow reactor, ablative, vortex or blade, twin screw reactors. Entrained flow or fluidized bed reactors are considered the best reactors for this purpose. Due to the rapid heating rates and short reaction

times, for better yields, this process requires smaller particle size compared to the other processes.

Types of biomass pyrolysis reactors

Small-scale pyrolysis devices for fundamental research

1. Resistively heated micro-furnace or tube pyrolyzer

Micro furnaces provide a constantly heated isothermal pyrolysis zone into which samples are introduced by a liquid syringe, solid plunger syringe, or in a little cup. Lack of control of the temperature/time characteristics of the sample has made the continuous-mode pyrolyzer less attractive for precise analytical work. However, the combination of a pulsed molecular beam source with the continuous mode pyrolysis oven overcomes these control problems.

2. Resistively heated element pyrolyser

Filament pyrolyzers can acquire a controlled pyrolysis temperature extremely quickly. An initial pulse of heating at high voltage produces a current through the metal filament causing it to heat rapidly until the programmed pyrolysis temperature is achieved. The pyrolysis temperature is maintained by reducing the voltage. The filament pyrolyzer such as a Pt-coil pyrolyzer appears to be the mostly used among various commercial models of the pyrolysis reactors. Samples that are soluble in a volatile solvent are pyrolysed using a ribbon probe. Those that are not heated using a coil probe. While samples are added directly on to the ribbon probe, quartz tubes are used to hold the samples before being inserted into the coil probe with regards to the later, the exact pyrolysis reaction time is difficult to determine since the sample never come in to direct contact with the filament.

3. Curie-point filament pyrolyzer

Curie point pyrolyzer utilizes ferro-magnetic metals to provide rapid and reproducible heating conditions. The sample is positions on to the end of pyrolysis wire made from an appropriate ferro-magnetic alloy. It is then inserted the pyrolyzer and rapidly heated using a high frequency induction coil. The temperature ceases to rise when the curie-point of the metal has been

reached. That is the exact reproducible temperature at which ferro-magnetic material loses its magnetism. At this point the temperature remains constant until the coil is switched off. In contrast to the micro furnace, the rise time of curie-point pyrolyzer is much faster. However, the choice of different pyrolysis temperatures is limited since they are determined by the curie point of available materials.

4.Laser pyrolyzer

The Laser pyrolyser consists of a laser and the associated optical devices , the sample chamber and cold trap. The laser is focused through microscope objective lense and the targeted area is pyrolysed using either a continuous wave or a number of high energy pulses. The thermal interaction between laser and material initiates a shock which in turn produce a range of pyrolysis products. A variety of different laser can be used as a fragmentation source depending on the type of material being pyrolysed. Lasers used for pyrolysis include Nd:YAG laser (1064nm), an rogan ion laser(458-515 nm)and a ArF eximer laser(193nm) to name a few. The use of laser as a fragmentation source has several advantages. Unlike the filament, curie-point and the furnace pyrolyzer, laser pyrolysis requires the very little sample preparation or pre-treatment since analysis is performed directly on the solid polymer matter. The intense, short duration laser beam enables rapid temperature rise times, followed by rapid cooling, reducing the potential for secondary reactions between the pyrolysis products and thereby simplifying interpretations of fragmentation patterns. finally, the collimated nature of the laser beam enables focusing to achieve spatial resolutions in targeting specific areas and layers of the sample.

5.Plasma pyrolysis reactor.

Plasma pyrolysis reactor offers some unique advantages for biomass conversion, in comparison to conventional pyrolysis at low temperatures and slow heating rates. The high energy density and temperature associated with thermal plasmas and the corresponding fast reaction times provide a potential solution for the problems that occur in conventional pyrolysis processes, such as low gas productivity and the generation of heavy tarry compounds. Nevertheless, plasma pyrolysis of biomass for energy and chemical production are seldom studied because of the high electrical power consumption. In fact, the temperature initiated in thermal plasma (usually 2500-9500 °C) is much too high for biomass pyrolysis. Recently there was an study which resulted that

this type of plasma combines the high plasma reactivity and thermal efficiency with a medium temperature (900-9500°C) and favours hydrocarbon cracking and thus increase the yield of syngas. This method is therefore practical interest for the utilization of biomass material for the purpose of syngas and char production.

Pilot scale pyrolysis reactors

1. Fixed Bed Reactor

Fixed bed reactors were traditionally used for the production of charcoal. Poor and slow heat transfer resulted in very low liquid charcoal yields. These gasifiers are divided into downdraft and updraft fixed bed reactors. Their technology is simple, reliable and proven for fuels with a relative uniform size. In a down draft fixed bed reactor, solid moves slowly down and a vertical shaft and air introduced and reacts at a throat that supports the gasifying biomass. The solid and product gas move downward in a co-current mode. A relatively clean gas is produced with low tar and usually with high carbon conversion. In contrast, the updraft fixed bed reactor is characterized by solid moving down a vertical shaft and contacting a counter-current mode. The product gas is very dirty with high levels of tars although tar crackers have been developed to alleviate this problem.

2. Bubbling Fluidized Bed Reactor

Bubbling fluidized beds, biomass particles are introduced into a bed of hot sand fluidized by a recirculated product gas. The high heat transfer rates from fluidized sand cause rapid heating of biomass particles and some ablation by attrition with the sand particles occurs. The bubbling fluidized bed gasifier is characterized good temperature control and high reaction rates. They have greater tolerance to particle size range. They also have higher particulates and more moderate tar levels in product gas tar cracking catalysts can be added to the bed. The bubbling fluidized bed pyrolyzer is characterized by simple construction and operation and is well understood technology. They have good temperature control, limited turn-down capability and provide very efficient heat transfer to biomass particles due to high solid density.

3. Circulating Fluidized Bed Reactor

For circulating fluidized bed reactors, biomass particles are introduced into a circulating fluidized bed of hot sand. The recirculated product gas, sand, and biomass particles move together. The high heat transfer rates from sand ensure rapid heating of biomass particles and ablation is more prevalent than with regular fluidized beds. The circulating fluidized bed gasifier is characterized by all features of the bubbling fluidized bed reactors in addition to higher cost at lower capacity. They are in-bed catalytic processing and circulation of hot solids can cause erosion problems inside the reactor vessel. The circulating fluidized bed pyrolyzer is characterized by good temperature control in the reactor. the residence time for the char is almost the same as for vapour and gas. the char is attrited more due to higher gas velocities, which result in high char contents. The produced char is typically separated by cyclone.

4. Entrained flow reactor

Entrained flow fast pyrolysis is in principle a simple technology. however, most of the development of these reactors have not been as successful as had been hoped due to poor heat transfer between the hot gas and soil particles. This reactor can result in very high heating rates of the particles and the residence time can be varied from milli seconds to a few seconds. This gasifier reactor is characterized by a simple design, but costly feed preparation is needed for woody biomass. They require high gas flows in lower liquid yields.

5. Vacuum Furnace Reactor

For this reactor, biomass is thermally decomposed under reduced pressure. The vapours produced are quickly removed from the vacuum and recovered as bio-oil as condensation. This pyrolysis reactor is characterized by longer residence time of solid and short residence times. Other important feature in this reactor includes ability to produce larger particles than most fast pyrolysis reactors and there is less char in the liquid product due to lower gas velocities. There is also no requirement for carrier gas and the process is mechanically complicated. The typical liquid yields for dry biomass feed obtained in this process are from 35 to 50%.

6. Ablative Reactor

The ablative reactor is characterized by high velocity impact of particle on a hot reactor wall, achieved by centrifugal force or mechanically. High relative motion is achieved between

Renewable Energy

particles and the reactor wall which is typically less than 600 °C. The system is more intensive and the process is mechanically driven so the reactor is so complex.

The ablative pyrolysis reactors have considerable advantages over conventional fluidized bed reactors,

1. No milling of the biomass is required, because the heat introduced as the particles are pyrolysed as by the direct contact with the hot surface.
2. They have good heat transfer with high heating rates and relatively small contact surface because compact design.
3. They have high energy and cost efficiency as no heating and cooling of fluidizing gases is required.
4. They allow installation of condensation units with a small volume, requiring less space at lower costs.

7. Rotating Cone Reactor

The rotating cone reactor is a novel reactor type for flash pyrolysis of biomass with negligible char formation, in which rapid heating and a short residence time of the solids can be realized. Biomass materials like wood, rice husks or even olive stones can be pulverized and fed to the rotating cone reactor. Carrier gas requirements in the pyrolysis reactor are much less than for fluid bed and transported bed systems. However, gas is needed for char burn off and for sand transport. Complex integrated operations of three subsystems are required: Rotating cone pyrolyzer, riser for sand recycling, and bubbling char combustor. Like other shallow transported-bed reactors relatively fine particles are required to obtain a good liquid yield. The liquid yields of 60-70% on dry feed are typically obtained. There is no large scale commercial implementation.

8. Auger Reactor

In an auger reactor, hot sand and biomass particles are fed at one end of a screw. The screw mixes the sand and biomass and conveys them along, providing a good control of the biomass residence time. This process does not dilute the pyrolysis products with a carrier or fluidizing

Renewable Energy

gas. However, sand must be reheated in a separate vessel and mechanical reliability is a concern. There is no large scale commercial implementation. The advantage of this reactor include,

- Compact size
- No carrier gas required
- Lower processing temperatures (400°C)

The challenges in this are,

1. Presence of moving parts in the hot zone,
2. Heat transfer at a large scale may be a problem.

Lecture –11

Biogas technology

Energy Conversion routes – Biochemical conversion method – biogas – principle

Biomass is organic material made from plants and animals. Biomass contains stored energy from the sun. Plants absorb the sun's energy in a process called photosynthesis. The chemical energy in plants gets passed on to animals and people that eat them. Biomass is a renewable energy source because we can always grow more trees and crops, and waste will always exist. Some examples of biomass fuels are wood, crops, manure, and some garbage.

When burned, the chemical energy in biomass is released as heat. If you have a fireplace, the wood you burn in it is a biomass fuel. Wood waste or garbage can be burned to produce steam for making electricity, or to provide heat to industries and homes.

Burning biomass is not the only way to release its energy. Biomass can be converted to other usable forms of energy like methane gas or transportation fuels like ethanol and biodiesel. Methane gas is the main ingredient of natural gas. Smelly stuff, like rotting garbage, and agricultural and human waste, release methane gas - also called "landfill gas" or "biogas." Crops like corn and sugar cane can be fermented to produce the transportation fuel, ethanol. Biodiesel, another transportation fuel, can be produced from left-over food products like vegetable oils and animal fats.

Typical biomass supply is derived from:

- Woody forest residue, fuelwood, mill residues, short rotation crops,
- Non-woody agricultural crops, crop residue, processing residues; and
- Animal waste such as manure from feed lots and municipal sewage and waste.

.Biomass energy – Direct and indirect uses

Renewable Energy

Biomass energy can be used directly or indirectly. Firewood is a common example of direct use by combustion. But biomass energy can be transformed into other forms of fuel. Ethanol from agricultural crops such as sugar cane and methane from manure and sewage are examples of indirect use fuel. Ethanol from agricultural crops such as sugar cane and methane from manure and sewage are examples of indirect use.

Biomass energy – conversion

Biomass energy in the forms of gas can occur spontaneously, as marshgas, or landfill gas for example, but alcohols do not. Agricultural wastes or manures undergo certain processes first.

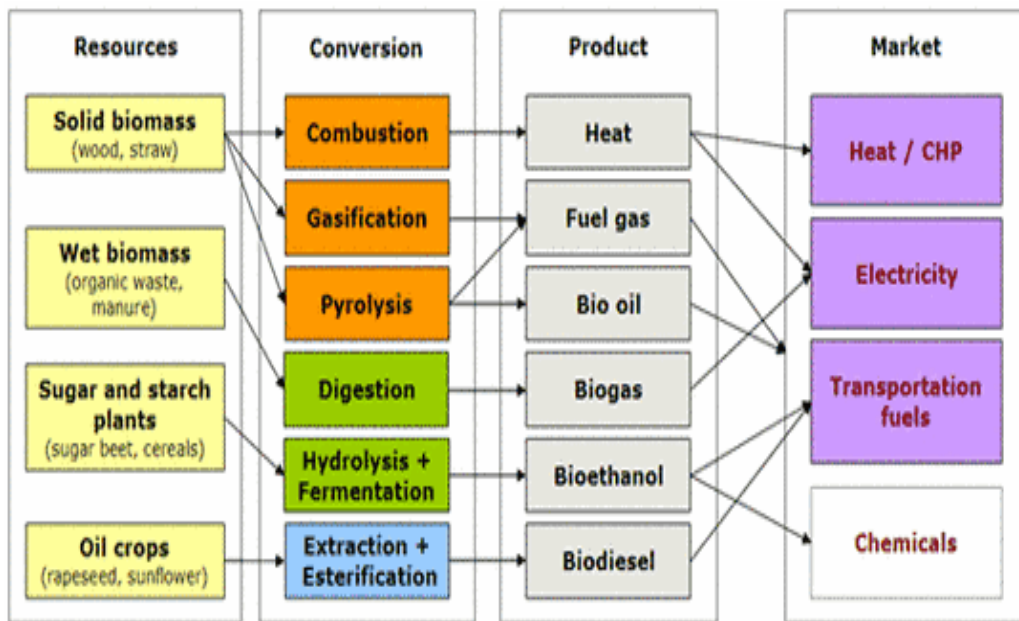

The two main processes are thermal and biological

Thermal and biological biomass energy conversion

Thermal conversion can happen in three ways

- Combustion, (including co-firing - mixed coal/biomass combustion)

Renewable Energy

- Woodchips
- Pyrolysis and,
- Gasification

Combustion of course means that biomass is burned, similar to coal and oil, to make electricity. When mixing biomass with coal, this co-firing process is very efficient. Solid municipal waste is also burned to generate electricity.

Pyrolysis is a chemical process of decomposition of biomass materials. It is a heating process without the involvement of oxygen. The recycling of used vehicle tyres uses pyrolysis.

Gasification involves processes that turn parts of solid biomass materials into gas. Pyrolysis can do this for example.

Biological conversion can happen through

Digestion and fermentation of biodegradable wastes occurs in large digester power plants where bacteria convert waste into gas. The produced gas drives turbines that generate electricity from these wastes. The solids that are left behind may be used as fertilizer, depending on the biomass materials used.

Biofuels that can be made from biomass are

- Biogas
- Bioethanol
- Biobutanol and
- Biodiesel

Biogas

Biogas can be captured from marshes, from landfill or wastes such as sewage, and burned to produce electricity. It can also be generated intentionally through anaerobic composting. When refined it can be used to power vehicles directly.

Renewable Energy

Biogas, a mixture containing 55-65 percent methane, 30-40 percent carbon dioxide and the rest being the impurities (H_2 , H_2S , and some N_2), can be produced from the decomposition of animal, plant and human waste. It is a clean but slow burning gas and usually has a calorific value-between 5000 to 5500 kcal/kg. It can be used directly in cooking, reducing the demand for firewood. Moreover, the material from which the biogas is produced retains its value as a fertilizer and can be returned to the soil. Biogas has been popular on the name, "Gobar Gas" mainly because cow dung has been the material for its production, hitherto. It is not only the excreta of the cattle, but also the piggery Waste as well as poultry droppings are very effectively used for biogas generation. A few other materials through which biogas can be generated are algae, crop residues (agro-wastes), garbage kitchen wastes, paper wastes, sea wood, human waste, waste from sugarcane refinery, water hyacinth etc., apart from the abovementioned animal wastes. Any cellulosic organic material of animal or plant origin, which is easily biodegradable, is a potential raw material suitable for biogas production.

Biogas is produced by digestion, pyrolysis, or hydrogasification. "Digestion biological process that occurs in the absence of, oxygen and in the presence of anaerobic organisms at ambient pressures and temperatures of 35-70°C. The container in which this digestion takes place is know as the digester

Stages of anaerobic digestion in methane production

Formerly, methane fermentation was hypothetically designed as a two-step process including an acid forming stage followed by a methane forming stage. However, with the exception of methanol, acetate and formate, methanogenic bacteria cannot metabolize alcohols and organic acids.

The current scheme represents a three-stage process in which three groups of bacteria are involved.

- a. Hydrolytic and acidogenic bacteria
- b. Acetogenic bacteria

c. Methanogenic bacteria

Fig : Microbial groups involved in the conversion of biomass to methane

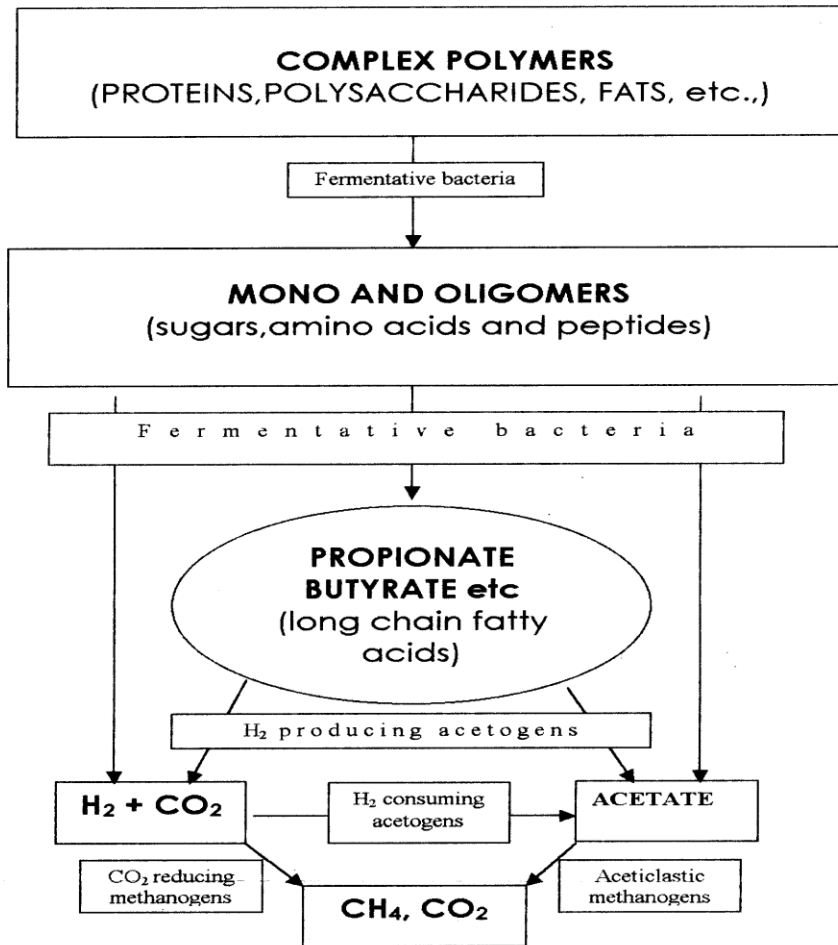

Manure Collection

Livestock facilities use manure management systems to collect and store manure because of sanitary, environmental, and farm operational considerations. Manure is collected and stored as liquids, slurries, semi-solids, or solids.

Raw Manure. Manure is excreted with a solids content of 8 to 25 percent, depending upon animal type. It can be diluted by various process waters or thickened by air drying or by adding bedding materials.

Liquid Manure. Manure handled as a liquid has been diluted to a solids content of less than 5 percent. This manure is typically “flushed” from where it is excreted, using fresh or recycled water. The manure and flush water can be pumped to treatment and storage tanks, ponds, lagoons, or other suitable structures before land application. Liquid manure systems may be adapted for biogas production and energy recovery in “warm” climates. In colder climates, biogas recovery can be used, but is usually limited to gas flaring for odor control.

Slurry Manure. Manure handled as slurry has been diluted to a solids content of about 5 to 10 percent. Slurry manure is usually collected by a mechanical “scraper” system. This manure can be pumped, and is often treated or stored in tanks, ponds, or lagoons prior to land application. Some amount of water is generally mixed with the manure to create a slurry. For example, spilled drinking water mixes with pig manure to create a slurry. Manure managed in this manner may be used for biogas recovery and energy production, depending on climate and dilution factors.

Semi-Solid Manure. Manure handled as a semi-solid has a solids content of 10 to 20 percent. This manure is typically scraped. Water is not added to the manure, and the manure is typically stored until it is spread on local fields. Fresh scraped manure (less than one week old) can be used for biogas and energy production in all climates, because it can be heated to promote bacterial growth.

Solid Manure. Manure with a solids content of greater than 20 percent is handled as a solid by a scoop loader. Aged solid manure or manure that is left “unmanaged” (i.e., is left in the pasture where it is deposited by the animals) or allowed to dry is not suitable for biogas recovery.

Effluent Storage

The products of the anaerobic digestion of manure in digesters are biogas and effluent. The effluent is a stabilized organic solution that has value as a fertilizer and other potential uses. Waste storage facilities are required to store treated effluent because the nutrients in the effluent cannot be applied to land and crops year round.

The size of the storage facility and storage period must be adequate to meet farm requirements during the non-growing season. Facilities with longer storage periods allow

flexibility in managing the waste to accommodate weather changes, equipment availability and breakdown, and overall operation management.

Gas Handling

A gas handling system removes biogas from the digester and transports it to the end-use, such as an engine or flange. Gas handling includes: piping; gas pump or blower; gas meter; pressure regulator; and condensate drain(s).

Biogas produced in the digester is trapped under an airtight cover placed over the digester. The biogas is removed by pulling a slight vacuum on the collection pipe (e.g., by connecting a gas pump/blower to the end of the pipe), which draws the collected gas from under the cover. A gas meter is used to monitor the gas flow rate. Sometimes a gas scrubber is needed to clean or “scrub” the biogas of corrosive compounds contained in the biogas (e.g., hydrogen sulfide). Warm biogas cools as it travels through the piping and water vapor in the gas condenses. A condensate drain(s) removes the condensate produced.

Gas Use

Recovered biogas can be utilized in a variety of ways. The recovered gas is 60 - 80 percent methane, with a heating value of approximately 600 - 800 Btu/ft³. Gas of this quality can be used to generate electricity; it may be used as fuel for a boiler, space heater, or refrigeration equipment; or it may be directly combusted as a cooking and lighting fuel.

Electricity can be generated for on-farm use or for sale to the local electric power grid. The most common technology for generating electricity is an internal combustion engine with a generator. The predicted gas flow rate and the operating plan are used to size the electricity generation equipment.

Engine-generator sets are available in many sizes. Some brands have a long history of reliable operation when fueled by biogas. Electricity generated in this manner can replace energy purchased from the local utility, or can be sold directly to the local electricity supply system. In addition, waste heat from these engines can provide heating or hot water for farm use.

Renewable Energy

Biogas can also be used directly on-site as a fuel for facility operations. Equipment that normally uses propane or natural gas can be modified to use bio- gas. Such equipment includes boilers, heaters, and chillers.

- **Boilers and Space Heaters.** Boilers and space heaters fired with biogas produce heat for use in the facility operations. Although this may not be the most efficient use of the gas, in some situations it may be a farm's best option.
- **Chilling/Refrigeration.** Dairy farms use considerable amounts of energy for refrigeration. Approximately 15 to 30 percent of a dairy's electricity load is used to cool milk. Gas-fired chillers are commercially available and can be used for this purpose. For some dairies, this may be the most cost effective option for biogas utilization.

Other energy use options may exist. For example, a nearby greenhouse could be heated with the biogas, and carbon dioxide from the heater exhaust could be used to enhance plant growth. These options need to be evaluated on a case-by-case basis.

Benefits of Biogas Technology

Most confined livestock operations handle manure as liquids, slurries, semi-solids, or solids that are stored in lagoons, concrete basins, tanks, and other containment structures. These structures are typically designed to comply with local and state environmental regulations and are a necessary cost of production.

Biogas technology can be a cost-effective, environment and neighborhood friendly addition to existing manure management strategies. Biogas technologies anaerobically digest manure, resulting in biogas and a liquefied, low-odor effluent. By managing the anaerobic digestion of manure, biogas technologies significantly reduce Biochemical Oxygen Demand (BOD), and pathogen levels; remove most noxious odors; and convert most of the organic nitrogen to plant available inorganic nitrogen.

The principal reasons a farmer or producer would consider installing biogas systems are:

- **On-Site Farm Energy.** By recovering biogas and producing on-farm energy, livestock producers can reduce monthly energy purchases from electric and gas suppliers.

Renewable Energy

- **Reduced Odors.** Biogas systems reduce offensive odors from overloaded or improperly managed manure storage facilities. These odors impair air quality and may be a nuisance to nearby communities. Biogas systems reduce these offensive odors because the volatile organic acids, the odor causing compounds, are consumed by biogas producing bacteria.
- **High Quality Fertilizer.** In the process of anaerobic digestion, the organic nitrogen in the manure is largely converted to ammonium. Ammonium is the primary constituent of commercial fertilizer, which is readily available and utilized by plants.
- **Reduced Surface and Groundwater Contamination.** Digester effluent is a more uniform and predictable product than untreated manure. The higher ammonium content allows better crop utilization and the physical properties allow easier land application. Properly applied, digester effluent reduces the likelihood of surface or groundwater pollution.
- **Pathogen Reduction.** Heated digesters reduce pathogen populations dramatically in a few days. Lagoon digesters isolate pathogens and allow pathogen kill and die-off prior to entering storage for land application.

Biogas recovery can improve profitability while improving environmental quality. Maximizing farm resources in such a manner may prove essential to remain competitive and environmentally sustainable in today's livestock industry. In addition, more widespread use of biogas technology will create jobs related to the design, operation, and manufacture of energy recovery systems and lead to the advancement of U.S. agribusiness.

Lecture-12

Biogas plants types

Most organic materials undergo a natural anaerobic digestion in the presence of moisture and absence of oxygen and produce biogas. The biogas so obtained is a mixture of methane (CH₄): 55-65% and Carbon dioxide (CO₂): 30-40%. The biogas contains traces of H₂, H₂S and N₂. The calorific value of biogas ranges from 5000 to 5500 Kcal/Kg (18.8 to 26.4 MJ /m³). The biogas can be upgraded to synthetic natural gas (SNG) by removing CO₂ and H₂S. The production of biogas is of particular significance in India because of its large scale cattle production. The biogas is used for cooking, domestic lighting and heating, run I.C. Engines and generation of electricity for use in agriculture and rural industry. Family biogas plants usually of 2-3 m³ capacity.

Advantages

- The initial investment is low for the construction of biogas plant.
- The technology is very suitable for rural areas.
- Biogas is locally generated and can be easily distributed for domestic use.
- Biogas reduces the rural poor from dependence on traditional fuel sources, which lead to deforestation.
- The use of biogas in village helps in improving the sanitary condition and checks environmental pollution.
- The by-products like nitrogen rich manure can be used with advantage.
- Biogas reduces the drudgery of women and lowers incidence of eye and lung diseases.

Raw materials for biogas generation Biogas is produced mainly from

- Cow dung
- Sewage
- Crop residues
- Vegetable wastes
- Water hyacinth

Renewable Energy

- Poultry droppings
- Pig manure

Digestion is biological process that occurs in the absence of oxygen and in the presence of anaerobic organisms at temperatures (35-70°C) and atmospheric pressure. The container in which, this process takes place is known as digester.

Anaerobic digestion:

The treatment of any slurry or sludge containing a large amount of organic matter utilizing bacteria and other organisms under anaerobic condition is commonly referred as anaerobic digestion or digestion. Anaerobic digestion consists of the following three stages. The three stages are (i) the enzymatic hydrolysis, (ii) acid formation and (iii) methane formation.

Enzymatic hydrolysis

In this stage, a group of facultative microorganisms acts upon the organic matter and convert insoluble, complex, high molecular compounds of biomass into simple, soluble, low molecular compounds. The organic substances such as polysaccharide, protein and lipid are converted into mono-saccharide, peptide, amino acids, and fatty acids. Then they are further converted into acetate, propionate and butyrate.

Acid formation

The micro organisms of facultative and anaerobic group collectively called as acid formers, hydrolyze and ferment the productions of first phase i.e., water soluble substances into volatile acid. The major component of the volatile acid is the acetic acid. In addition to acetate or hydrogen and carbon dioxide, some other acids like butyric acid and propionic acid are also produced.

Methane formation

Finally, acetate or hydrogen plus carbon dioxide are converted into gas mixture of methane (CH₄) and CO₂ by the bacteria, which are strictly anaerobes. These bacteria are called methane fermentators. For efficient digestion, these acid formers and methane fermentators must remain

in a state of dynamic equilibrium. The remaining indigestible matter is referred as “slurry”. The following are some approximate rules used for sizing biogas plants or for estimating their performance:

1. One kg of dry cattle dung produces approximately 1 m³ of biogas.
2. One kg of fresh cattle dung contains 8% dry biodegradable mass.
3. One kg of fresh cattle dung has a volume of about 0.9 liters.
4. One kg of fresh cattle dung requires an equal volume of water for preparing slurry.
5. Typical retention time of slurry in a biogas plant is 40 days.

The efficiency of biogas generation depends upon the following factors:

- a. Acid formers and methane fermenters must remain in a state of dynamic equilibrium, which can be achieved by proper design of digester.
- b. Anaerobic fermentation of raw cow dung can take place at any temperature between 8 and 55°C. The value of 35°C is taken as optimum. The rate of biogas formation is very slow at 8°C. For anaerobic digestion, temperature variation should not be more than 2 to 3°C. Methane bacteria work best in the temperature range of 35 and 38°C.
- c. A pH value between 6.8 and 7.8 must be maintained for best fermentation and normal gas production. The pH above 8.5 should not be used as it is difficult for the bacteria to survive above this pH.
- d. A specific ratio of carbon to nitrogen (C/N ratio) must be maintained between 25:1 and 30:1 depending upon the raw material used. The ratio of 30:1 is taken as optimum.
- e. The water content should be around 90% of the weight of the total contents. Anaerobic fermentation of cow dung proceeds well if the slurry contains 8 to 9% solid organic matter.
- f. The slurry should be agitated to improve the gas yield.
- g. Loading rate should be optimum. If digester is loaded with too much raw material, acids will accumulate and fermentation will be affected.

Types of biogas plants: Biogas plants basically are two types.

Floating dome type

Eg. KVIC-type (KVIC- Khadi Village Industries Commission)

Fixed dome type

Eg. Deenabandu model

KVIC type biogas plant

This mainly consists of a digester or pit for fermentation and a floating drum for the collection of gas. Digester is 3.5-6.5 m in depth and 1.2 to 1.6 m in diameter. There is a partition wall in the center, which divides the digester vertically and submerges in the slurry when it is full. The digester is connected to the inlet and outlet by two pipes. Through the inlet, the dung is mixed with water (4:5) and loaded into the digester. The fermented material will flow out through outlet pipe. The outlet is generally connected to a compost pit. The gas generation takes place slowly and in two stages. In the first stage, the complex, organic substances contained in the waste are acted upon by a certain kind of bacteria, called acid formers and broken up into small-chain simple acids. In the second stage, these acids are acted upon by another kind of bacteria, called methane formers and produce methane and carbon dioxide.

Gas holder

The gas holder is a drum constructed of mild steel sheets. This is cylindrical in shape with concave top. The top is supported radially with angular iron. The holder fits into the digester like a stopper. It sinks into the slurry due to its own weight and rests upon the ring constructed for this purpose. When gas is generated the holder rises and floats freely on the surface of slurry. A central guide pipe is provided to prevent the holder from tilting. The holder also acts as a seal for the gas. The gas pressure varies between 7 and 9 cm of water column. Under shallow water table conditions, the adopted diameter of digester is more and depth is reduced. The cost of drum is about 40% of total cost of plant. It requires periodical maintenance. The unit cost of KVIC model with a capacity of 2 m³/day costs approximately Rs.14, 000 - 00. Fig. 1. Schematic diagram of a KVIC biogas plant

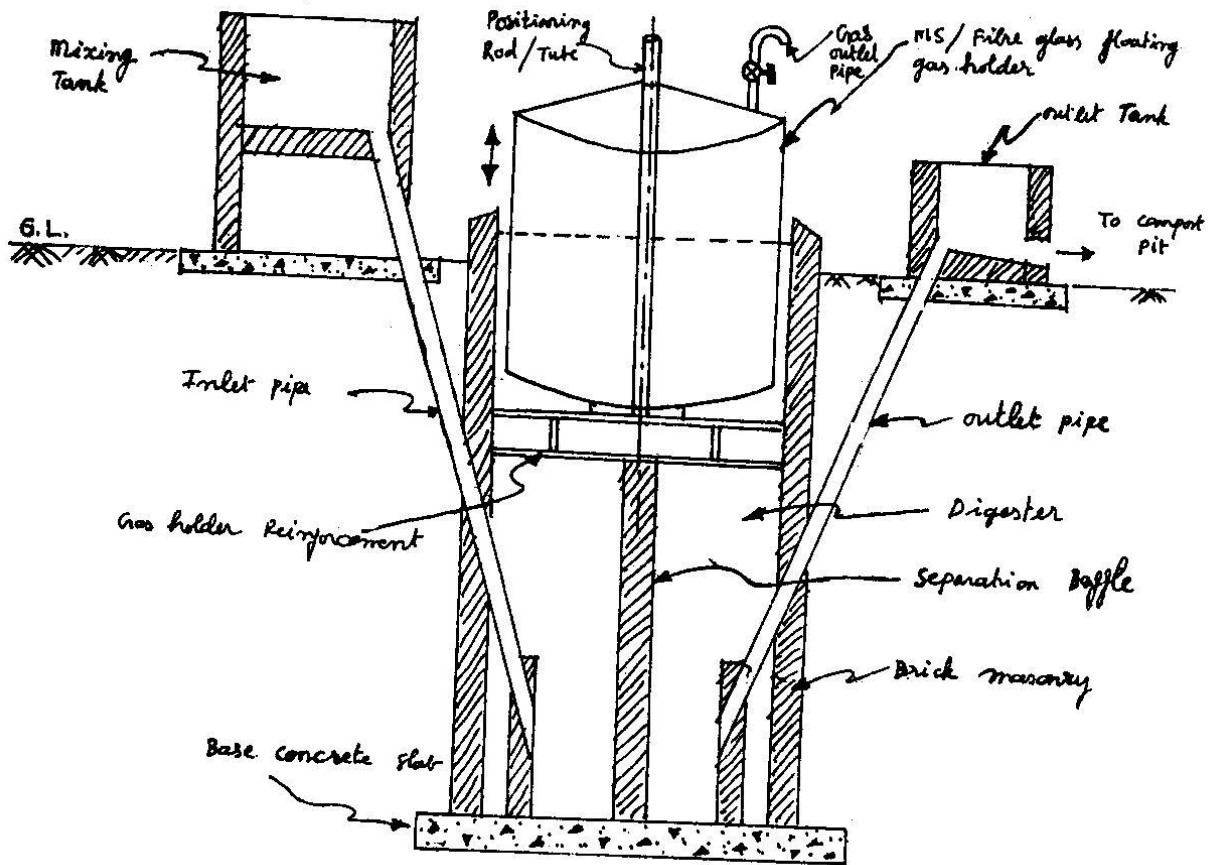

Schematic diagram of a KVIC biogas plant

Janata type biogas plant:

The design of this plant is of Chinese origin but it has been introduced under the name “Janata biogas plant” by Gobar Gas Research Station, Ajitmal in view of its reduced cost. This is a plant where no steel is used, there is no moving part in it and maintenance cost is low. The plant can be constructed by village mason taking some pre-explained precautions and using all the indigenously available building materials. Good quality of bricks and cement should be used to avoid the afterward structural problems like cracking of the dome and leakage of gas. This model have a higher capacity when compared with KVIC model, hence it can be used as a community biogas plant. This design has longer life than KVIC models. Substrates other than cattle dung such as municipal waste and plant residues can also be used in janata type plants. The plant consists of an underground well sort of digester made of bricks and cement having a dome shaped roof which remains below the ground level is shown in figure. At almost middle of the

digester, there are two rectangular openings facing each other and coming up to a little above the ground level, act as an inlet and outlet of the plant. Dome shaped roof is fitted with a pipe at its top which is the gas outlet of the plant. The principle of gas production is same as that of KVIC model. The biogas is collected in the restricted space of the fixed dome, hence the pressure of gas is much higher, which is around 90 cm of water column.

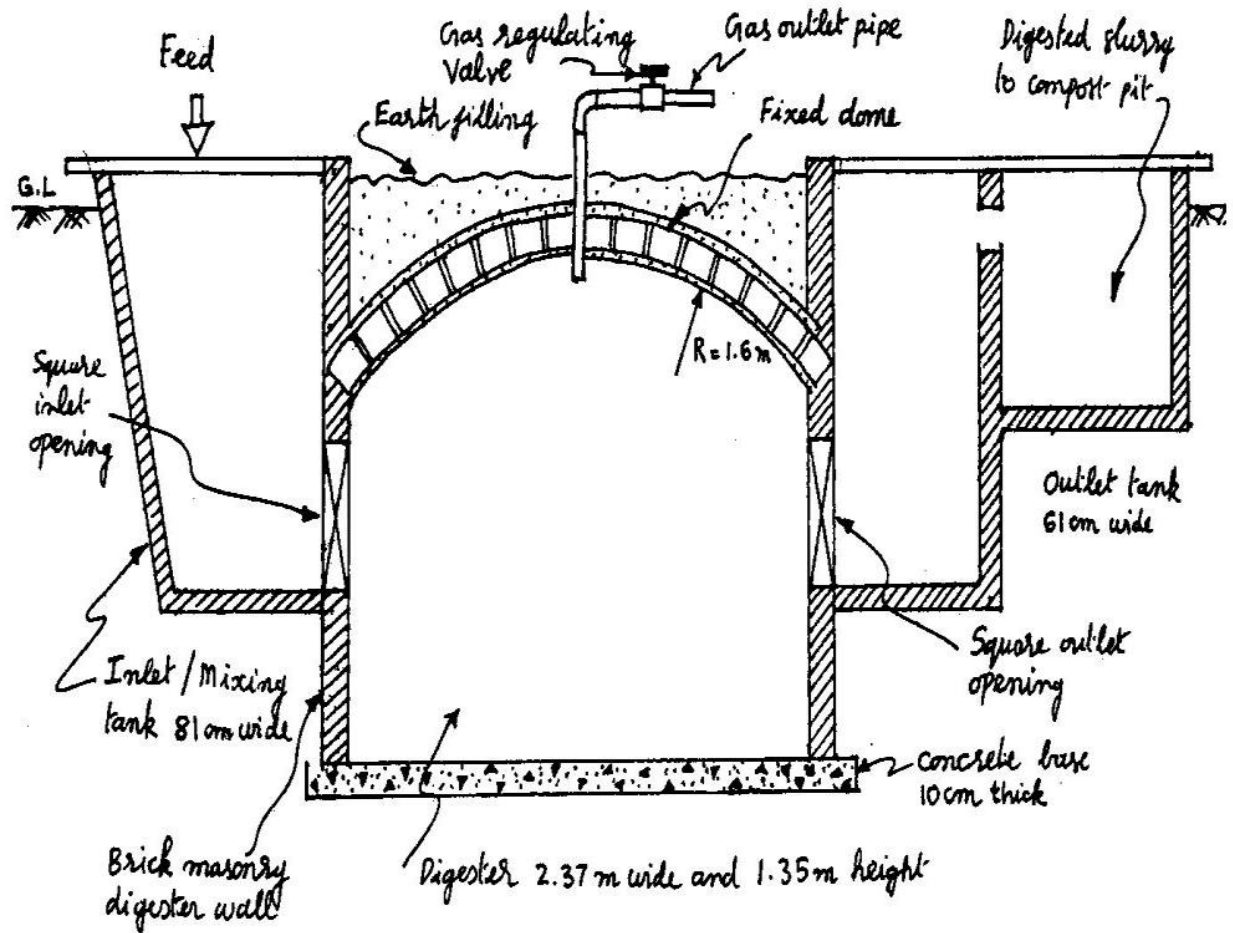

Deenbandhu biogas plant :

Deenbandhu model was developed in 1984, by Action for Food Production (AFPRO), a voluntary organization based in New Delhi. Schematic diagram of a Deenabandhu biogas plant entire biogas programme of India as it reduced the cost of the plant half of that of KVIC model and brought biogas technology within the reach of even the poorer sections of the population.

Renewable Energy

The cost reduction has been achieved by minimizing the surface area through joining the segments of two spheres of different diameters at their bases. The cost of a Deenbandhu plant having a capacity of 2 m³/day is about Rs.8000-00. The Deenbandhu biogas plant has a hemispherical fixed-dome type of gas holder, unlike the floating dome of the KVIC-design is shown. The dome is made from pre-fabricated ferrocement or reinforced concrete and attached to the digester, which has a curved bottom. The slurry is fed from a mixing tank through an inlet pipe connected to the digester. After fermentation, the biogas collects in the space under the dome. It is taken out for use through a pipe connected to the top of the dome, while the sludge, which is a by-product, comes out through an opening in the side of the digester. About 90 percent of the biogas plants in India are of the Deenbandhu type.

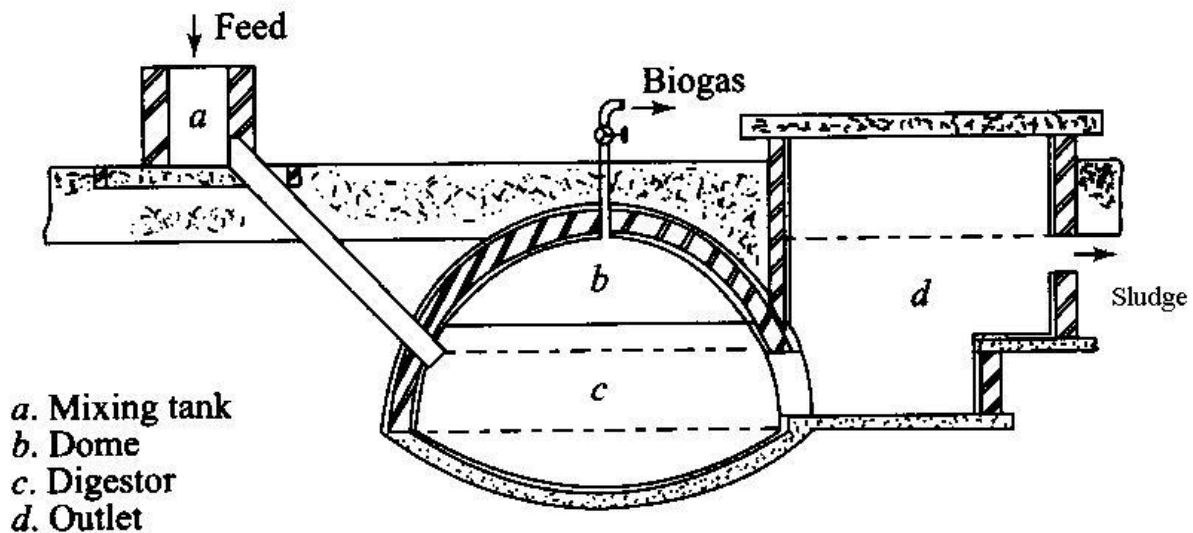

Schematic diagram of a Deenabandhu biogas plant

Lecture 13

Introduction to Biogas Technology

Biogas

It's a mixture of gas produced by the microorganisms during the anaerobic fermentation of biodegradable materials. Anaerobic fermentation is a biochemical process in which particular kinds of bacteria digest biomass in an oxygen-free environment resulting in production of CH₄, CO₂, H₂ and traces of other gases along with decomposed mass.

Properties of Biogas

Biogas is a mixture of different components and the composition varies depending upon the characteristics of feed materials, amount of degradation, etc. Biogas predominantly consists of 50 to 70 per cent methane, 30 to 40 per cent carbon dioxide and low amount of other gases. Methane is a combustible gas. The energy content of biogas depends on the amount of methane it contains. Methane content varies from about 50 percent to 70 percent. The composition and the properties of the biogas are given in the following table 1.1 and 1.2.

Table 1.1 Composition of biogas

Name of the gas	Composition in biogas (%)
Methane (CH ₄)	50-70
Carbon dioxide (CO ₂)	30-40
Hydrogen (H ₂)	5-10
Nitrogen (N ₂)	1-2
Water vapour (H ₂ O)	0.3
Hydrogen sulphide (H ₂ S)	Traces

Table 1.2 Properties of biogas

Properties	Range
Net calorific value (MJ/m ³)	20
Air required for combustion (m ³ /m ³)	5.7
Ignition temperature (°C)	700
Density (kg/m ³)	0.94

Microbiology of biogas production:

The production of biogas from organic material under anaerobic condition involves sequence of microbial reactions. During the process complex organic molecule present in the biomass are broken down to sugar, alcohols, pesticides and amino acids by acid producing bacteria. The resultant products are then used to produce methane by another category of bacteria. The biogas production process involves three stages namely:

- i. Hydrolysis
- ii. Acid formation and
- iii. Methane formation

The process of degradation of organic material in every step is done by range of bacteria, which are specialized in reduction of intermediate products formed. The different process involved in production of biogas is given in the figure. The efficiency of the digestion depends how far the digestion happens in these three stages. Better the digestion, shorter the retention time and efficient gas production.

Hydrolysis

The complex organic molecules like fats, starches and proteins which are water insoluble contained in cellulosic biomass are broken down into simple compounds with the help of enzymes secreted by bacteria. This stage is also known as polymer breakdown stage (polymer to monomer). The major end product is glucose which is a simple product.

Acid formation

The resultant product (monomers) obtained in hydrolysis stage serve as input for acid formation stage bacteria. Products produced in previous stage are fermented under anaerobic conditions to form different acids. The major products produced at the end of this stage are acetic acid, propionic acid, butyric acid and ethanol.

Methane formation:

The acetic acid produced in the previous stages is converted into methane and carbon dioxide by a group of microorganism called "*Methanogens*". In other words, it is process of production of methane by methanogens. They are obligatory anaerobic and very sensitive to environmental changes. Methanogens utilise the intermediate products of the preceding stages and convert them into methane, carbon dioxide, and water. It is these components that make up the majority of the biogas emitted from the system. Methanogenesis is sensitive to both high and low pH's and occurs between pH 6.5 and pH 8. Major reactions occurring in this stage is given below:

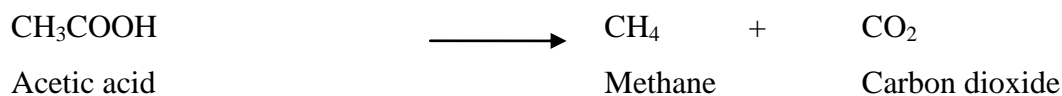

Renewable Energy

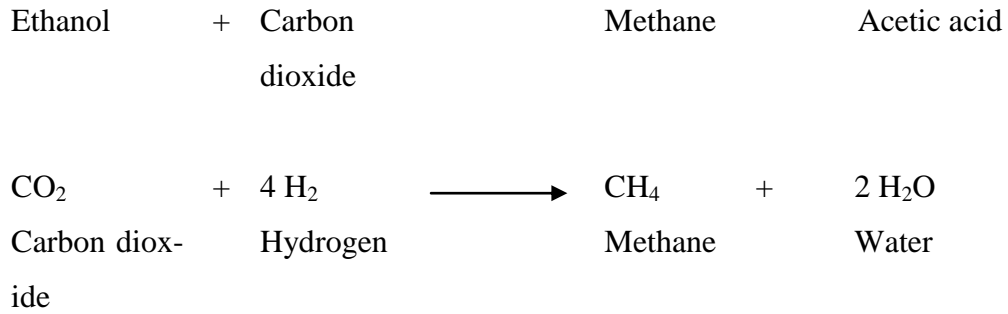

The process of biogas formation through different stages is depicted in figure.

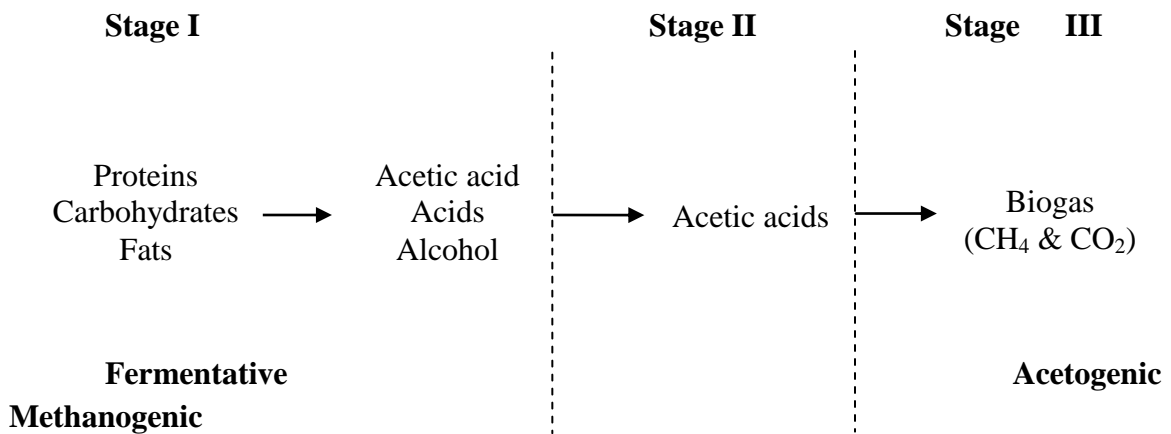

Figure: Stages of biogas formation

Biogas plant and its components:

A physical structure designed to carry out anaerobic digestion of organic materials is called “Biogas plant”. Following are the components of biogas plants:

- Mixing tank : Cow dung is collected from the shed and mixed with the water in equal proportion (1:1) to make a homogenous mixture (slurry) in the mixing tank
- Feed inlet pipe/tank : The homogenous slurry is let into the digester through this inlet pipe (KVIC biogas plants)/tank (Janatha biogas plants)
- Digester : The fed slurry is subjected to anaerobic fermentation with the help of microorganisms inside the digester.
- Gas holder : As a result of anaerobic fermentation, gas produced is stored in gas holder (Drum in the case of KVIC and in dome in the case of fixed dome biogas plants)
- Slurry outlet tank/pipe : The digested slurry is let out from the digester through slurry outlet pipe (KVIC biogas plants)/tank (Janatha biogas plants)
- Gas outlet pipe : Stored gas is released and conveyed through the gas outlet pipe present at the top of gas holder.

Classification of biogas plants

Based on the nature of feeding, biogas plants would be broadly divided into 3 types and they are as follows

- i. **Batch type:** The organic waste materials to be digested under anaerobic condition are charged only once into a reactor-digester. The feeding is between intervals, the plant is emptied once the process of digestion is complete. Retention time usually varies from 30 to 50 days. The gas production in it is intermittent. These plants are well suited for fibrous materials. This type of plant needs addition of fermented slurry to start the digestion process and it not economical to maintain which are considered to be the major draw backs.
- ii. **Semi continuous:** A predetermined quantity of feed material mixed with water is charged into the digester from one side at specified interval of time; (say once a day) and the digested material (effluent) equivalent to the volume of the feed, flows out of the digester from the other side (outlet).

- iii. **Continuous type:** The feed material is continuously charged to the digester with simultaneous discharge of the digested material (effluent). The main features of this type of plants are continuous gas production, requires small digestion area, lesser period for digestion, less maintenance, etc.

The biogas plants used in the villages are of semi continuous type employing animal dung and other biomass as the feed stock for biogas production. So the classification of semi-continuous type biogas plant is explained below.

- i. Floating drum type – KVIC model
- ii. Fixed dome type model – Deenbandhu model

Floating drum type (Constant pressure)

In this type of plants digester is made of bricks and is of circular in shape. It is constructed typically underground to lessen the heat loss from the plant. Partition wall is constructed (dividing the digester into two parts) for higher size capacity plants to avoid the short-circuiting of digested slurry with the fresh feed. Separate gasholder is fabricated and fixed to store the gas produced during digestion besides acting as an anaerobic seal for the process. As the volume of gas production increases drum starts to rise and if the stored gas is withdrawn the level of drum drops to lower level. Scum formed in the digester can be broken with the help of drum rotation both clockwise and anticlockwise. Central guide frame is provided to hold the gasholder and to allow it to move vertically during gas production. The drum is made up of mild steel and it constitutes around 60 per cent of overall plant costs. Salient features of this type of plants include weight of drum helps to discharge the gas produced at constant pressure, volume of gas storage can be judged visually.

Small masonry tanks are constructed for mixing of cow dung, water and to discharge the slurry out of the digester. Concrete pipes are provided to convey the raw and digested slurry in and out of the digester. Gas outlet pipe is provided at top of the drum to let the gas out of drum. KVIC floating drum model is predominantly used in India and fig shows the schematic diagram of it.

Advantages and disadvantages of floating drum plant.

Advantages:

- i. Higher gas production per cum of the digester volume is achieved.
- ii. Floating drum has welded braces, which help in breaking the scum by rotation.
- iii. No problem of gas leakage.

- iv. Constant gas pressure.

Disadvantages

- i. It has higher cost, as cost is dependent on steel and cement
- ii. Heat is lost through the metal gasholder.
- iii. Gasholder required painting once or twice a year, depending on the humidity of the location.
- iv. Flexible pipe joining the gasholder to the main gas pipe requires maintenance, as ultraviolet rays in the sun damage it.

Fixed dome biogas plants (Constant volume)

To reduce the cost of biogas plants, researchers has designed fixed dome plants in which dome act as gasholder in place of high cost drum. Gasholder and digester constructed as single unit. The digesters of such plants are completely underground to maintain a perfect environment for anaerobic fermentation to take place besides avoiding cracking of dome due to difference in temperature and moisture.

Janatha Biogas Plants

Developed exclusively in India completely masonry structure. Provision of Inlet and outlet of raw and digested slurry is constructed in the form of tank. Slurry fed is allowed to undergo anaerobic fermentation in the digester. Gas produced as a result rises up and gets collected in the dome. As the pressure of gas stored in the dome increases, it pushes up the slurry down and causes the slurry level to increase both in inlet and outlet tanks. These levels drop down when the gas in the dome is used up. This displacement provides necessary pressure to push the gas up to the usage point. The pressure coming out of the dome is of variable type as constant in the case of floating drum type. Volume of gas stored in the plant is equal to the total volume of slurry displaced both in inlet and outlet tanks. Fig shows the janatha biogas plant model.

Deenbandhu Biogas Plants

One of the outstanding designs of biogas plants in Indian biogas development program is Deenbandhu biogas plant design. It is improved version of Janatha biogas plant model. Action for food production (AFPRO), a voluntary organization based in New Delhi, developed this model in 1984. This is constructed with locally available materials and the plant demand skillful manpower for construction. Important considerations for design modification are reduction in the overall construction cost, elimination of the loss of biogas through inlet chamber and maximum utilization of digester volume to make the operational HRT close to the designed HRT.

It is constructed by joining the two spheres of different diameters at their bases, thus reducing the cost of bricks used in construction of digester wall. Bottom part of the plant is designed as a segment of sphere, whereas the top portion as hemisphere. In this plant feedstock is fed through concrete pipes and the digested slurry is taken out the digester through tank. As a precaution to avoid the entry of slurry through gas outlet pipe, outlet opening is constructed 150 mm lower than the bottom of gas outlet pipe. Gas holding capacity is 33 per cent of total capacity of the plant. Studies proved that the cost of deenbandhu is 30 and 45 per cent less than that of Janatha and KVIC biogas plants. Fig shows the schematic diagram of deenbandhu biogas plant model.

Advantages

- i. It has low cost compare to floating drum type, as it uses only cement and no steel.
- ii. It has non-corrosion trouble.
- iii. It this type heat insulation is better as construction is beneath the ground.
- iv. Temperature will be constant.
- v. Cattle and human excreta and long fibrous stalks can be fed.
- vi. No maintenance.

Disadvantages:

- i. This type of plant needs the services of skilled masons, who are rather scarce in rural areas.
- ii. Gas production per cum of the digester volume is also less.
- iii. Scum formation is a problem as no stirring arrangement
- iv. It has variable gas pressure

Factors involved in biogas production

Biogas production involves different physical, chemical and biological process for conversion of biodegradable organic materials to energy rich gas.

C/N ratio

The ratio of carbon to nitrogen present in the feed material is called C:N ratio. It is a crucial factor in maintaining perfect environment for digestion. Carbon is used for energy and nitrogen for building the cell structure. Optimum condition for anaerobic digestion to take place ranges from 20 to 30:1. This means the bacteria use up carbon about 20 to 30 times faster than they use up nitrogen.

When there is too much carbon in the raw wastes, nitrogen will be used up first and carbon left over. This will make the digestion slow down and eventually stops. On

the other hand if there is too much nitrogen, the carbon soon becomes exhausted and fermentation stops. The nitrogen left over will combine with hydrogen to form ammonia. This can kill or inhibit the growth of bacteria specially the methane producers.

Temperature

Temperature affects the rate of reaction happening inside the digester. Increase in the ambient temperature increases the rate of reaction thus increasing the biogas production as well. Methane bacteria work best at a temperature of $35^{\circ} - 38^{\circ} \text{C}$. The fall in gas production starts at 20°C and stops at a temperature of 10°C . Studies showed that 2.25 m^3 of gas was produced from 4.25 m^3 of cattle dung everyday when the digester temperature was 25°C . When the temperature rose to 28.3°C the gas production was increased by 50 per cent to 3.75 m^3 per day.

Retention time

It is the theoretical time that particular volume of feedstock remains in the digester. In other words, retention time describes the length of time the material is subjected to the anaerobic reaction. It is calculated as the volume of digester divided by the feedstock added per day and it is expressed in days. Under anaerobic condition, the decomposition of the organic substances is slow and hence need to keep for long time to complete the digestion. In case of Indian digesters, where the feed stock is diluted with equal composition, so demarcation prevails between solid and liquid. In this case, biomass in the form of bacteria is washed out; hence the solid retention time (SRT) is equal to hydraulic retention time (HRT).

Loading rate

Loading rate is defined as the amount of raw material fed to the digester per day per unit volume. If the reactor is overloaded, acid accumulation will be more obviously affecting daily gas production. On the other hand, under loading of digester have negative impact in designed gas production.

Toxicity

Though small quantities of mineral ions like sodium, potassium stimulates the growth of bacteria, the high concentration of heavy metals and detergents have negative impact in gas production rate. Detergents like soap, antibiotics, and organic solvents are toxic to the growth of microbes inside the digester. Addition of these substances along with the feed stock should be avoided.

pH or hydrogen ion concentration

To maintain a constant supply of gas, it is necessary to maintain a suitable pH range in the digester. pH of the slurry changes at various stages of the

digestion. In the initial acid formation stage in the fermentation process, the pH is around 6 or less and much of CO₂ is given off. In the latter 2-3 weeks times, the pH increase as the volatile acid and N₂ compounds are digested and CH₄ is produced. The digester is usually buffered if the pH is maintained between 6.5 and 7.5. In this pH range, the micro – organisms will be very active and digestion will be very efficient. If the pH range is between 4 and 6 it is called acidic. If it is between 9 and 10 it is called alkaline. Both these are detrimental to the methanogenic (Methane production) organisms.

Total solid content

The raw cow dung contains 80-82% of moisture. The balance 18-20% is termed as total solids. The cow dung is mixed usually in the proportion of 1:1 in order to bring the total solid content to 8-10%. This adjustment of total solid content helps in digesting the materials at the faster rate and also in deciding the mixing of the various crop residues as feed stocks in biogas digester.

Feed rate

One of the prerequisites of good digestion is the uniform feeding of the digester so that the micro – organisms are kept in a relatively constant organic solids concentration at all times. Therefore the digester must be fed at the same time everyday with a balanced feed on the same quality and quantity.

Diameter to depth ratio

Studies reveal that gas production per unit volume of digester capacity was maximum, when the diameter to depth ratio was in the range of 0.66 to 1.00. One reason may be that because in a simple unstirred single stage digester the temperature varies at different depths. The most activity digesting sludge is in the lower half of the digester and this is less affected by changes in night and day temperature.

Nutrients

The major nutrients required by the bacteria in the digester are, C, H₂, O₂, N₂, P and S, of these nutrients N₂ and P are always in short supply and therefore to maintain proper balance of nutrients an extra raw material rich in phosphorus (night soil, chopped leguminous plants) should be added along with the cow dung to obtain maximum production of gas.

Degree of mixing

Bacteria in the digester have very limited reach to their food, it is necessary that the slurry is properly mixed and bacteria get their food supply. It is

found that slight mixing improves the fermentation, however a violent slurry agitation retards the digestion.

Type of feed stocks

All plant and animal wastes may be used as the feed materials for a digester. When feed stock is woody or contains more of lignin, then digestion becomes difficult. To obtain as efficient digestion, these feed stocks are combined in proportions. Pre-digestion and finely chopping will be helpful in the case of some materials. Animal wastes are predigested. Plant wastes do not need pre-digestion. Excessive plant material may choke the digester.

Uses of biogas

Biogas serves as a suitable alternate fuel for satisfying the energy needs of human society. It can be used for production of power, for cooking, lighting, etc. Figure explains the flow chart of different applications of biogas.

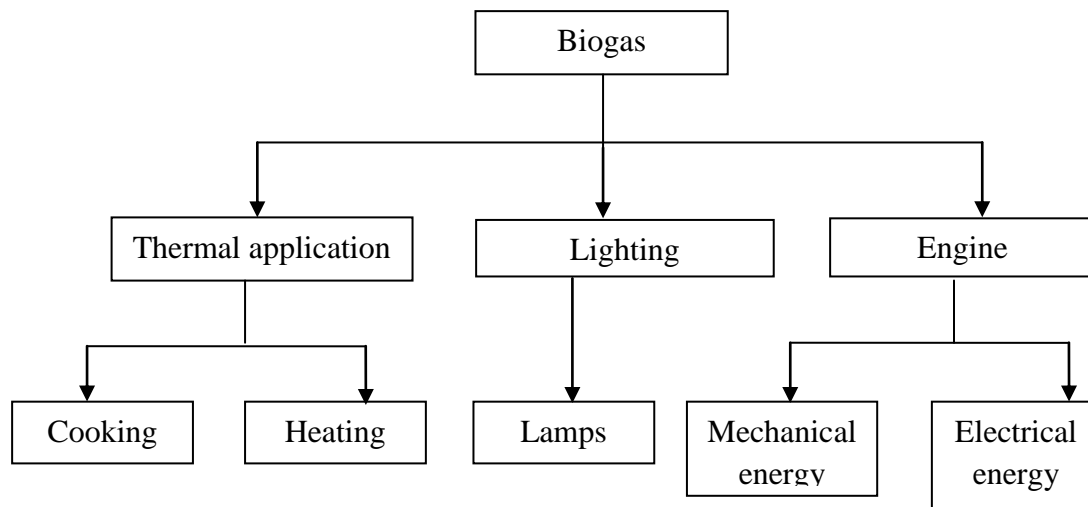

Fig. Applications of biogas

- ***Cooking and lighting***

The primary domestic uses of biogas are cooking and lighting. Because biogas has different properties from other commonly used gases, such as propane and butane, and is only available at low pressures (4 - 8 cm water), stoves capable of burning biogas efficiently must be specially designed. Biogas burns with blue flame and without any soot and odour which is considered to be one of the major advantage compared to traditional cooking fuel like firewood and cow dung cake.

Lighting can be provided by means of a gas mantle, or by generating electricity. Biogas mantle lamps consume 2-3 cft per hour having illumination capacity equivalent to 40 W electric bulbs at 220 volts. This application is predominant in rural and unelectrified areas.

- ***Biogas as an Engine Fuel***

Biogas can be used as a fuel in stationary and mobile engines, to supply motive power, pump water, drive machinery (e.g., threshers, grinders) or generate electricity. It can be used to operate four stroke diesel and spark ignition engines. Electricity generation using biogas is a commercially available and proven technology. Typical installations use spark-ignited propane engines that have been modified to operate on biogas. Biogas-fueled engines could also be used for other on-farm applications. As discussed below, diesel or gasoline engines can be modified to use biogas.

IC engines (typically used for electricity generation) can be converted to burn treated biogas by modifying carburetion to accommodate the lower volumetric heating value of the biogas into the engine and by adjusting the timing on the spark to accommodate the slower flame velocity of biogas ignition systems. When biogas is used to fuel such engines, it may be necessary to reduce the hydrogen sulphide content if it is more than 2 percent otherwise the presence will lead to corrosion of engine parts.

In terms of electricity production, small internal combustion engines with generator can be used to produce electricity in the rural areas with clustered dwellings thus promoting decentralized form of electricity avoiding grid losses.

- ***Use of biogas as vehicular fuel***

Biogas is suitable as a fuel for most purposes, without processing. If it is to be used to power vehicles, however, the presence of CO₂ is unsatisfactory, for a number of reasons. It lowers the power output from the engine, takes up space in the storage cylinders (thereby reducing the range of the vehicle), and it can cause problems of freezing at valves and metering points, where the compressed gas expands, during running, refuelling, as well as in the compression and storage procedure. All, or most, of the CO₂ must therefore be removed from the raw biogas, to prepare it for use as fuel for vehicles, in addition to the compression of the gas into high-pressure cylinders, carried by the vehicle.

Uses of biodigested slurry

The slurry after the digestion will be washed out of the digester which is rich in various plant nutrients such as nitrogen, phosphorous and potash. Well-fermented biogas slurry improves the physical, chemical and biological properties of the soil resulting qualitative as well as quantitative yield of food crops. Slurry from the biogas plant is more than a soil conditioner, which builds good soil texture, provides and releases plant nutrients. Since there are no more parasites and pathogens in the slurry, it is highly recommended for use in farming. The economic value of the slurry shows that investment can be gained back in three to four year's time if slurry is properly used.

The cow dung slurry after digestion inside the digester comes out with following characteristics and has following advantages:

- When fully digested, effluent is odourless and does not attract insects or flies in the open condition.
- The effluent repels termites whereas raw dung attracts them and they can harm plants fertilised with farmyard manure (FYM).
- Effluent used as fertiliser reduces weed growth with about 50%. When FYM is used the undigested weed seeds cause an increased weed growth.
- It has a greater fertilising value than FYM or fresh dung. The form in which nitrogen available can be easily assimilated by the crops.

Fig. Deenbandhu biogas plant

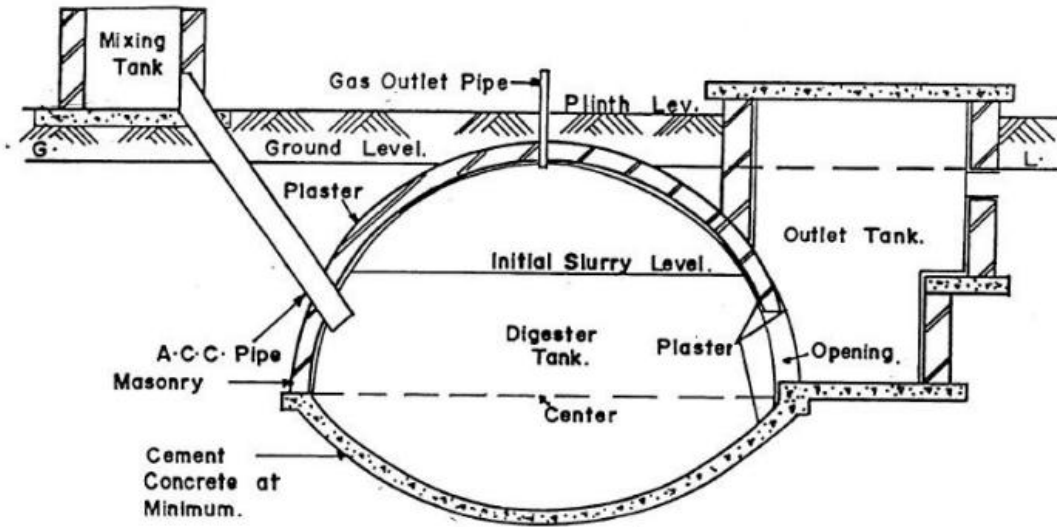
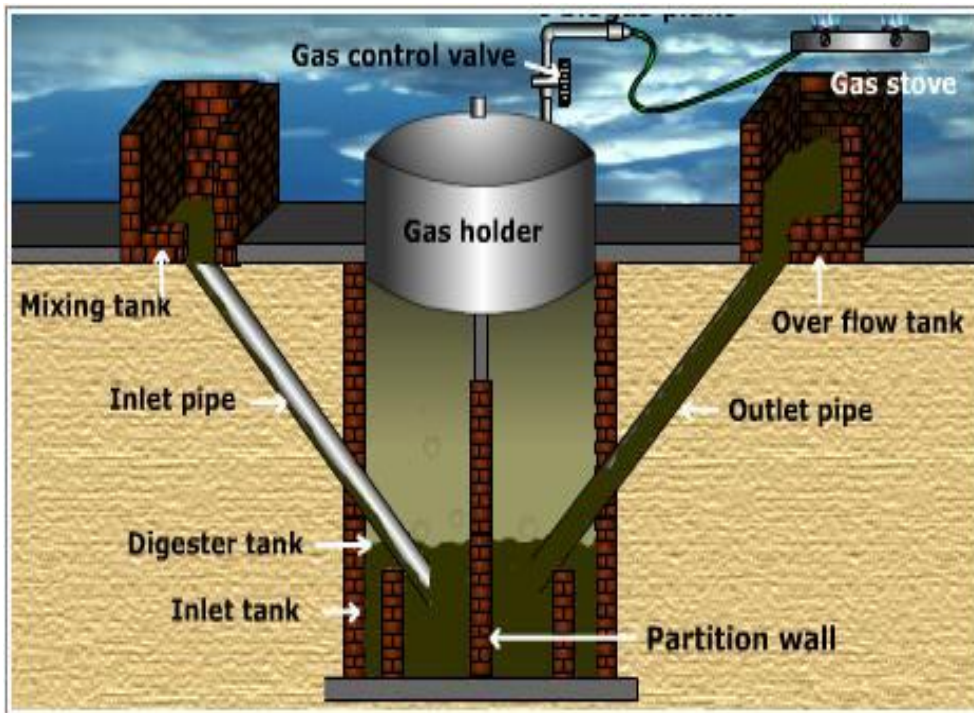

Fig. Floating drum biogas plant



Lecture-14

Size and Site Selection for Biogas plant

Sizing of biogas plant follows based on three parameters namely

- Daily feed,
- Retention time and
- Digester volume

The biogas plant size is dependent on the average daily feed stock and expected hydraulic retention time of the material in the biogas system. Capacity of the plant should be designed based on the availability of raw materials. Capacity of the plant indicates the quantity of gas produced in a day. Based on the study, 1 kg of cow dung along with equal quantity of water (1:1) under anaerobic conditions in a day produces 0.04 m³ or 40 litres of biogas.

Based on the availability of cow dung, the capacity of biogas plant to be constructed can be calculated as follows

Example

- 1 cow will yield an average of 10 kg of cow dung in a day. Assume a house is having 3 cows. Our objective is to calculate the capacity of the plant to be constructed.
- 3 cow x 10 kg/cow/day = 30 kg of cow dung/day 1 kg of cow dung will yield 0.04 m³ or 40 litres of biogas. So 30 kg will produce 30x 40 = 1200 litres or 1.2 m³ of gas in a day. So the capacity of the plant to be constructed will be 1 m³.

Example

To produced 1 m³ of gas in a day, quantity of cow dung required can be calculated as

$$1 \text{ m}^3 / (0.04 \text{ m}^3/\text{kg of cow dung}) = 25 \text{ kg of dung.}$$

When a biogas plant is underfed the gas production will be low; in this case, the pressure of the gas might not be sufficient to fully displace the slurry in the outlet chamber. If too much material is fed into the digester and the volume of gas is consumed, the slurry may enter the gas pipe and to the appliances.

Table shows the quantity of cow dung required for different plant capacities.

Table. Plant size and daily feed stock requirement

Plant Size (m ³)	Daily dung required/day (kg)	Quantity of water required (litres)
1	25	25
2	50	50
3	75	75
4	100	100
6	150	150
8	200	200
10	250	250

Scaling of the digester

The size of the digester i.e. the digester volume is determined by the length of the retention time and by the amount of fermentation slurry supplied daily. The amount of fermentation slurry consists of the feed material (e.g., cattle dung) and the mixing water.

Example

25 kg of cow dung + 25 l water = 50 l fermentation slurry

The digester volume is calculated by the formula

$$\text{Digester volume (l)} = \text{Daily feed (l/day)} \times \text{Retention time (days)}$$

Assuming the Retention time to be 40 days, then the digester volume can be calculated by

$$\text{Digester volume} = 50 \text{ (l/day)} \times 40 \text{ (days)} = 2000 \text{ l or } 2 \text{ m}^3$$

Selection of construction site

Selection of construction sites are mainly governed by the following factors:

- The site should facilitate easy construction works.
- The selected site should be such that the construction cost is minimized
- The selected site should ensure easy operation and maintenance activities like feeding of plant, use of main gas valve, composing and use of slurry, checking of gas leakage, draining condensed water from pipeline etc.
- The site should guarantee plant safety.
- To make plant easier to operate and avoid wastage of raw materials, especially the dung/swine manure, plant must be as close as possible to the cattle shed.
- The site should be in slightly higher elevation than the surrounding. This helps in avoiding water logging. This also ensures free flow of slurry from overflow outlet to the composting pit.
- For effective functioning of bio-digesters, right temperature (20-35°C) has to be maintained inside the digester. Therefore it is better to avoid damp and cool place – Sunny site is preferable.

Renewable Energy

- To mix dung and water or flush swine manure to the digester, considerable quantity of water is required. If water source is far, the burden of fetching water becomes more.
- The well or ground water source should be at least 10 meter away from the biodigester especially the slurry pit to avoid the ground water pollution.
- If longer gas pipe is used the cost will be increased as the conveyance system becomes costly. Furthermore, longer pipeline increases the risk of gas leakage. The main gas valve which is fitted just above the gas holder should be opened and closed before and after the use of biogas. Therefore the plant should be as near to the point of application as possible.
- The site should be at sufficient distance from trees to avoid damage of biodigester from roots.
- Type of soil should have enough bearing capacity to avoid the possibility of sinking of structure.

Location of biogas plant

A biogas plant should not be located further than 5 meters from the field. The digester chamber must be in an open area and should not be near any water source or natural water as animal excrement may seep into underground water. The plant should also be situated on a slope and not on the low land to avoid the danger of floods. The excess manure from expansion chamber should flow into the farmer's field or the storage tank and not into natural water bodies such as rivers to avoid the risk of pollution.

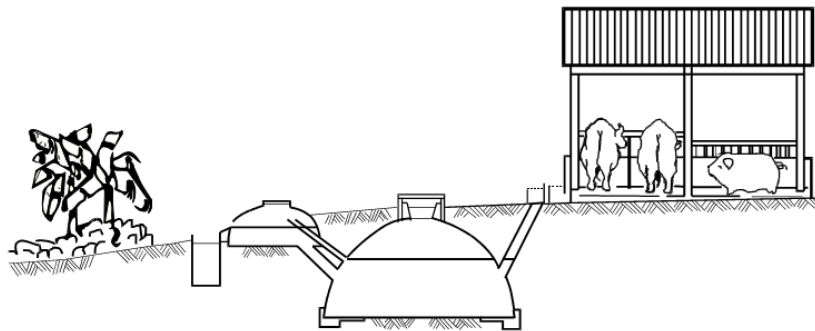

Fig. Location of biogas plant

Lecture-15

Selection of construction materials

If the materials used in the plant construction such as cement, sand, aggregate etc. are not of good quality, the quality of the plant will be poor even if the design and workmanship are excellent. A brief description regarding the specifications for some of the construction materials is provided below to assist with selection of the best quality materials.

Cement

Cement should be high quality Portland cement from a brand with a good reputation. It must be fresh, free from lumps and stored in dry place. Bags of cement should not be stacked directly on the floor or against the walls. Wooden planks have to be placed on the floor to protect cement from dampness. Cement bags should be stalked at least 20 cm away from any walls.

Sand

Sand should be clean and not contain soil or other material; dirty sand will have a very early negative effect to the structure. Coarse and granular sand are suitable for concreting work, however fine sand should be used for plastering works. River/lake sand is well graded hence preferred. Avoid dusty sand.

Gravel/Ballast

The size of gravel should neither be very big nor very small and should be clean, hard and angular in shape. If dirty should be cleaned first before use and the maximum size of gravel should be $\frac{3}{4}$ " or $\frac{1}{4}$ the slab thickness. Gravel should be clean, hard and of angular shape. If it is dirty, it has to be washed properly before use.

Water

Water is mainly required for making the cement mortar for masonry works, concreting works and plastering. It is also used to soak bricks before using. Besides, it is required for cleaning or washing construction materials if they are dirty. The water from ponds or canal may be dirty so it is better not to use it. Dirty water will have an adverse effect on the strength of structure. Water from water tap or well or any other sources that supply clean water has to be used.

Bricks

Brick plays a very important role in construction of biodigesters. Bricks should be of high quality, usually the best quality available in the local market. The bricks should be well burnt, straight, regular in shape, sizes and should not have cracks or broken parts. High

quality bricks make a clear metallic sound when hitting them to each other. Such bricks should be able to bear a pressure of 120 kg per square centimeter. Before use, bricks must be soaked for few minutes in clean water. Wet brick will not absorb water from the mortar which is needed for setting properly.

Mild steel bars

MS bars are used to construct the covers of outlet tank and water drain chamber. It should meet the engineering standard generally adopted. For plants of 4, 6 and 8 cum, MS rods of 8 mm diameter and for plant of 10 cum capacity 10 mm diameter is recommended. MS bar should be free from heavy rust.

Mixing Device

This device is used to prepare good quality water-dung solution in the inlet tank when cattle dung is used as feeding material. Usually for household biogas digesters, vertical mixing devices are installed. The device should be of good quality, as per the design, and the mixing blades have to be well galvanized. The blade should be properly aligned for the effective mixing.

List of materials required for construction of KVIC biogas plants(40 days retention time)

Materials	Plant size (m ³)					
	2	3	4	6	8	10
Bricks- I Class (no)	2460	2770	3210	3730	4430	4650
Cement (50kg) bags (no)	13	17	19	23	26	28
Stone chip(12mm/20mm) (cu.m)	0.60	0.90	0.95	1.25	1.40	1.60
River sand(cu.m)	2.00	2.55	2.90	3.40	4.50	5.00
A.C.Pipe 100 mm dia (m)	3.9	4.6	6.3	6.5	7.7	8.0

**List of materials required for construction of deenbandhu biogas plants
(40 days retention time)**

Materials	Plant size (m ³)				
	1	2	3	4	6
Bricks- I Class (no)	700	1000	1300	1600	2200
Cement (50kg) bags (no)	8	14	16	22	28
Stone chip (12mm/20mm) (cu.m)	0.85	1.14	1.43	1.70	2.40
River sand(cu.m)	0.85	1.11	1.43	1.70	2.40
GI pipe (cm)	17.78	17.78	17.78	17.78	17.78
A.C pipe 6" dia (m)	1.80	1.80	1.80	1.80	1.80
Iron rod 6 mm dia (kg)	6.00	7.00	10.00	12.00	15.00
Labours (man hours)					
Excavation	8	10	14	18	24
Masons	8	11	13	16	22
Construction labours	16	22	26	30	44

Plant layout

Construction works of biodigester starts with the process of layout works. This is the activity carried out to mark the dimensions of plant in the ground to start the digging work. For this purpose, first a small peg has to be stuck in the ground at the centre spot of the digester. Then the following steps should be followed:

- Level the ground and determine the centre line of the digester, outlet tank and inlet pit
- Decide the reference level. It is better to assume the leveled ground level as the reference level. The top of the dome (outer) should exactly be in this level.
- Select the outer radius of the pit (digester diameter plus wall thickness plus space for a footing projection of at least 10 cm) and mark it in the rope or chord.
- Insert a stick or wooden peg in the leveled ground at the centre of the proposed digester pit. With the help of this pole and chord prepared earlier, make a circle, which indicates the area to dig.
- From the centre point where the central line meets with the perimeter line, draw a tangent and measure a length equal to half of the breadth of outlet plus wall thickness (for outlet chamber) and half of the size of manhole (30cm) plus wall thickness for manhole, on either side of this tangent. Mark the manhole ensuring that the inner size is 60 cm x 60 cm.

- Draw horizontal parallel lines from the points in either side in the tangent, which will meet the dome. From the centre point where the central line meets with the perimeter line, measure the length of outlet plus wall thickness to decide the outer dimension of outlet.
- Use coloured powder to mark the dimensions.
- Decide the location of slurry pits while laying out plant digester and outlet.

Digging of Pit

After completion of lay-out work, the work for digging of pit has to be started. Tools like, crow-bar, picks, spade, shovel and basket should be available at the site. The following points have to be followed to dig the pit.

- Digging should be done as per the dimensions fixed during layout
- As far as practical the cutting in ground should be vertical
- If the water table is high and digging to the required depth is difficult, a deeper pit has to be constructed near the digester pit. Water accumulated in the digester pit has to be drain to this pit through underground pipes. Water should be pumped from this pit.
- Once the depth of digging is equal to the dimension, the work of leveling and ramming the base has to be done. The pit bottom must be leveled and the earth must be untouched
- Ensure that the excavated earth is deposited at least 2 m away from the pit in each side to ease the construction works.
- Be careful to avoid accident while digging near the sides as soil may collapse.
- Dig the foundation for the manhole (first step of outlet tank) along with the foundation for digester as per the dimensions in the drawing during the layout.

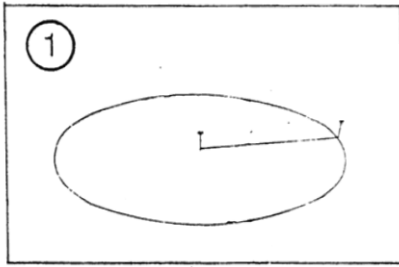

Marking the dimensions for digging



Digging

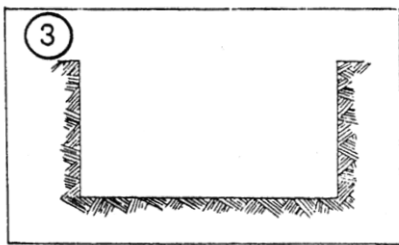

Completed pit

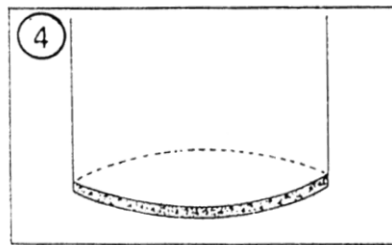

Laying the concrete foundation

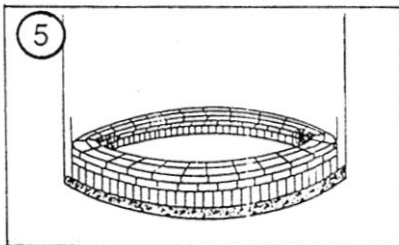

Constructing brick wall

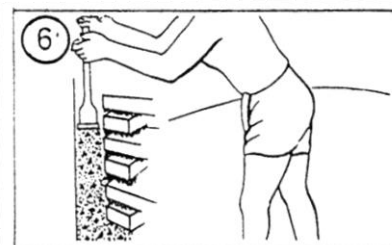

Filling the outer layer

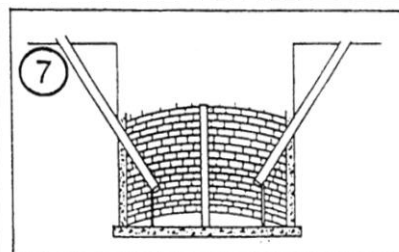

Placing inlet and outlet pipe

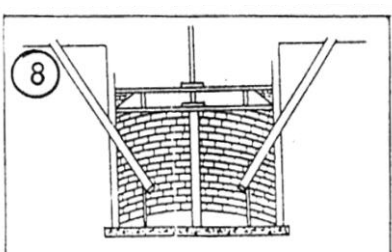

Fixing the guide frame

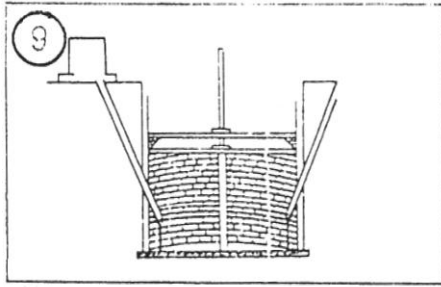

Constructing inlet tank

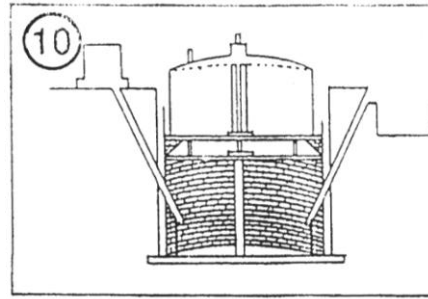

Constructing slurry outlet tank

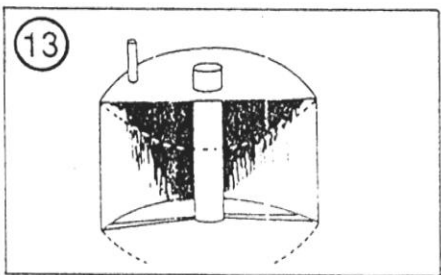
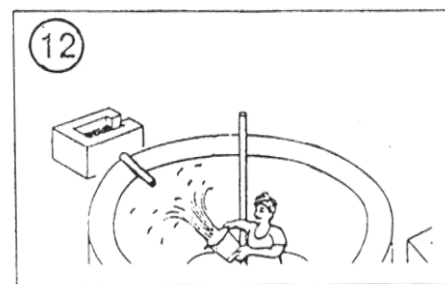
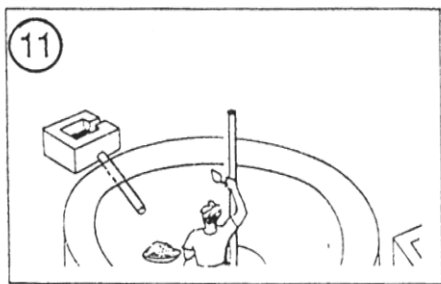

Gas holder

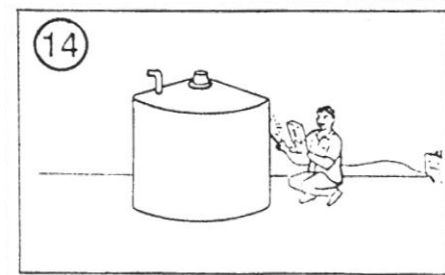

Welding the gas holder

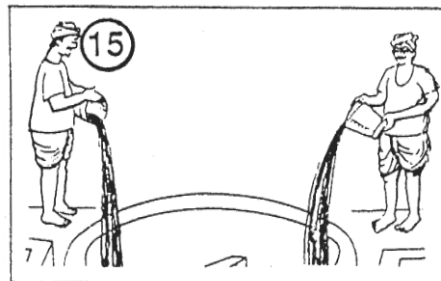

Feeding the plant with fresh slurry

Fig. CONSTRUCTION OF KVIC BIOGAS PLANT

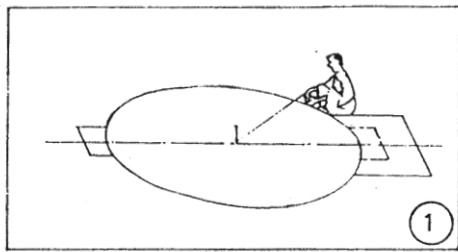

Marking

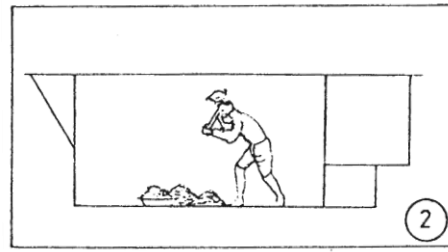

Digging

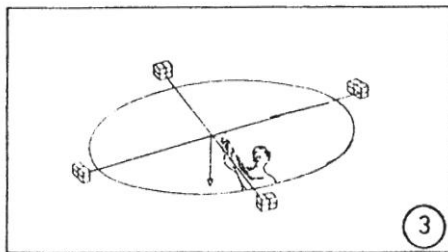

Finding the centre

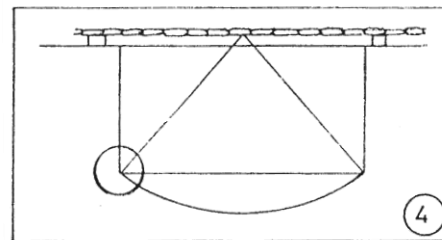

Digging for hemisphere layer

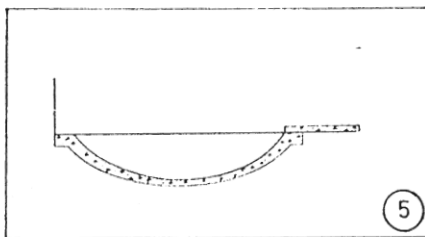

Laying of concrete layer

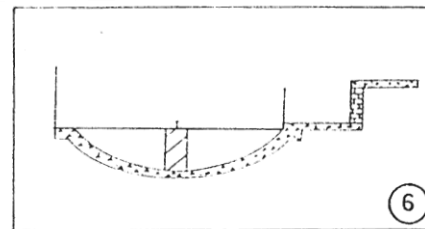

Finding the centre for constructing the dome

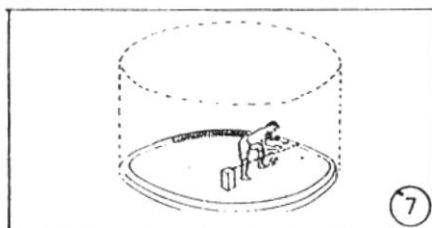

Laying of bricks

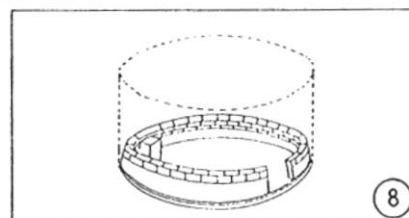

Leaving place for manhole construction

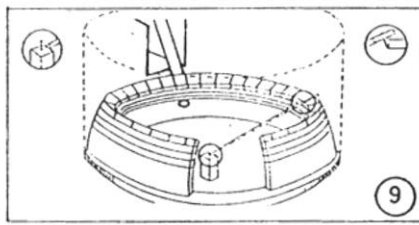

Laying inlet pipe

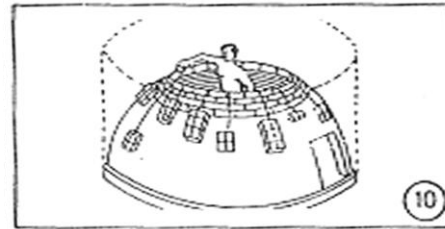

Construction of dome

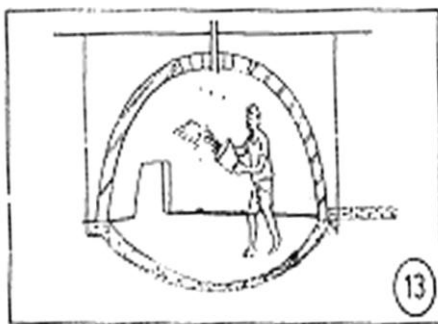
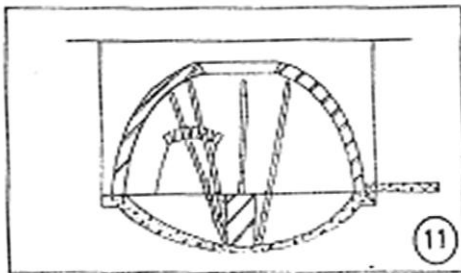

Watering

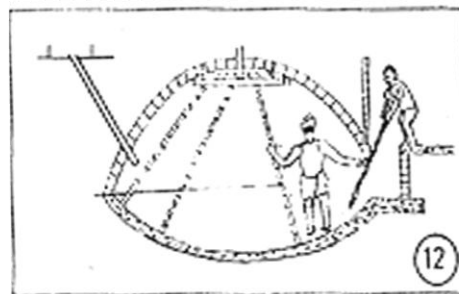

Closing of dome with bricks

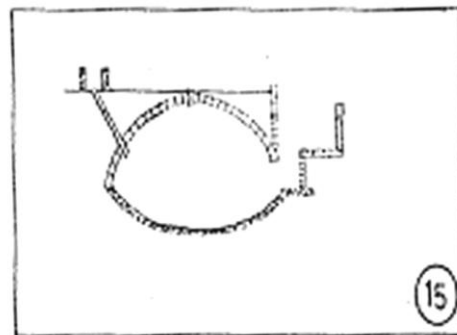

Completed biogas plant

Fig. Construction of Deenbandhu biogas plant

Lecture-16

Biofuels and characteristics

Biofuels and Ethanol

“Biofuels” are transportation fuels like ethanol and biodiesel that are made from biomass materials. These fuels are usually blended with petroleum fuels namely with gasoline and diesel fuel, but they can also be used on their own. Ethanol and biodiesel are also cleaner burning fuels, producing fewer air pollutants. It has drawn significant attention due to increasing environmental concern and diminishing petroleum reserves. Bio-diesel fuel can be made from renewable vegetable oils, animal fats or recycled cooking oils by trans esterification process. Biodiesel is the fastest growing alternative fuel in the world. Ethanol is a alcohol fuel made from the sugars found in grains such as corn, sorghum, and wheat, as well as potato skins, rice, sugarcane, sugar beets and yard clippings by fermentation. 14.0 Characteristics of bio-fuels. The following are some of the characters for the efficient bio-diesel:

- a) Kinematic viscosity
- b) Density
- c) Calorific value
- d) Melt or pour point
- e) Cloud point
- f) Flash point
- g) Acid value
- h) Iodine value
- i) Cetane number
- j) Stability – oxidative, storage and thermal
- k) Carbon residue
- l) Ash percentage
- m) Sulphur percentage

Kinematic viscosity: Viscosity represents flow characteristics and the tendency of fluids to deform with stress. Viscosity affects injector lubrication and fuel atomization. Fuels with low viscosity may not provide sufficient lubrication for the precision fit of fuel injection pumps, resulting in leakage or increased wear. Fuel atomization is also affected by fuel viscosity. Diesel fuels with high viscosity tend to form larger droplets on injection which can cause poor combustion, increased exhaust smoke and emissions.

Density: It's the weight per unit volume. Oils that are denser contain more energy. For example, petrol and diesel fuels give comparable energy by weight, but diesel is denser and hence gives more energy per litre. Biodiesel is generally denser than diesel fuel with sample values ranging

Renewable Energy

between 877 kg/m³ to 884 kg/m³ compared with diesel at 835 kg/m³. Thus, density of the final product depends mostly on the feedstock used.

Calorific Value: Heat of combustion Heating Value or Heat of Combustion, is the amount of heating energy released by the combustion of a unit value of fuels. One of the most important determinants of heating value is moisture content. Liquid biofuels however have bulk densities comparable to those for fossil fuels.

Melt point or Pour point Melt or pour point: It refers to the temperature at which the oil in solid form starts to melt or pour. In case where the temperatures fall below the melt point, the entire fuel system including all fuel lines and fuel tank will need to be heated.

Cloud point: The temperature at which an oil starts to solidify is known as the cloud point. While operating an engine at temperatures below an oil's cloud point, heating will be necessary in order to avoid waxing of the fuel.

Flash point (FP) : The flash point temperature of diesel fuel is the minimum temperature at which the fuel will ignite (flash) on application of an ignition source. Flash point varies inversely with the fuel's volatility. Minimum flash point temperatures are required for proper safety and handling of diesel fuel. The flash point determines the flammability of the material. Neat biodiesel has a flash point (150°C) well above the flash point of petroleum based diesel fuel ($\pm 70^\circ\text{C}$).

Acid value: The total acid number is an indication of the presence of free fatty acids formed due to oil degradation and combustion. It can also result from improper manufacturing, through remaining catalyst or excessive neutralization.

Iodine value: It is an index of the number of double bonds in biodiesel, and therefore is a parameter that quantifies the degree of unsaturation of biodiesel. It is reported in terms of the grams of iodine that will react with 100 grams of a fat or oil under specified condition. It is a value of the amount of iodine, measured in grams, absorbed by 100 grams of given oil. It is commonly used as a measure of the chemical stability properties of different biodiesel fuels against such oxidation.

Aniline point/Cetane number (CN): It is a relative measure of the interval between the beginning of injection and auto-ignition of the fuel. The higher the cetane number, the shorter the delay interval and the greater its combustibility. Fuels with low Cetane Numbers will result in difficult starting, noise and exhaust smoke. In general, diesel engines will operate better on fuels with Cetane Numbers above 50. Cetane number is usually measured directly using a test engine. Cetane tests provide information on the ignition quality of a diesel fuel. No.2 diesel fuel usually has a cetane rating between 45 and 50 while vegetable oil is 35 to 45. Biodiesel is usually have in between 50 to 60.

Stability: Biodiesel ages more quickly than petroleum diesel fuel due to the chemical structure of fatty acids and methyl esters present in biodiesel. Typically there are fourteen types of fatty acid methyl ester in the biodiesel. The individual proportion of presence of these esters in the fuel affects the final properties of biodiesel. Poor oxidation stability can cause fuel thickening, formation of gums and sediments which in turn can cause filter clogging and injector fouling. Thermal degradation occurs at high temperature and degrades hyper peroxide in the fuel more rapidly than oxidative degradation. Biodiesel and biodiesel blends are much more thermally stable than diesel. Biodiesel and its blends should not be stored in a storage tank or vehicle tank more than 6 months. Depending upon the storage temperature and other conditions suggest the use of appropriate antioxidants.

Carbon residue: This indicates the tendency of fuel to form carbon deposits in an engine. An important indicator of the quality of biodiesel is the carbon residue, which corresponds to the content of glycerides, free fatty acids, soaps, polymers and remaining catalyst.

Ash Percentage: Ash is a measure of the amount of metals contained in the fuel. High concentrations of these materials can cause injector tip plugging, combustion deposits and injection system wear. The ash content is important for the heating value, as heating value decreases with increasing ash content. Ash content for bio-fuels is typically lower than for most coals, and sulphur content is much lower than for many fossil fuels.

Sulfur percentage : The percentage by weight, of sulfur in the fuel sulfur content is limited by law to very small percentages for diesel fuel used in on-road applications. First use vegetable oil and animal fat based biodiesel has less than 15 ppm sulphur. Many researchers claim that pure biodiesel is essentially sulphur free and therefore biodiesel is an ultra-low sulphur fuel.

Bio-diesel

Batch process

Preparation:

- 1) Care must be taken to monitor the amount of water and free fatty acids in the incoming bio-lipid (oil or fat). If the free fatty acid level or water level is too high it may cause problems with soap formation and the separation of the glycerin by-product downstream.
- 2) Catalyst is dissolved in the alcohol using a standard agitator or mixer.
- 3) The alcohol/catalyst mix is then charged into a closed reaction vessel and the biolipid (vegetable or animal oil or fat) is added. The system from here on is totally closed to the atmosphere to prevent the loss of alcohol.
- 4) The reaction mix is kept just above the boiling point of the alcohol (around 70 °C) to speed up the reaction. Some systems recommend the reaction take place anywhere from room temperature

Renewable Energy

to 55 °C for safety reasons. Recommended reaction time varies from 1 to 8 hours; under normal conditions the reaction rate will double with every 10 °C increase in reaction temperature. Excess alcohol is normally used to ensure total conversion of the fat or oil to its esters.

5) The glycerin phase is much denser than biodiesel phase and the two can be gravity separated with glycerin simply drawn off the bottom of the settling vessel. In some cases, a centrifuge is used to separate the two materials faster.

6) Once the glycerin and biodiesel phases have been separated, the excess alcohol in each phase is removed with a flash evaporation process or by distillation. Care must be taken to ensure no water accumulates in the recovered alcohol stream.

7) The by-product (i.e., glycerin) contains unused catalyst and soaps, that are neutralized with an acid and sent to storage as crude glycerin.

8) Once separated from the glycerin, the biodiesel is sometimes purified by washing gently with warm water to remove residual catalyst or soaps, dried, and sent to storage.

Supercritical process

It is a catalyst-free method and continuous process. In this method, transesterification process uses supercritical methanol at high temperatures and pressures. In the supercritical state, the oil and methanol are in a single phase, and reaction occurs spontaneously and rapidly. The process can tolerate water in the feedstock. Also the catalyst removal step is eliminated. High temperatures and pressures are required, but energy costs of production are similar or less than catalytic production routes.

Ultra- and high-shear in-line and batch reactors

Ultra- and High Shear in-line or batch reactors allow production of biodiesel continuously, semi-continuously, and in batch-mode. This method drastically reduces production time and increases production volume. The reaction takes place in the high-energetic shear zone of the ultra- and high Shear mixer by reducing the droplet size of the immiscible liquids such as oil or fats and methanol. Therefore, the smaller the droplet size, the larger the surface area the faster the catalyst can react.

Ultrasonic-reactor method

In the ultrasonic reactor method, the ultrasonic waves cause the reaction mixture to produce and collapse bubbles constantly. This cavitation provides simultaneously the mixing and heating required to carry out the transesterification process. The ultrasonic reactor method for biodiesel production drastically reduces the reaction time, reaction temperatures, and energy input. Industrial scale ultrasonic devices allow for the industrial scale processing of several thousand barrels per day.

Microwave method

Current research is being directed into using commercial microwave ovens to provide the heat needed in the transesterification process. The microwaves provide intense localized heating that may be higher than the recorded temperature of the reaction vessel. A continuous flow process producing 6lt/min at a 99% conversion rate has been developed and shown to consume only one-fourth of the energy required in the batch process. Although it is still in the lab-scale, development stage, the microwave method holds great potential to be an efficient and cost-competitive method for commercial-scale biodiesel production.

Preparation of bio diesel from jatropha curcas

In most of the developed countries, biodiesel is produced from soybean, rapeseed, sunflower, peanut, etc., which are essentially edible in Indian context. Among the various vegetable oil sources, non-edible oils are suitable for biodiesel production. Because edible oils are already in demand and too expensive than diesel fuel. Among the non-edible oil sources, *Jatropha curcas* is identified as potential biodiesel source and comparing with other sources, which has added advantages as rapid growth, higher seed productivity, suitable for tropical and subtropical regions of the world. The *Jatropha* plant can reach a height up to 5 m and its seed yield ranges from 7.5 to 12 tonnes per hectare per year, after five years of growth. The oil content of whole *Jatropha* seed is 30-35 % by weight basis. Several properties of the plant including its hardness, rapid growth, easy propagation and wide ranging usefulness have resulted in its spread far beyond its original distribution. Preparation of bio diesel from *jatropha* requires a two-step approach; the extraction of the *Jatropha* oils from the seed, and the conversion of the extracted oil to Biodiesel, according to the following transesterification reaction. The mechanical extraction was done using a hydraulic press. After dehulling, the *Jatropha* seeds were first pressed to extract oil and then placed inside a soxhlet and brought into contact with a condensed solvent. The solvent dissolves the oil and then it is later separated using a rotor vapor. The obtained *Jatropha* oil was used for Biodiesel production. The transesterification reaction was done using methanol and two basic catalysts. Solvent extraction has higher oil yield than hydraulic press extraction.

Ethanol from agricultural produce (Sugar cane and corn)

Non-petroleum fuels liquid fuels find use when petroleum fuels are scarce or costly. The scientists have been in search of new fuels to replace conventional fuels that are used in IC engines. Among all the fuels, alcohols, which can be produced from sugarcane waste and many other agricultural products, are considered the most promising fuels for the future. There are two types of alcohols: methanol (CH₃OH) and ethanol (C₂H₅OH). Ethanol has attracted a lot of attention as a transport fuel because it is relatively cheap non-petroleum-based fuel. Also, the emissions from the combustion of ethanol are much less than for fossil fuels. Ethanol, being a pure compound, has a fixed set of physical as well as chemical properties. This is in contrast to

Renewable Energy

petrol and diesel, which are mixtures of hydrocarbons.. But in countries like India, ethanol is a strong candidate since they possess the agricultural resources for its production. It is a more attractive fuel for India because the productive capacity from sugarcane crops is high, of the order of 1345 l/ha. Earlier, this fuel was not used in automobiles due to low energy density, high production cost and corrosion. The current shortage of gasoline has made it necessary to substitute ethanol as fuel in SI engines. At present, Brazil is the only country that produces fuel alcohol on a large scale from agricultural products (mainly sugarcane). Brazil was the first and biggest producer of cheapest bio-ethanol in the world. Second cheapest bio-ethanol is made from corn in the USA. Properties of ethanol and methanol are similar, with difference of only 5 -10%. Ethanol is superior to methanol as it has wider ignition limit (3.5 -17) than methanol (2.15 -12.8). Ethanol calorific value (26,880 kJ/kg) is considerably higher than methanol (19,740 kJ/kg). Ethanol is a much more superior fuel for diesel engines as its cetane number is 8.

Compared to the cetane number of 3 for methanol, Ethanol is used in racing cars due to its very high heat of vaporization. 16.1 Manufacture of ethanol Three different feed stocks are available for ethanol production such as, sugar feed stock i.e., sugarcane and sugar beet; starch feed stock i.e., cereal grains and potato and cellulose feed stock i.e., forest products and agricultural residues. 16.1.1 Ethanol from starchy feed stock (grains) Ethanol production from cereal grains such as barley, wheat and corn is a much easier process than from cellulose material. The process includes several steps, as listed below:

- a) Milling of grains
- b) Hydrolysis of starch to sugar units
- c) Fermentation by yeast
- d) Distillation
- e) Removal of water from ethanol

After grinding the raw material, it is mixed with water and enzymes to break down the starch to sugar units. The free sugar can be used by yeast or bacteria and converted to ethanol and carbon dioxide. As the concentration of ethanol increases to about 15%, fermentation is reduced, since high alcohol concentration kills the yeast or bacteria. It is then necessary to separate the ethanol from the other material in the fermentation tanks by distillation. Distillation increases the ethanol concentration up to about 95%. In order to remove the rest of the water from the ethanol solution, it must be dried by different drying agents to a concentration of 99.5% ethanol or absolute ethanol. Extractive distillation with benzene also yields anhydrous ethanol. It is possible to produce 1 litre of absolute ethanol from about 3 kg of wheat.

Ethanol production from sugarcane is one of the easiest and most efficient processes since sugarcane contains about 15% sucrose. The glycosidic bond in the disaccharide can be broken down into two sugar units, which are free and readily available for fermentation. The cane is cut and the juice is extracted by maceration. After clarification, the juice is concentrated by boiling. The concentrated juice is fermented with yeast to produce raw ethanol. A series of distillation

Renewable Energy

steps including a final extractive distillation with benzene are used to obtain anhydrous ethanol. The normal yield of ethanol is about 8.73 litres of alcohol per tonne of cane. The potential of ethanol production in India is about 475 litres per year.

Lecture –17

Biodiesel

Biodiesel production method-flowchart-components-byproducts-utilization

TNAU biodiesel pilot plant

For the esterification of Jatropha oil, alkaline-based catalyst is used in this plant. The Jatropha oil is blended with alcohol and catalyst mixture. The oil extracted from the seeds of Jatropha is mixed with methanol catalyst mixture at a proportion under a particular temperature. This solution is continuously stirred for two hours. During the above process, glycerol present in the solution separate out, which when settled can be separated out. For settling, three separate tanks are provided in the plant. After removing the glycerol, the liquid biodiesel is transferred to washing tank, where the fuel is washed twice and the purified biodiesel is obtained.

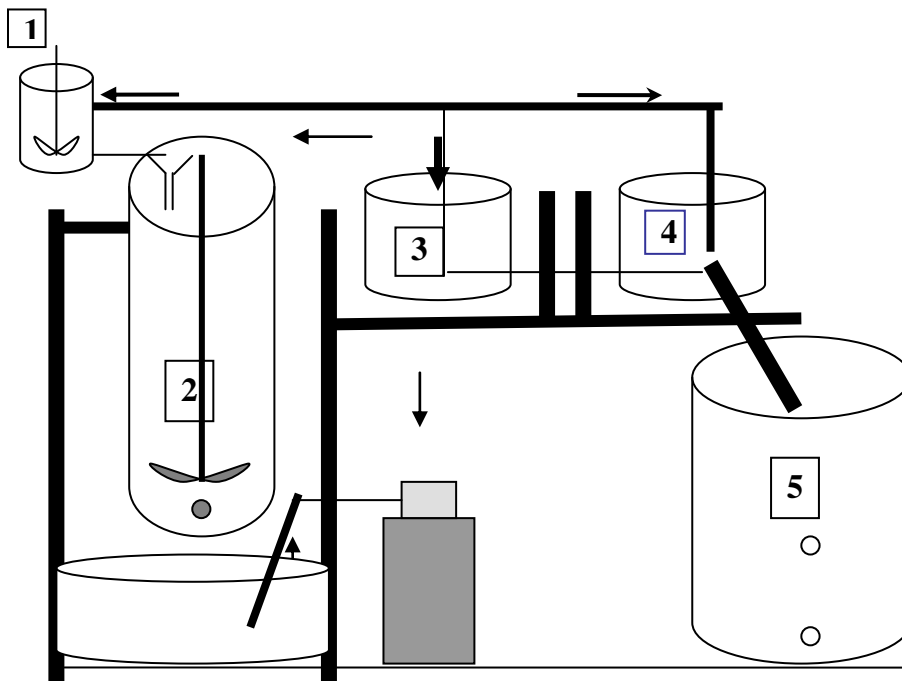

Fig. Biodiesel pilot plant diagrammatic sketch

- 1. Mixing tank for chemical
- 2. Main reactor
- 3 & 4. Settling tanks
- 5. Washing tank

Renewable Energy

By using the above unit, about 250 litres of biodiesel could be produced in a day. The cost of the unit is approximately 1.5 lakhs. This could be reduced by appropriate substitutions in the existing plant. Depending upon the need, the size of the unit can be scaled up to get higher capacity.

Process flow chart

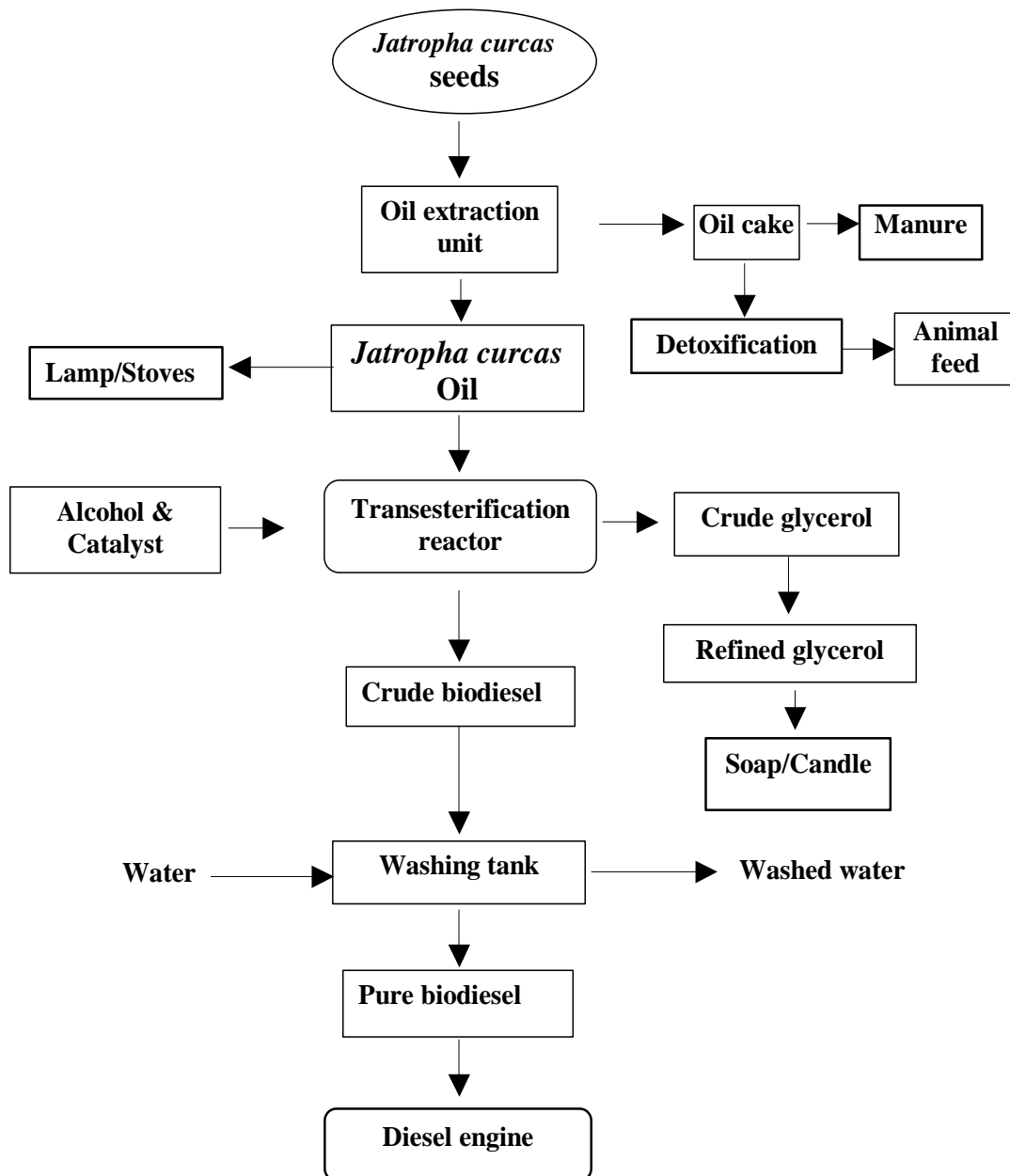

Mechanics of the transesterification process

1. Take 50 litres of Jatropha oil in the container and pump oil from inlet tank to biodiesel reactor by using inlet pump (10 minutes)
2. Switch ON for heater of biodiesel reactor
3. Take 20 per cent of methanol and 1 per cent of sodium hydroxide (by weight of oil) in the chemical mixing tank. Ensure that gate valve for chemical tank is in closed position before filling of methanol into tank
4. Switch ON for stirrer of chemical mixing tank (15 minutes) to produce the sodium methoxide solution
5. After reaching reaction temperature 60 deg. C, the sodium methoxide is send to biodiesel reactor by opening of gate valve and close the valve.
6. Switch ON for main stirrer of biodiesel reactor and reaction is continued for about 2 hours
7. After reaction time is completed, open the gate valve for glycerol settling tank and the biodiesel and glycerol mixer is send to the glycerol settling tank (by using storage switch)
8. Allow the biodiesel mixture in glycerol settling tanks for 12 hours
9. Before feeding of raw biodiesel, fill 100 litres of water in the washing tank
10. Remove the glycerol from settling tank and biodiesel is sent to washing tank by opening gate
11. Switch ON the aerator for 30 minutes. Allow the sample for 3 hours and remove the biodiesel from washing tank
12. Heat the biodiesel for 20 minutes to remove the moisture.

POST PRODUCTION PROCESS

Refining (Cleaning)

The esters recovered from the reaction mixture are refined to meet the requirements of ASTM D 6751-2. The topics include: biodiesel/glycerol separation, ester washing, ester drying, other ester treatments and additization.

Biodiesel/glycerol separation

The biodiesel /glycerol separation is typically the first step of product recovery in most biodiesel processes. The separation process is based on the facts that fatty acid alcohol esters and glycerol are sparingly mutually soluble, and that there is a significant difference in density between the ester and glycerol phases. The presence of methanol in one or both phases affects the solubility of ester in glycerol and glycerol in ester.

The biodiesel washing step is used to neutralize any residual catalyst, to remove any soaps formed during the esterification reaction and to remove residual free glycerol and methanol.

Ester drying is required to meet the stringent limits on the amount of water present in the final biodiesel product. In addition, there may be other treatments used to reduce color bodies in the fuel, remove sulfur and phosphorus from the fuel, or to remove glycerides.

Additization is the addition of materials that have a specific functionality that modifies one or more fuel properties. Examples include cloud point/pour point additives, antioxidants, or other stability enhancing agents.

Fatty acid alcohol esters have a density of about 0.88 gm/cc, while the glycerol phase has a density on the order of 1.05 gm/cc, or more. The glycerol density depends on the amount of methanol, water, and catalyst in the glycerol. This density difference is sufficient for the use of simple gravity separation techniques for two phases.

Any of the three categories of the equipments viz., Decanter system or Centrifuge System or Hydro cyclone can be used to separate the ester and glycerol phases.

Lecture-18.

Biodiesel Production Processes

Bio-Diesel

Vegetable oils and their derivatives (especially methyl esters), commonly referred to as “biodiesel,” are prominent candidates as alternative diesel fuels. They have advanced from being purely experimental fuels to initial stages of commercialization. They are technically competitive with or offer technical advantages compared to conventional diesel fuel. Besides being a renewable and domestic resource, biodiesel reduces most emissions while engine performance and fuel economy are nearly identical compared to conventional fuels. Several problems, however, remain, which include economics, combustion, some emissions, lube oil contamination, and low-temperature properties.

Numerous different vegetable oils have been tested as biodiesel. Often the vegetable oils investigated for their suitability as biodiesel are those which occur abundantly in the country of testing. Therefore, soybean oil is of primary interest as biodiesel source in the United States while many European countries are concerned with rapeseed oil, and countries with tropical climate prefer to utilize coconut oil or palm oil. Other vegetable oils, including sunflower, safflower, etc., have also been investigated. Furthermore, other sources of biodiesel studied include animal fats and used or waste cooking oils. Several problems, however, have impaired the widespread use of biodiesel. They are related to the economics and properties of biodiesel. For example, neat vegetable oils reported to cause engine deposits. Attempting to solve these problems by using methyl esters causes operational problems at low temperatures. Furthermore, problems related to combustion and emissions remain to be solved. The problems associated with the use of biodiesel are thus very complex and no satisfactory solution has yet been achieved despite the efforts of many researchers around the world.

Conventional Diesel Fuel Diesel Engines

In contrast to gasoline, which is spark-ignited, the heat of compression in a diesel engine ignites DF after injection. The diesel engine is therefore also termed a compression-ignition (CI) engine. The differences in the ignition processes entail significant differences in chemical composition and physical properties of the fuels.

Conventional DF is, like gasoline, obtained from cracking of petroleum. It is a fraction boiling at an initial distillation temperature of 160° (90% range of 290-360°C) (7), also termed middle distillates because of its boiling range in the mid-range of cracking products.

The ignition quality of DF is commonly measured by ASTM D613 and reported as the cetane number (CN). Ignition quality is defined by the ignition delay time of the fuel in the engine. The shorter the ignition delay time, the higher the CN. To rank different compounds on the cetane

scale, hexadecane (C₁₆H₃₄; also called cetane), which has a very short ignition delay, has been assigned a CN of 100. At the other end of the scale, 2,2,4,4,6,8,8-heptamethylnonane (HMN; also C₁₆H₃₄), which has poor ignition qualities, has been assigned a CN of 15. It should be noted that the cetane scale is arbitrary and that compounds with CN > 100 (although the cetane scale does not provide for compounds with CN > 100) or CN < 15 have been identified. The ASTM specification for conventional DF (ASTM D975) requires a minimum CN of 40.

The CN scale clarifies an important aspect of the composition of, or, on a more fundamental level, the molecular structure of the compounds comprising DF. Long-chain, unbranched, saturated hydrocarbons (alkanes) have high CNs and good ignition quality while branched hydrocarbons (and other materials such as aromatics) have low CNs and poor ignition quality. Since both too high and too low CN can cause operational problems (in case of too high CN, combustion can occur before the fuel and air are properly mixed, resulting in incomplete combustion and smoke; in case of too low CN, engine roughness, misfiring, higher air temperatures, slower engine warm-up and also incomplete combustion occur), most engine manufacturers designate a range of required CN for their engines. In most cases, this range is around CN 40-50.

Conventional DF is classified into different grades by ASTM D 975. This classification is the following: No. 1 diesel fuel (DF1) comprises volatile fuels oils from kerosene to intermediate distillates. They are applicable for high-speed engines whose operation involves frequent and relatively wide variations in engine load and speed. Such fuel is required for use at abnormally low temperatures. No. 2 diesel fuel (DF2) includes distillate gas oils of lower volatility. This grade is suitable for use in high-speed engines under relatively high loads and uniform speeds. DF2 can be used in engines not requiring fuels having the greater volatility and other properties specified for No. 1 diesel fuels. DF2 is the transportation diesel fuel to which biodiesel is usually compared. No. 4 diesel fuel (DF4) covers the more viscous distillates and their blends with residual fuel oils. It is usually satisfactory only for low-speed and medium-speed engines operated under sustained load at nearly constant speed.

Besides the just discussed characteristics of conventional DF, other properties such as heat of combustion, pour point, cloud point, and viscosity are of great significance. These properties also play very important roles in the use of biodiesel.

The two general types of diesel engines are the direct injection (DI) engine and the indirect injection (IDI) engine. In DI engines, the fuel is directly injected into the combustion chamber in the cylinder. In IDI engines, the fuel is injected into a prechamber which is connected with the cylinder through a narrow passage. Rapid air transfer from the main cylinder into the prechamber promotes a very high degree of air motion in the prechamber which is particularly conducive to rapid fuel air mixing. Combustion beginning in the prechamber produces high pressure and the fuels are subjected to high shear forces. The IDI engine is no longer used for heavy bus and truck engines due to somewhat lower efficiency and higher fuel consumption than the DI system.

Renewable Energy

However, for special purposes, such as underground work, IDI engines are still made in the heavier class due to low exhaust emissions. For smaller vehicles such as cars and light trucks, the IDI system is used because of its ability to cover a wider speed range. The low exhaust emissions in combination with the wider speed range may lead to a continued use of IDI engines in urban areas, where the demand for low emissions can be more important than a somewhat higher fuel consumption combined with low annual mileage. The IDI engine is also less sensitive to fuel quality. Tests of biodiesel as a fuel have been performed on both DI and IDI engines.

Biodiesel.

The term biodiesel has no unambiguous definition. It stands for neat vegetable oils used as DF as well as neat methyl esters prepared from vegetable oils or animal fats and blends of conventional diesel fuel with vegetable oils or methyl esters. With increasing emphasis on the use of esters as DF, however, the term “biodiesel” increasingly refers to alkyl esters of vegetable oils and animal fats and not the oils or fats themselves. In an article on proposed ASTM standards, biodiesel was defined (9) as “the mono alkyl esters of long chain fatty acids derived from renewable lipid feedstock, such as vegetable oils or animal fats, for use in compression ignition (diesel) engines.” Nevertheless, clear distinction between these different vegetable oil-based or -derived alternative diesel fuels is necessary.

Vegetable oils.

Most vegetable oils are triglycerides (TGs; triglyceride = TG). Chemically, TGs are the triacylglyceryl esters of various fatty acids with glycerol.

Some physical properties of the most common fatty acids occurring in vegetable oils and animal fats as well as their methyl esters are listed in Table I. Besides these fatty acids, numerous other fatty acids occur in vegetable oils and animal fats, but their abundance usually is considerably lower. Table II lists the fatty acid composition of some vegetable oils and animal fats that have been studied as sources of biodiesel.



II



II



Triglyceride

Methanol

Methyl ester

Glycerol

The most common derivatives of TGs (or fatty acids) for fuels are methyl esters. These are formed by transesterification of the TG with methanol in presence of usually a basic catalyst to give the methyl ester and glycerol. Other alcohols have been used to generate esters, for example, the ethyl, propyl, and butyl esters.

Selected physical properties of vegetable oils and fats as they relate to their use as DF are listed in Table

Oil or Fat	Iodine Value	CN	HG (kJ/kg)	Viscosity (mm ² /s)	CP (°C)	PP (°C)	FP (°C)
Babassu	10-18	38					
Castor	82-88		39500	297 (38°)	---	-31.7	260
Coconut	6-12						
Corn	103-140	37.6	39500	34.9 (38°)	-1.1	-40.0	277
Cottonseed	90-119	41.8	39468	33.5 (38°)	1.7	-15.0	234
Crambe	93	44.6	40482	53.6 (38°)	10.0	-12.2	274
Linseed	168-204	34.6	39307	27.2 (38°)	1.7	-15.0	241
Olive	75-94						
Palm	35-61	42					
Peanut	80-106	41.8	39782	39.6 (38°)	12.8	-6.7	271
Rapeseed	94-120	37.6	39709	37.0 (38°)	-3.9	-31.7	246
Safflower	126-152	41.3	39519	31.3 (38°)	18.3	-6.7	260
High-oleic safflower	90-100	49.1	39516	41.2 (38°)	-12.2	-20.6	293
Sesame	104-120	40.2	39349	35.5 (38°)	-3.9	-9.4	260
Soybean	117-143	37.9	39623	32.6	-3.9	-12.2	254

				(38°)			
Sunflower	110-143	37.1	39575	37.1 (38°)	7.2	-15.0	274
Tallow	35-48	-	40054	51.15 (40°)	-	-	201
No. 2 DF		47	45343	2.7(38°)	-15.0	-33.0	52

Where,

CN = cetane number; CP = cloud point, PP = pour point, FP = flash point.

Combustion Chemistry, Emissions, Engine problems and deposits.

Generally, similar types of compounds are observed in the exhaust emissions of conventional DF and vegetable oil-derived fuels. This is additional proof of the suitability of fatty compounds as DF because there presumably exists similarities in their combustion behavior.

Emissions from any kind of engine are the result of the preceding combustion within in the engine. The combustion process, in relation to the properties of the fuel, and its completeness are responsible for any problems associated with the use of biodiesel, such as formation of deposits, etc. To understand the formation of emissions and deposits, and possibly direct the combustion to suppress undesirable emissions and deposits, it is essential to study the combustion of the fuel.

Ideally, the products of complete combustion of hydrocarbons are carbon dioxide (CO₂) and water according to the equation (shown for alkanes (saturated hydrocarbons))

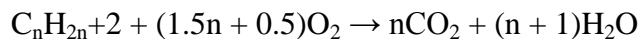

Combustion in a diesel engine occurs mainly through a diffusion flame and is therefore incomplete. This causes the formation of partially oxidized materials such as carbon monoxide (CO), other oxygenated species (aldehydes, etc.), and hydrocarbons. In the case of biodiesel, liberation of CO₂ (decarboxylation), as indicated above, from the ester moiety of the triglyceride or methyl ester occurs besides combustion formation of CO₂ from the hydrocarbon portions of biodiesel. The formation of CO₂, an incombustible compound despite its high oxygen content (although mistakenly assumed by some that it can serve as a combustion enhancer because of its high oxygen content), shows that one has to be judicious in choosing oxygenated compounds as combustion enhancers because the combustion-enhancing properties will depend on the nature of the oxygen (bonding, etc.) in those compounds. Therefore, the higher oxygen content of biodiesel does not necessarily imply improved combustion compared to conventional DF because of removal of this oxygen from the combustion process by decarboxylation, but CO₂ may contribute to combustion in other ways.

Exhaust emissions observed in the combustion of conventional DF and biodiesel are smoke, particulates (particulate matter), polyaromatic hydrocarbons (PAHs), hydrocarbons, CO, and oxides of nitrogen (NO_x; also referred to as nitrous oxides, or nitrogen oxides). An important difference are sulfur-containing emissions which are not formed from biodiesel due to its lack of sulfur. Note that rapeseed contains low amounts of sulfur but variations such as canola have not only lower erucic acid content but also reduced sulfur.

The composition of particulate matter has been studied for conventional diesel fuels. Particulates from conventional DF have a high carbon to hydrogen ratio of approximately 10:1. Thus, particulates are mainly carbon in forms of crystallites. As temperatures decrease below 500°C, the particles are coated with adsorbed and condensed species, which include unburned hydrocarbons, various oxygenated hydrocarbons, PAHs and nitrogen dioxide (in case of conventional DF, also sulfur-containing species). With rapeseed methyl ester as fuel in DI engines, particulate matter showed large amounts of volatile and extractable compounds adsorbed on the soot, which caused the particulate emissions to be higher than with conventional DF.

PAHs are compounds composed of fused aromatic rings that may carry alkyl substituents such as a methyl group. They are of concern because many of them are known carcinogens. Hydrocarbons represent a broad category of compounds including hydrocarbons and oxygenated species such as aldehydes, ketones, ethers, etc.

Nitrogen oxides (NO_x) arise by the reaction of nitrogen and oxygen from air at an early stage in the combustion process. NO_x emissions are difficult to control because such techniques may increase other emissions or fuel consumption.

Emissions of Neat Vegetable Oil Fuel.

While neat vegetable oils are competitive with conventional DF in some emission categories, problems were identified for other kinds of emissions. For example, it was shown that PAH emissions were lower for neat vegetable oils, especially very little amounts of alkylated PAHs, which are common in the emissions of conventional DF. Besides higher NO_x levels, aldehydes are reported to present problems with neat vegetable oils. Total aldehydes increased dramatically with vegetable oils. Formaldehyde formation was also consistently higher than with DF2. It was reported that component TGs in vegetable oils can lead to formation of aromatics via acrolein (CH₂=CH-CHO) from the glycerol moiety. Another author observed significantly lower emissions of C₃ aldehydes (for example, acrolein) for methyl esters of rapeseed oil than for the oil itself. Another study attributes increased emissions of aldehydes and ketones when using vegetable oils as fuels to the formation of acidic water during decomposition of the oils. This acidic water could be an indication for the formation of short-chain oxygenates which likely ignite poorly compared to the long-chain carbon-rich fatty compounds.

Engine Problems with Neat Vegetable Oil Fuel.

Most references in this section report that, at least in short-term trials, neat oils gave satisfactory engine performance and power output, often equal to or even slightly better than conventional DF. However, vegetable oils cause engine problems. This was recognized in the early stages of renewed interest in vegetable oil-based alternative DFs. Studies on sunflower oil as fuel noted coking of injector nozzles, sticking piston rings, crankcase oil dilution, lubricating oil contamination, and other problems. These problems were confirmed and studied by other authors. A test for external detection of coking tendencies of vegetable oils was reported. The causes of these problems were attributed to the polymerization of TGs via their double bonds which leads to formation of engine deposits as well as the low volatility and high viscosity with resulting poor atomization patterns. An oxidative free-radical mechanism was suggested as governing TG polymerization in lubricating oil contamination when using sunflower oil as fuel. Fumigation with propane was studied as a means to reduce injector coking. The engine problems have caused neat vegetable oils to be largely abandoned as alternative DF and lead to the research on the aforementioned four solutions.

Emissions of esters. Generally, most emissions observed for conventional DF are reduced when using esters. NO_x emissions are the exception. In an early paper reporting emissions with methyl and ethyl soyate as fuel, it was found that CO and hydrocarbons were reduced but NO_x were produced consistently at a higher level than with the conventional reference DF. The differences in exhaust gas temperatures corresponded with the differences in NO_x levels. Similar results were obtained from a study on the emissions of rapeseed oil methyl ester. NO_x emissions were slightly increased, while hydrocarbon, CO, particulate and PAH emissions were in ranges similar to the DF reference. As mentioned above, the esters emitted less aldehydes than the corresponding neat rapeseed oil. Unrefined rapeseed methyl ester emitted slightly more aldehydes than the refined ester, while the opposite case held for PAH emissions. A 31% increase in aldehyde and ketone emissions was reported when using rapeseed methyl ester as fuel, mainly due to increased acrolein and formaldehyde, while hydrocarbons and PAHs were significantly reduced, NO_x increased slightly, and CO was nearly unchanged. The study on PAH emissions, where also the influence of various engine parameters was explored, found that the PAH emissions of sunflower ethyl ester were situated between DF and the corresponding neat vegetable oil. Reduced PAH emissions may correlate with the reduced carcinogenicity of particulates when using rapeseed methyl ester as fuel. The general trend on reduced emissions except NO_x was confirmed by later studies, although some studies report little changes in NO_x. In a DI engine, sunflower methyl ester produced equal hydrocarbon emissions but less smoke than a 75:25 blend of sunflower oil with DF. Using a diesel oxidation catalyst (DOC) in conjunction with soy methyl ester was reported to be a possible emissions reduction technology for underground mines. Soy methyl esters were reported to be more sensitive towards changes in engine parameters than conventional DF.

Precombustion of Triglycerides

As discussed, every DF, conventional or vegetable oil-based, experiences an ignition delay, which is the basis of CN measurements. The fuel passes through a temperature and pressure gradient directly after injection but before combustion begins. Chemical reactions already occur in this precombustion phase. In an initial study, the unsaturated TGs triolein, trilinolein, and trilinolenin were studied at temperatures up to 400°C in air or N₂ in a reactor simulating conditions in a diesel engine. The compounds arising in this phase were fatty acids of different chain lengths (some even longer than those in the parent fatty acids), various aliphatic hydrocarbons, and smaller amounts of other compounds such as aldehydes. The parent acids were the most prominent compounds in the precombustion mixture. Component patterns were largely independent of the starting material and reaction conditions. In a second study, tristearin and tripalmitin were studied besides the three unsaturated TGs at temperatures of 450°C in air and N₂. Presumably due to the higher temperature, different component patterns were observed. Besides mainly unsaturated aliphatic hydrocarbons and unsaturated aldehydes, various aromatics, including benzene, toluene, compounds with unsaturated side chains, and polyaromatic hydrocarbons were detected. The atmosphere (air or N₂) had considerable influence on product formation. The number of components was less for samples of tripalmitin, tristearin and triolein for reactions under N₂ than under air while this finding was reversed for trilinolein and trilinolenin. No fatty acids, glycerol or acrolein (as decomposition product of glycerol) were detected. Extensive decarboxylation occurred, showing that the oxygen in biodiesel does not necessarily contribute to its combustion as an oxidizer. The compounds identified are also found in the exhaust emissions of engines running on conventional DF. It is therefore necessary to influence not only combustion but also precombustion to improve the combustion properties and emissions of biodiesel.

Cetane Improvers. Various compounds such as alkyl nitrates are used as cetane-enhancing additives in conventional DF. Few studies on such compounds in biodiesel exist. One paper reports that in a turbulence combustion chamber and at an intake air temperature of 105°C, 8% hexyl-nitrate in vegetable oils (cottonseed, rape, and palm) was necessary to exhibit the same ignition delay as conventional DF. The use of nitrate esters of fatty acids as cetane improvers in DF was reported in a patent.

Dilution of vegetable oils with conventional diesel fuel

Dilution is an additional possible solution to the viscosity problem of vegetable oils as discussed above. Results with this technology have been mixed and engine problems similar to those found with neat vegetable oils as fuels were observed here also. A model on vegetable oil atomization showed that blends of DF2 with vegetable oil should contain from 0 to 34% vegetable oil if proper atomization was to be achieved.

A 75:25(vol-%) petrodiesel / sunflower oil blend had a viscosity of 4.88 mm²/s at 40°C, exceeding the ASTM maximum value of 4.0. The blend was not recommended for long-term use in the DI diesel engine (64). A 75:25 (vol-%) petrodiesel / high-oleic safflower oil blend with a viscosity of 4.92 mm²/s passed the 200 hr EMA (Engine Manufacturers Association) test. The different results were attributed to the degree of unsaturation of the respective vegetable oil. The more unsaturated oil (sunflower) that accumulates in the crankcase and hot engine parts tends to oxidize and polymerize due to its reactivity. Accumulation of such products in the lube oil could lead to lubricant thickening. A lube oil change is called for by the EMA test after 100 hr and at that time the viscosity of the lube oils had not varied greatly in either test.

Other reports include successfully using a 70:30 winter rapeseed oil / DF1 mixture or blends of ≤ 15% rapeseed oil with DF2 , and an 80:20 DF2 / safflower oil blend with reduced CO and hydrocarbon emissions. A 75:25 DF / crude sunflower oil blend produced greatest solids contamination in the lubricating oil (49) similar to the results mentioned above, while another report mentions satisfactory performance of a 75:25 DF / sunflower oil blend. In early studies on sunflower oil, 80:20 DF / sunflower oil blends were run for prolonged periods of time before exhaust smoke increased due to carbon build-up or power loss ensued. Another engine, due to inadequate atomization, showed more of the engine problems associated with neat vegetable oils.

The CP of a 50:50 DF2/ high-oleic safflower oil was -13°C and the PP was -15°C, and similar blends with high-linoleic safflower oil had CP -13°C and PP -15°C or winter rapeseed oil had CP -11°C and PP -18°C .

A 50:50 blend of Stoddard solvent (a dry-cleaning fluid, viscosity 0.95 mm²/s, estimated CN 50, heat of combustion 46,800 kJ/kg, CP < -16°C, PP < -35°C, flash point 42.2°C) with soybean oil gave low CP (-18.9°C) and PP (-31.7°C) but performed less well in a diesel engine than DF2.

Transesterification.

The conversion of component TGs to simple alkyl esters (transesterification) with various alcohols reduces the high viscosity of oils and fats. Base catalysis of the transesterification with reagents such as sodium hydroxide is preferred over acid catalysis because the former is more rapid. Transesterification is a reversible reaction. The transesterification of soybean oil with methanol or 1-butanol proceeded with pseudo-first order or second order kinetics, depending on the molar ratio of alcohol to soybean oil (30:1 pseudo-first order, 6:1 second order; NaOBu catalyst) while the reverse reaction was second order.

Methyl esters are the most “popular” esters for several reasons. One reason is the low price of methanol compared to other alcohols. Generally, esters have significantly lower viscosities than the parent oils and fats. Accordingly, they improve the injection process and ensure better atomization of the fuel in the combustion chamber. The effect of the possible polymerization reaction is also decreased. The advantages of alkyl esters were noted early in studies on the use of sunflower oil and its esters as DF. Another advantage of the esters is possibly more benign

emissions, for example, with the removal of glycerol (which is separated from the esters) the formation of undesirable acrolein may be avoided, as discussed above. These reasons as well as ease and rapidity of the process are responsible for the popularity of the transesterification method for reducing the viscosity-related problems of vegetable oils. The popularity of methyl esters has contributed to the term “biodiesel” now usually referring to vegetable oil esters and not neat vegetable oils.

In the early studies on sunflower esters, no transesterification method was reported. Another early study used H_2SO_4 as the transesterification catalyst. It was then shown, however, that in homogeneous catalysis, alkali catalysis is a much more rapid process than acid catalysis in the transesterification reaction (74, 77). At 32°C , transesterification was 99% complete in 4 h when using an alkaline catalyst (NaOH or NaOMe). At 60°C and a molar ratio alcohol:oil of at least 6:1 and with fully refined oils, the reaction was complete in 1 h to give methyl, ethyl, or butyl esters. The reaction parameters investigated were molar ratio of alcohol to vegetable oil, type of catalyst (alkaline vs. acidic), temperature, reaction time, degree of refinement of the vegetable oil, and effect of the presence of moisture and free fatty acid. Although the crude oils could be transesterified, ester yields were reduced because of gums and extraneous material present in the crude oils.

Besides sodium hydroxide and sodium methoxide, potassium hydroxide is another common transesterification catalyst. Both NaOH and KOH were used in early work on the transesterification of rapeseed oil. Recent work on producing biodiesel (suitable for waste frying oils) employed KOH. With the reaction conducted at ambient pressure and temperature, conversion rates of 80 to 90% were achieved within 5 minutes, even when stoichiometric amounts of methanol were employed. In two steps, the ester yields are 99%. It was concluded that even a free fatty acid content of up to 3% in the feedstock did not affect the process negatively and phosphatides up to 300 ppm phosphorus were acceptable. In a study, similar to previous work on the transesterification of soybean oil, it was concluded that KOH is preferable to NaOH in the transesterification of safflower oil of Turkish origin. The optimal conditions were given as 1 wt-% KOH at $69\pm 1^\circ\text{C}$ with a 7:1 alcohol : vegetable oil molar ratio to give 97.7% methyl ester yield in 18 minutes.

Lecture –19

Bio-ethanol production flowchart – applications in transport sector

Bio-ethanol is an environmentally friendly fuel for vehicles that normally run on petrol. As a renewable source of energy, it reduces demand on fossil fuels while it burns more cleanly and with reduced emissions of CO₂, a greenhouse gas. As an energy source, bio-ethanol is carbon neutral in that it reduces, by up to 70 %, the amount of greenhouse gas released into the atmosphere. The CO₂ released during ethanol production and combustion in an engine has already been absorbed from the atmosphere during the growth of the crops due to photosynthesis. The reduction of greenhouse gases, to meet the climate change targets set by the Kyoto Protocol, is responsible for fuelling the current boom in biofuels.

Bio-ethanol is a versatile transportation fuel and fuel additive that offers excellent performance and reduced air pollution compared to conventional fuels. Its production and use adds little, if any, net release of carbon dioxide to the atmosphere, dramatically reducing the potential for global climate changes.

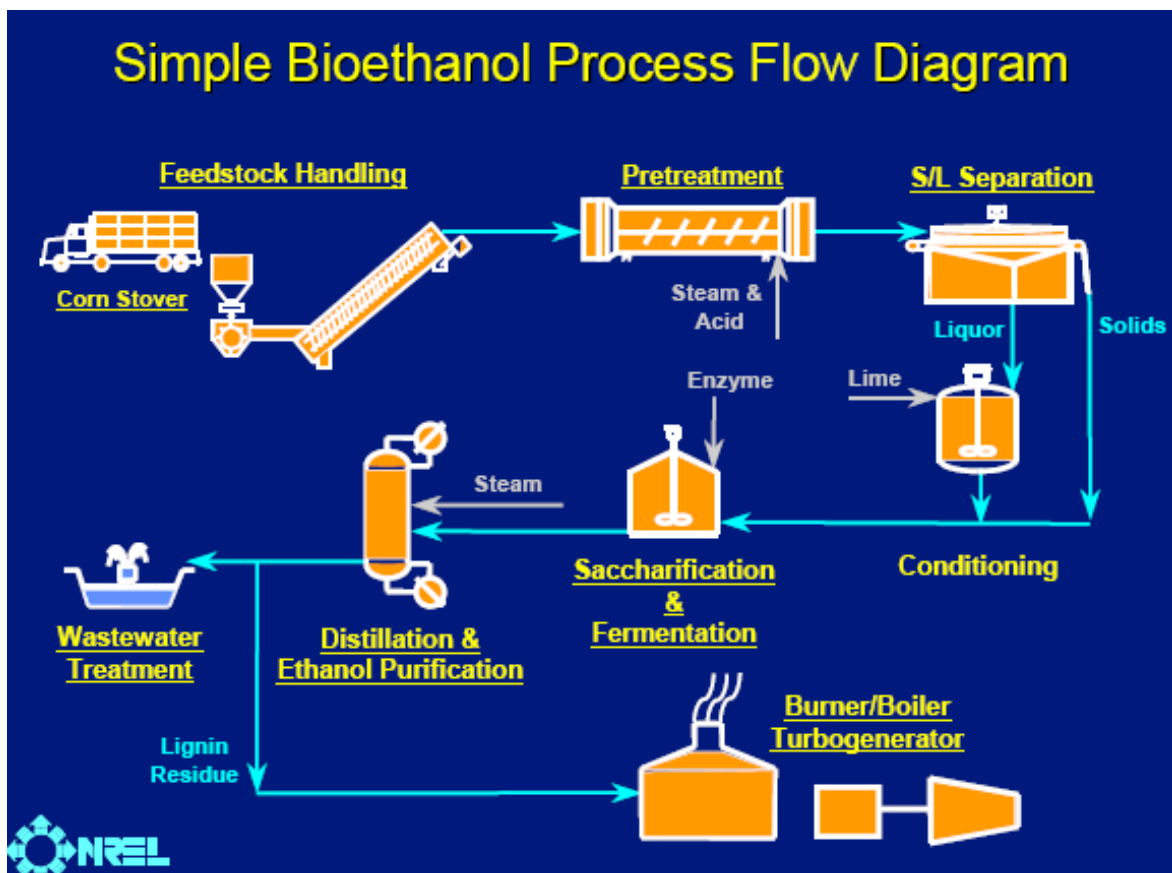

Bio-ethanol is produced by the fermentation of sugar, a well established process used in the production of beer and alcohol.

Carbohydrates such as starch from cereal and tuber crops – which is enzymatically converted into simple sugars – and natural sugars from sugar beet, sugar cane and sweet sorghum crops are fermented using yeast to produce a mash containing ethanol, water and unfermented solids. Distillation columns separate ethanol from the fermented mash, with additional purification taking place in rectification columns to produce an ethanol and water mixture. Dehydration is the step of removing the last of the water, taking the mixture beyond its azeotropic equilibrium to produce anhydrous ethanol, or bio-ethanol.

A significant advantage of bio ethanol is that it can be blended with petrol as both an oxygenator and octane enhancer. Environmental concerns due to the widespread use of MTBE (methyl tertiary butyl ether, a possible carcinogen) in unleaded petrol have prompted drives to seek alternatives. Bio-ethanol provides an ideal solution in that it is a renewable and environmentally friendly petrol extender, while providing a direct substitute for MTBE as an octane enhancer. Ethanol is also suitable as a feedstock for producing other octane enhancers such as ETBE (ethyl tertiary butyl ether) or TAEE (tertiary amyl ethyl ether), considered safer than MTBE.

Additional revenue streams are available from the spent products that result from ethanol production. These are usually dried to produce DDGS (distiller's dried grains with solubles) marketed as a protein and nutrient rich animal feed for cattle, pigs and poultry. Alternatively, the biomass can be utilised as a renewable fuel source, producing electrical power and heat for the process, or for conversion into methane for use as a fuel. These energy conversion technologies enhance the overall production energy balance and enable further *carbon credits* to be earned.

Advantages Of Bio-ethanol

The overwhelming advantage of bio-ethanol for the environment is its potential to be carbon neutral on a lifecycle basis – meaning the carbon dioxide (CO₂) emitted during its use is offset by the absorption from the atmosphere during its growth.

Renewable Energy

With emissions of CO₂ and nitrous oxide taken into account, some studies suggest that lifecycle greenhouse gas emissions can be reduced by 90% with bio-ethanol compared to petrol. This is a best-case scenario however, using sugar cane as the crop and large amounts of bagasse (the remaining wood fibres after the juice is extracted) used for heat energy. Nevertheless, even by current European standards the emission reductions are significant – around 35-65% depending on the processing method.

Bio-ethanol also has the advantage of lower taxation. The UK government has reduced fuel duty on bio-ethanol, which offsets the higher production costs. The first supermarkets in the UK selling E85 offered it at around 2p cheaper than conventional petrol but typically you would use much more bio-ethanol per mile than traditional fuel – around 50% more if you're using 100% bio-ethanol.

DISADVANTAGES OF BIOETHANOL

There are many concerns over the use of bio-ethanol as a long-term alternative in the fuelling of cars. These include:

- Biodiversity – A large amount of arable land is required to grow crops. This could see some natural habitats destroyed including rainforests.
- The food v fuel debate – There is concern that due to the lucrative prices of bio-ethanol some farmers may sacrifice food crops for biofuel production which will increase food prices around the world.
- Carbon emissions – There is debate over the neutrality of bio-ethanol when all elements are taken into consideration including the cost of changing the land use of an area, transportation and the burning of the crop.

There are also concerns over the fuel systems used. Too many older cars are currently unequipped to handle even 10% ethanol while there is concern that using 100% ethanol decreases fuel economy by around 15-30% compared with 100% petroleum.

FUEL ECONOMY- PRICES, POLICY – ENERGY CRISIS

The capital costs occurred to be always the most expensive position in conversion, followed by the expenditures for process steam input. The expenses for

electricity formed the lowest proportion. Approximately 75% of the process auxiliary costs were due to the technical enzyme products.

Generally, as the crop production intensity increased, the conversion costs on a per hectare basis increased as well. The increment was proportional to the grain yield increase, since the costing are based on the specific amount of processed grain per hectare and not on the amount of bio-ethanol produced. This method allows appreciating the economic advantage of increased bio-ethanol conversion rates per equivalent tons of grain. As the calculations prove, the conversion costs on a per liter basis were relatively the same independent of the scale that results directly from the applied method of costing. However, the results revealed that the conversion costs per liter of bio ethanol produced were evidently affected by the bio ethanol conversion rates, which depended primarily on the genotype's fermenting traits.

Bio-ethanol can reduce the environmental impact of the transport sector:

The transport sector is responsible for about one fifth of CO₂ emissions on a global scale. If nothing is done, transport is expected to be the main driver of future global CO₂ emission increases. Bio ethanol and bio diesel are currently the only readily available alternatives to fossil fuel.

It is now commonly accepted that first generation bio-ethanol is able to reduce CO₂ emissions by between 20 and 50% compared to petroleum based fuels depending on the energy efficiency of the bio-

First-generation bioethanol

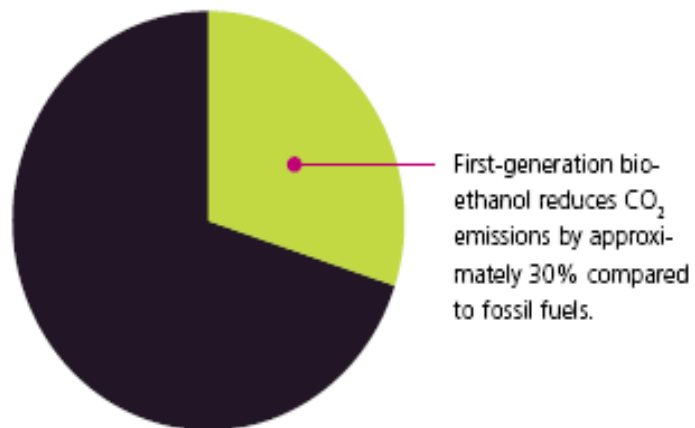

Second-generation bioethanol

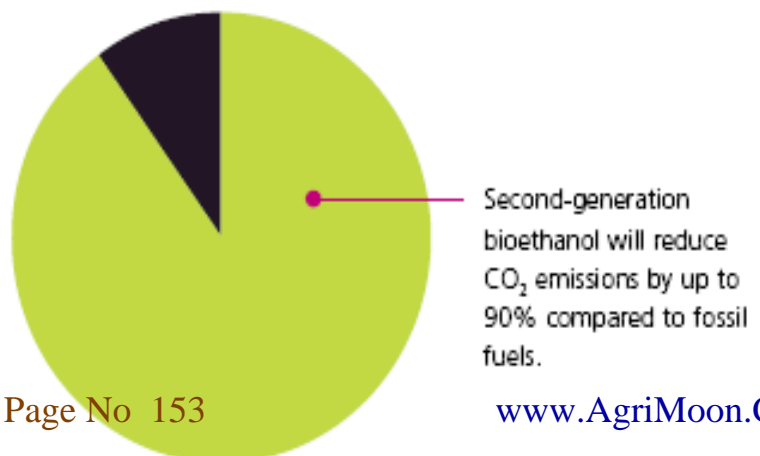

Renewable Energy

ethanol plant. This figure is likely to increase as the technology develops. It is expected that second-generation bio-ethanol will be able to reduce CO₂ emissions by as much as 90% compared to petroleum-based fuels.

Bioethanol production costs of the triticale cv. 'Modus' at the location Ihinger Hof dependency upon the previous crop and the crop production intensity (means of 1996/1997 and 1997/1998)

Species (cultivar)	Winter triticale (cv. 'Modus')					
	Pea			Winter grain		
	High	Medium	Minimum	High	Medium	Minimum
Previous crop						
Crop production intensity						
Grain dry weight (t ha ⁻¹)	9.1	7.6	6.2	8.5	5.8	4.3
Bioethanol conversion rate (l t ⁻¹)	461	459	468	454	456	463
Bioethanol yield (l ha ⁻¹)	4203	3505	2893	3840	2651	1968
<i>Grain production</i>						
Seed grain (DM ha ⁻¹)	91.7	91.7	91.7	91.7	91.7	91.7
Fertilization (DM ha ⁻¹)	224.7	120.0	97.2	263.3	91.5	66.8
Plant protection (DM ha ⁻¹)	305.8	279.1	23.7	284.1	262.8	23.7
Fixed machinery costs (DM ha ⁻¹)	322.8	388.3	326.4	327.3	406.3	318.7
Variable machinery costs (DM ha ⁻¹)	170.0	246.0	175.6	178.9	275.4	178.4
Labor costs (DM ha ⁻¹)	142.0	221.6	142.1	140.7	237.5	134.0
Insurance and interest costs (DM ha ⁻¹)	64.5	56.6	39.9	65.5	53.9	38.1
Σ (DM ha ⁻¹)	1321.5	1403.3	896.5	1351.5	1419.0	851.3
Grain production costs (DM l ⁻¹ of bioethanol)	0.31	0.40	0.31	0.35	0.54	0.43
<i>Bioethanol production</i>						
Capital costs	455.6	381.9	309.2	423.0	291.0	212.5
Staff, administration, maintenance	337.1	282.6	228.8	313.0	215.4	157.3
Enzymes and other chemicals	358.7	300.7	243.4	333.0	229.2	167.3
Process electricity costs	91.1	76.4	61.9	84.6	58.2	42.5
Process steam costs	419.1	351.3	284.5	389.2	267.7	195.5
Σ	1661.6	1392.8	1127.8	1542.8	1061.4	775.0
Conversion costs (DM l ⁻¹ of bioethanol)	0.40	0.40	0.39	0.40	0.40	0.39
Total costs (DM ha ⁻¹)	2983.1	2796.1	2024.3	2894.3	2480.4	1626.3
Total costs (DM l ⁻¹ of bioethanol)	0.71	0.80	0.70	0.75	0.94	0.82

Primary Inputs	Input Costs	Total Requirements
Corn (bu)	39,727,273	0.334831
Water (gal)	1,819,091	0.015332
KwH Electricity	2,618,550	0.022070
Natural Gas (btu* bushel*alcohol yield)	16,552,813	0.139511
Enzymes	3,136,615	0.026436
Yeasts	1,438,462	0.012124
Chemicals: processing and antibiotics	1,307,487	0.011020
Chemicals: boiling and cooling	327,436	0.002760
Denaturants	2,287,538	0.019280
Waste management	1,089,364	0.009181
Maintenance	756,909	0.006379
Transportation (rail only)	10,062,500	0.084809
All debt service costs	7,173,166	0.060457
All other unspecified	4,600,000	0.038770
Depreciation (Simple - straight 10 years)	7,346,000	0.061914

Production of Bio fuel (Ethanol)

Ethanol can be commercially produced by a variety of methods. The fermentation method is the one, which make use of naturally occurring renewable raw materials. Any material, which is capable of being fermented by enzymes, can serve as a source for ethanol production.

There is an abundance of farm crops/residues which can be of being used as raw materials in the fermentation process leading to ethanol production. Starch based feed stock include a variety of cereals, grains and tubers like cassava, yam, sweet potato etc. Starchy feed stocks can be hydrolyzed to get fermentable sugar syrup and give an average yield upto 42 litres of ethanol per 100 kg of feed stock.

General production process

The starch bearing materials are steamed for one to two hours at two to three atmospheric pressures to gelatinize the starch present. The resultant pulp is cooled to about 50°C and an equal volume of water and 10 per cent malt is added. The mixture is allowed to stand for a short while, when the starch is converted to dextrin. The

Renewable Energy

temperature is gradually raised to about 50°C while dextrin is converted first to maltose and then to dextrose.

Yeast is then added to the liquid mash and fermentation is allowed to proceed for a couple of days. The yeast converts sugar into ethanol. The ethanol water mixture is sent through additional distillation columns where ethanol concentration is increased to 190 proof (95 per cent ethanol). This in turn is dried through an extra active distillation process to yield 200 proof ethanol.

Lecture –20

Biofuels –Importance-transport sector –demand and growth of biofuels

Bio-fuel is another product from biomass. In 1930 and during the Second World War, many countries converted waste agricultural products to alcohol for use in automobiles, as 10-15 per cent blends with gasoline or as entire fuel. Traditionally, alcohol for industrial use is manufactured from molasses. Grains, grapes or other fruits, vegetables such as potatoes, starchy roots like cassava, mahua, flowers and palm juice may be used depending on their value in relation to human and animal foodstuff. Biofuel such as alcohol possesses most of the desirable attributes of source of energy. It is available throughout the world from all manners of raw materials. Indeed, any organic matter may be considered as a suitable source. It may readily be produced from waste portions of crops grown for food and other purposes, such as paddy straw, sorghum stalk, molasses and saw dust, or from crops specially grown for the purpose, such as cassava.

Combat Energy Crisis

We are facing the dangers of an energy crisis due to the depletion of traditional fuel sources such as coal, petroleum, and the like. Over the past few years, there has been an increasing awareness and acceptance of bio fuels as a viable potential substitute for petroleum. With several energy-related organizations, businesses, and governing bodies starting to recognize the importance of bio-based products and bio-energy, we are likely to see more legislation in favor of these new environmentally friendly commodities.

Reduce Greenhouse Effect

Bio-fuels promise to address some of the growing concerns about our environment, particularly global warming and the harmful effect of greenhouse gases. The planet's well-being, along with that of every individual, is at stake if we do not explore alternative paths. Changing our behavior, and thus, energy consumption to “cleaner” carbon-neutral alternative fuels like bio diesel is not just an alternative--it is essential.

Fuel Environmentally Friendly Cars

Consumers today are increasingly making “environmentally friendly” choices, including those regarding which automobiles they buy. Engines that run on bio diesel fuel or a blend of petro diesel and bio diesel are being manufactured in response to this new consciousness and desire for “green” transportation. Additionally, the automobile industry is now offering hybrid vehicles that operate on a combination of fuel and electricity. However, there is a market need for an increasing number of service stations that carry the alternative bio-fuel products and recharging if these choices are to succeed.

Break Foreign Oil Dependence

Breaking the dependence on foreign oil is another compelling reason to develop alternative energy sources. What is certain is that global energy needs, at both the industrial and personal levels, will continue to grow exponentially. Therefore, we need a sustainable, renewable option that we can depend on to continue to progress and to keep our planet alive and well.

Bio-fuels not only provide the answer to meeting our future energy needs, but respond to other societal challenges we face, as well. Such fuels offer many economic benefits and environmental.

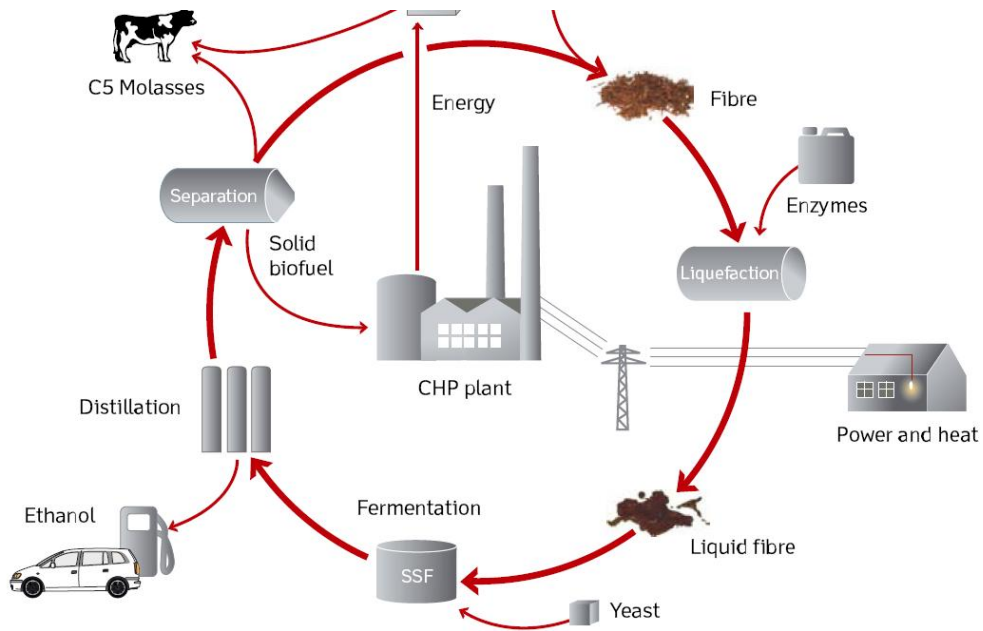

Lecture-21

Basics of Solar Photovoltaics

Photovoltaics (PV)

Photovoltaics (PV) comprise the technology to convert sunlight directly into electricity. The term “photo” means light and “voltaic,” electricity. A photovoltaic (PV) cell, also known as “solar cell,” is a semiconductor device that generates electricity when light falls on it. Although the French scientist Edmund Becquerel observed photovoltaic effect in 1839, it was not fully comprehensible until the development of quantum theory of light and solid state physics in early to middle 1900s. Since its first commercial use in powering orbital satellites of the US space programs in the 1950s, PV has made significant progress with total U.S. photovoltaic module and cell shipments reaching \$131 million dollars in 1996. While most PV cells in use today are silicon-based, cells made of other semiconductor materials are expected to surpass silicon PV cells in performance and cost and become viable competitors in the PV marketplace. This paper surveys the major types of PV cell materials including silicon- and non-silicon-based materials, providing an overview of the advantages and limitations of each type of materials.

Photovoltaic and Photovoltaic Cells

When sunlight strikes a PV cell, the photons of the absorbed sunlight dislodge the electrons from the atoms of the cell. The free electrons then move through the cell, creating and filling in holes in the cell. It is this movement of electrons and holes that generates electricity. The physical process in which a PV cell converts sunlight into electricity is known as the photovoltaic effect. One single PV cell produces up to 2 watts of power, too small even for powering pocket calculators or wristwatches. To increase power output, many PV cells are connected together to form modules, which are further assembled into larger units called arrays. This modular nature of

Fundamentals of Photovoltaic Materials

PV enables designers to build PV systems with various power output for different types of applications. A complete PV system consists not only of PV modules, but also the “balance of system” (BOS) - the support structures, wiring, storage, conversion devices, etc. i.e. everything else in a PV system except the PV modules.

Two major types of PV systems are available in the marketplace today: flat plate and concentrators. As the most prevalent type of PV systems, flat plate systems build the PV modules on a rigid and flat surface to capture sunlight. Concentrator systems use lenses to concentrate sunlight on the PV cells and increase the cell power output. Comparing the two systems, flat plate systems are typically less complicated but employ a larger number of cells while the concentrator systems use smaller areas of cells but require more sophisticated and expensive tracking systems. Unable to focus diffuse sunlight, concentrator systems do not work under cloudy conditions. Types of PV cell materials PV cells are made of semiconductor

materials. The major types of materials are crystalline and thin films, which vary from each other in terms of light absorption efficiency, energy conversion efficiency, manufacturing technology and cost of production. The rest of the paper discusses the characteristics, advantages and limitations of these two major types of cell materials.

Converting Photons to Electrons

The solar cells that you see on calculators and satellites are photovoltaic cells or modules (modules are simply a group of cells electrically connected and packaged in one frame). Photovoltaics, as the word implies (photo = light, voltaic = electricity), convert sunlight directly into electricity. Once used almost exclusively in space, photovoltaics are used more and more in less exotic ways. They could even power our houses.

Photovoltaic (PV) cells are made of special materials called semiconductors such as silicon, which is currently the most commonly used. In fact, Over 95% of the solar cells produced worldwide are composed of the semiconductor material silicon (Si). Basically, when light strikes the cell, a certain portion of it is absorbed within the semiconductor material. This means that the energy of the absorbed light is transferred to the semiconductor. The energy knocks electrons loose, allowing them to flow freely. PV cells also all have one or more electric fields that act to force electrons freed by light absorption to flow in a certain direction. This flow of electrons is a current, and by placing metal contacts on the top and bottom of the PV cell, we can draw that current off to use externally. For example, the current can power a calculator. This current, together with the cell's voltage (which is a result of its built-in electric field or fields), defines the power (or wattage) that the solar cell can produce.

1. Crystalline Materials

1.1 Single-crystal silicon

Single-crystal silicon cells are the most common in the PV industry. The main technique for producing single-crystal silicon is the Czochralski (CZ) method. High-purity polycrystalline is melted in a quartz crucible. A single-crystal silicon seed is dipped into this molten mass of polycrystalline.

Fundamentals of Photovoltaic Materials

Slowly from the melt, a single-crystal ingot is formed. The ingots are then sawed into thin wafers about 200-400 micrometers thick (1 micrometer = 1/1,000,000 meter). The thin wafers are then polished, doped, coated, interconnected and assembled into modules and arrays. A single-crystal silicon has a uniform molecular structure. Compared to non-crystalline materials, its high uniformity results in higher energy conversion efficiency is the ratio of electric power produced by the cell to the amount of available sunlight power i.e. power-out divided by power-in. The higher a PV cell's conversion efficiency, the more electricity it generates for a given area of

exposure to the sunlight. The conversion efficiency for single-silicon commercial modules ranges between 15-20%. Not only are they energy efficient, single-silicon modules are highly reliable for outdoor power applications. The average price for single-crystal modules is \$3.97 per peak watt in 1996. (Renewable Energy Annual 1997). About half of the manufacturing cost comes from wafering, a time-consuming and costly batch process in which ingots are cut into thin wafers with a thickness no less than 200 micrometers thick. If the wafers are too thin, the entire wafer will break in wafering and subsequent processing. Due to this thickness requirement, a PV cell requires a significant amount of raw silicon and half of this expensive material is lost as sawdust in wafering.

1.2 Polycrystalline silicon

Consisting of small grains of single-crystal silicon, polycrystalline PV cells are less energy efficient than single-crystalline silicon PV cells. The grain boundaries in polycrystalline silicon hinder the flow of electrons and reduce the power output of the cell. The energy conversion efficiency for a commercial module made of polycrystalline silicon ranges between 10 to 14%. A common approach to produce polycrystalline silicon PV cells is to slice thin wafers from blocks of cast polycrystalline silicon. Another more advanced approach is the “ribbon growth” method in which silicon is grown directly as thin ribbons or sheets with the approach thickness for making PV cells. Since no sawing is needed, the manufacturing cost is lower. The most commercially developed ribbon growth approach is EFG (edge-defined film-fed growth). Compared to single-crystalline silicon, polycrystalline silicon material is stronger and can be cut into one-third the thickness of single-crystal material. It also has slightly lower wafer cost and less strict growth requirements. However, their lower manufacturing cost is offset by the lower cell efficiency. The average price for a polycrystalline module made from cast and ribbon is \$3.92 per peak watt in 1996, slightly lower than that of a single-crystal module.

1.3 Gallium Arsenide (GaAs)

A compound semiconductor made of two elements: gallium (Ga) and arsenic (As), GaAs has a crystal structure similar to that of silicon. An advantage of GaAs is that it has high level of light absorptivity. To absorb the same amount of sunlight, GaAs requires only a layer of few micrometers thick while crystalline silicon requires a wafer of about 200-300 micrometers thick. Also, GaAs has a much higher energy conversion efficiency than crystal silicon, reaching about 25 to 30%. Its high resistance to heat makes it an ideal choice for concentrator systems in which cell temperatures are high. GaAs is also popular in space applications where strong resistance radiation damage and high cell efficiency are required. The biggest drawback of GaAs PV cells is the high cost of the single-crystal substrate that GaAs is grown on. Therefore it is most often used in concentrator systems where only a small area of GaAs cells is needed.

2 . Thin Film Materials

In a thin-film PV cell, a thin semiconductor layer of PV materials is deposited on low-cost supporting layer such as glass, metal or plastic foil. Since thin-film materials have higher light absorptivity than crystalline materials, the deposited layer of PV materials is extremely thin, from a few micrometers to even less than a micrometer (a single amorphous cell can be as thin as 0.3 micrometers). Thinner layers of material yield significant cost saving. Also, the deposition techniques in which PV materials are sprayed directly onto glass or metal substrate are cheaper. So the manufacturing process is faster, using up less energy and mass production is made easier than the ingot-growth approach of crystalline silicon. However, thin film PV cells suffer from poor cell conversion efficiency due to non-single crystal structure, requiring larger array areas and increasing area-related costs such as mountings. Constituting about 4% of total PV module shipments of US\$4, the PV industry sees great potentials of thin-film technology to achieve low-cost PV electricity. Materials used for thin film PV modules are as follows: the material, how much of the sunlight can be successfully converted into electricity is measured by the concept of energy conversion efficiency.

2 . 1 Amorphous Silicon (a-Si)

Used mostly in consumer electronic products which require lower power output and cost of production, amorphous silicon has been the dominant thin-film PV material since it was first discovered in 1974. Amorphous silicon is a non-crystalline form of silicon i.e. its silicon atoms are disordered in structure. A significant advantage of a-Si is its high light absorptivity, about 40 times higher than that of single-crystal silicon. Therefore only a thin layer of a-Si is sufficient for making PV cells (about 1 micrometer thick as compared to 200 or more micrometers thick for crystalline silicon cells). Also, a- Si can be deposited on various low-cost substrates, including steel, glass and plastic, and the manufacturing process requires lower temperatures and thus less energy. So the total material costs and manufacturing costs are lower per unit area as compared to those of crystalline silicon cells. Despite the promising economic advantages, a-Si still has two major roadblocks to overcome. One is the low cell energy conversion efficiency, ranging between 5-9%, and the other is the outdoor reliability problem in which the efficiency degrades within a few months of exposure to sunlight, losing about 10 to 15%. The average price for a a-Si module cost about \$7 per watt in 1995.5

2 . 2 Cadmium Telluride (CdTe)

As a polycrystalline semiconductor compound made of cadmium and tellurium, CdTe has a high light absorptivity level -- only about a micrometer thick can absorb 90% of the solar spectrum. Another advantage is that it is relatively easy and cheap to manufacture by processes such as high-rate evaporation, spraying or screen printing. The conversion efficiency for a CdTe commercial module is about 7%, similar to that of a-Si. The instability of cell and module performance is one of the major drawbacks of using CdTe for PV cells. Another disadvantage is that cadmium is a toxic substance. Although very little cadmium is used in CdTe modules, extra precautions have to be taken in manufacturing process.

2.3 Copper Indium Diselenide (CuInSe₂, or CIS)

A polycrystalline semiconductor compound of copper, indium and selenium, CIS has been one of the major research areas in the thin film industry. The reason for it to receive so much attention is that CIS has the highest “research” energy conversion efficiency of 17.7% in 1996 is not only the best among all the existing thin film materials, but also came close to the 18% research efficiency of the polycrystalline silicon PV cells. (A prototype CIS power module has a conversion efficiency of 10%.) Being able to deliver such high energy conversion efficiency without suffering from the outdoor degradation problem, CIS has demonstrated that thin film PV cells are a viable and competitive choice for the solar industry in the future. CIS is also one of the most light-absorbent semiconductors of 0.5 micrometers can absorb 90% of the solar spectrum. CIS is an efficient but complex material. Its complexity makes it difficult to manufacture. Also, safety issues might be another concern in the manufacturing process as it involves hydrogen selenide, an extremely toxic gas. So far, CIS is not Fundamentals of Photovoltaic Materials commercially available yet although Siemens Solar has plans to commercialize CIS thin-film PV modules.

Heat Transfer of Solar PV Panels

Because solar PV panels interact with their environment and their ϵ is so low, they passively absorb about 80% of the incoming solar irradiance as heat. This would not be such a problem if not for a 0.5% efficiency loss of the solar PV panels associated with a 1°K increase of the cell temperature. Because the highest temperatures of solar PV panels recorded are about 70 °C, this efficiency loss can be very noticeable, especially true for yesterday’s PV arrays that have such a low efficiency to begin with. Therefore, heat transfer plays an important role in the actual output of PV arrays. The three modes of heat transfer are involved with the solar PV array. The main energy input is solar irradiance in the form of shortwave radiation. The solar panel undergoes heat removal by convection, radiation, and conduction. However, the heat conducted is negligible because of the small contact area between the solar array and the its structural framework. The heat removed from the panel is in the form of long wave radiation due to the much colder temperature of the panel compared to the Sun. A schematic of this heat transfer mechanism is shown. It is worth noting that some solar arrays have an anti-reflection coating to decrease reflection losses and increase actual solar irradiance incident on the panel

The temperature of each individual PV cell is a function of its materials, configuration, time of day, rotation of the Earth and environmental factors such as wind, temperature, cloud cover and humidity. To determine the temperature of the solar PV panel a comprehensive heat transfer analysis must be performed.

Cooling Ducts

Renewable Energy

Brinkworth and Sandberg [2006] calculated the optimal length (L), the hydraulic diameter (Dh), and the width (H) of a cooling duct attached to the back of a solar PV panel which would reduce the most heat. They accomplished this by simultaneously solving the external and internal heat transfer equations. The external equation represents the heating of the surroundings from the front of the panel while the internal equation represents the heat transferred into the cooling duct. Their model was validated with measurements from a full-scale rig. Factors influence the temperature of the PV side of the duct are include radiation losses, and decreasing coefficients of heat transfer until the flow becomes fully developed.

Lecture-22

Recent trend in solar drying-Solar Tunnel drier

In India, Only 2-3 % of agricultural produce is being processed. Reduction of post harvest losses is inevitable. According to FAO reports, Crop loss accounts about 5-10 % (Paddy alone during Harvesting and Marketing : 30-50%),Fruits and vegetables is about 10 to 30 %, Pulses 8-10 %, Food and agricultural Commodities loss is about 20-50%.Drying process alone can reduce post harvest loss of 2-3 %. Uniform drying and quality of product is essential for better marketability. Reduction of fossil fuel usage and dependence of conventional power for drying process. Utilization of renewable energy is essential to reduce GHG emissions. Effective drying mechanism is needed for the hour for enhancing value of agro-produce. Our country is blessed with abundant solar energy available for more than 300 days in a year.

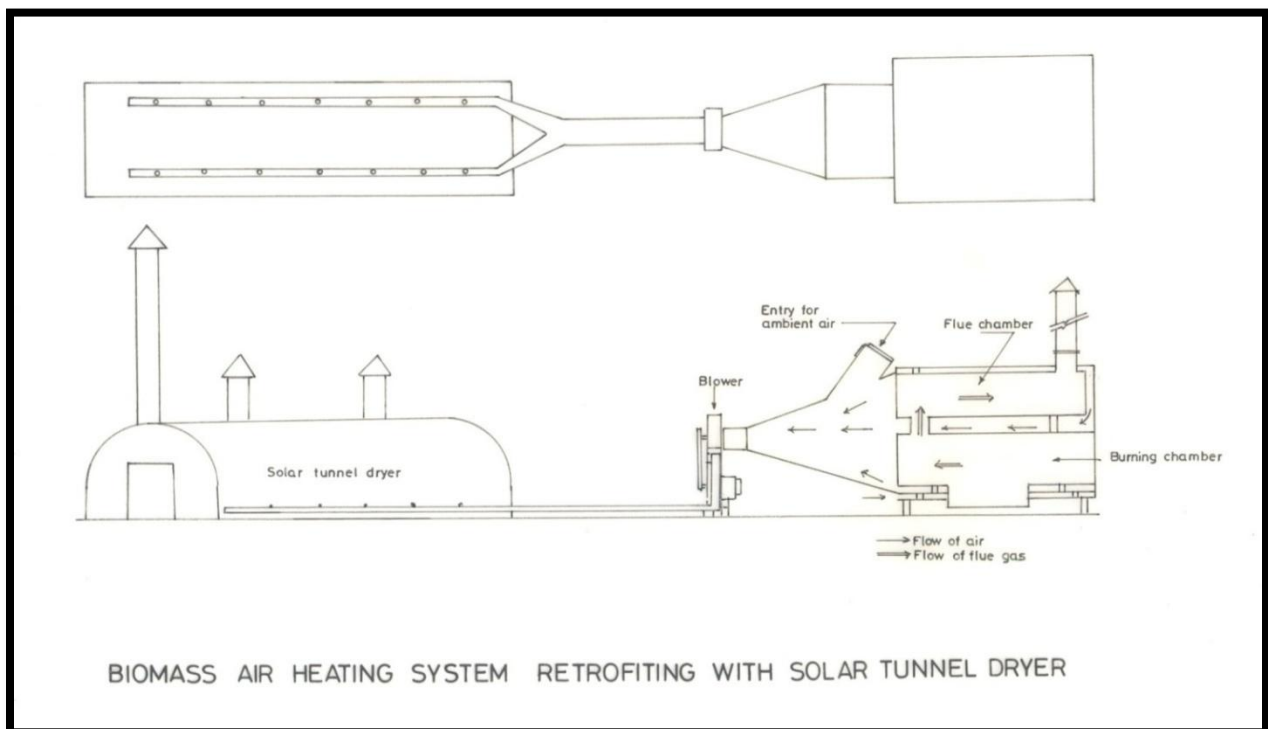

System specification

Solar tunnel drier utilizes solar thermal energy for drying applications. Its working principle is based on green house gas effect. Studies illustrates that a solar tunnel drier of 0.5 to 1.5 tonnes of product capacity occupy a size of 18.0 m x 3.75 m x 2.0 m. The system possesses semi-cylindrical tunnel structure with hoops and laterals. Solar collector material is of UV stabilized polyethylene with 200 μm thickness. Absorber surface is of cement concrete flooring with special black coating and is provided with equi-spaced chimney for natural ventilation.

Renewable Energy

Temperature boosted upto 20-25°C than ambient in this drier. Drying time is reduced up to 50% and labour requirement is also reduced to 40 % than conventional drying.

Following figures gives clear understanding about solar tunnel drier.



Drying Parameters of various agro products

Products	Temp °C	Initial moisture content %	Desired moisture content%	Drying Time (Days)	
				Open Sun Drying	Solar dryer
COCONUT	65	55	6 - 7	7-10	3-4
ARECANUT	70	70	12-14	6	3
COCOA	60	79.6	7.5-8.5	14	6
CHILLY	40-45	80	10	4-5	2

Control measures

Required instruments need to be provided to control the conditions and drying parameters of various agro-products at different temperature at different seasons and to match the integration of Solar dryer and Biomass hot air generation systems. Controlling and monitoring systems have to be paneled to drying the products by solar energy mode during the day hours and by biomass hot air generation system during the night hours. Each and every agro-product needs certain quality which is induced by different temperature and relative humidity. Regulating the drying parameters can be possible thro' instrumentation. As the natural exhaust system differs with respect to time, it is important to have controlled condition to regulate the drying parameters as well.

Lecture – 23

Solar driers – principles – types

Conventional method of drying is to spread the material in a thin layer on ground and let it exposed to the sun. Such a method has various disadvantages like,

- Accumulation of dust and harms due to insects
- Wastage of material due to birds
- Non uniform drying due to varying intensity of sun
- Larger area required for drying

All these difficulties are removed by using solar drier. There are two types of solar driers.

Natural convection solar drier

Natural air-drying is an in bin drying system with the following typical characteristics:

- Drying process is slow, generally requiring 4 to 8 weeks.
- Initial moisture content is normally limited to 22 to 24%.
- Drying results from forcing unheated air through grain at airflow rates of 1 to 2 cfm/bu.
- Drying and storage occur in the same bin, minimizing grain handling.
- Bin is equipped with a full-perforated floor, one or more high capacity fans, a grain distributor and stairs
- Cleaning equipment is used to remove broken kernels and fines.



Description of Cabinet drier

It can be of fixed type and also of portable type. Generally it has an area of about 3 x 5 m² glass sheet fixed at the top at an angle of about 0 to 30°. Holes are provided at the bottom and at the topsides for airflow by natural convection. Wire meshed black tray is provided to the material to be dried.

Forced convection solar dryer (Hot air system):

In these, the collectors are provided with duct. Generally, a duct of 2.5 cm depth is provided. It is made out of two plates welded together lengthwise. Cold air is blown through a blower into the collectors, which gets heated during the passage through it. The hot air thus available is then used for drying the products kept on the shelves of

Renewable Energy

driers. This hot air takes away the moisture of the products and is let out through a properly located outlet.

1. Absorber with ducting
2. Blower with motor and
3. Drying bin

Description

This drier has three main components viz., flat plate collector, blower and drying bin. The area of the collector is 8m^2 . It is divided into 4 bays each having $2\text{m} \times 1\text{m}$ absorber area. The absorber is made out of 20 g. corrugated G.I. sheet and is painted with dull black colour. Another plain G.I. sheet placed 5 cm below the absorber plate creates air space for heating. This sheet is insulated at the bottom with glass wool and is supported at the bottom with another plain G.I. sheet. The absorber is covered at the top with two layers of 3 mm thick plain glass. The unit is supported on all sides with wooden scantling and is placed at 11° to the horizontal facing south. Baffle plates are provided in the air space. The air space is open at the bottom to suck atmospheric air and at the top it

is connected to a duct leading to suction side of the blower. The blower is of $80\text{m}^3/\text{min}$, capacity run by 3HP electric motor. The delivery side of the blower is connected to the plenum chamber of a circular grain holding bin.

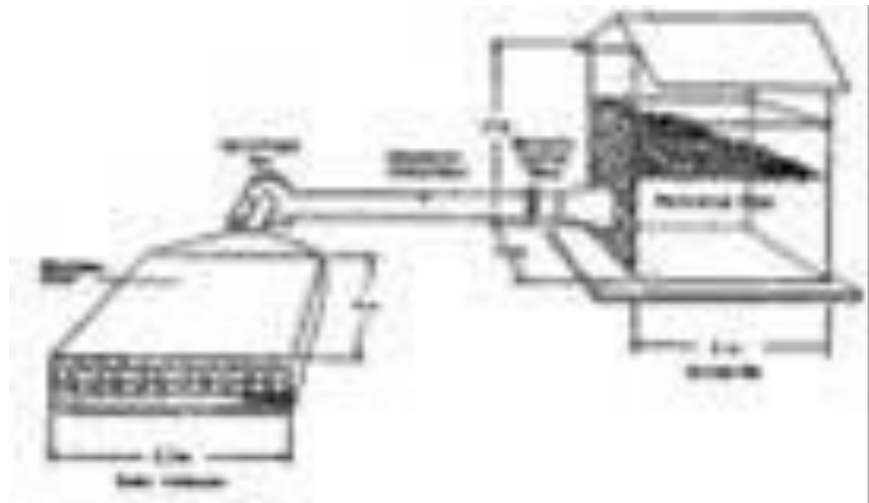

Forced Convection Solar Drier for Drying of Grains

For drying high moisture paddy the solar drier can be used. The different components of the drier are air heater, air ducts and blower and grain drying chamber. The flat plate collector used for heating the air has an efficiency of 60% and rise in ambient air temperature is 13°C . Freshly harvested paddy can be dried and it may take about 7-8 hours to bring the moisture content from 30% to 16% (d.b.). After drying the grains, the milling quality can be tested. The use of solar air heater for drying of grains

Renewable Energy

indicates that 10-15°C rise in the temperature of the air is enough to reduce the relative humidity of the air to 60% or less which is quite useful for drying of cereal grains.

To the level consists of safe moisture content for storage 500 kg of paddy could be dried from 30 to 40 % moisture content in a period of 6 hours on bright sunny day by using air flow rate of 4 m³/min with temperature rise 8-10°C.

Solar drier consists of air heater, blower drying chamber, air distribution system and thermal storage system. The heated air is blown to drying chamber by blowers of the centrifugal type to handle large quantity of air. Batch type or continuous flow type drying chamber artificially creates the necessary radiation to reduce moisture. Hot air from the collector is sucked by a blower through the inlet pipe and is being forced into the drying chamber. An auxiliary heating system to supplement heat requirement may be arranged. This type of auxiliary systems and thermal storage systems for collecting extra energy during daytime, take care of the night operations.

The heat required Q in kcal/hr

$$Q = V \times \rho \times C_p \times \Delta T \quad \text{-----} \quad (1)$$

Where V = air flow rate, m³/hr
 ρ = density of air, kg/ m³
 C_p = the specific heat of air, and
 ΔT = temperature rise.

Moisture content assessed per tonne of paddy (m) for drying pre-boiled paddy, yield the volume of air to be handled V from

$$m \times \text{latent heat} = V \times \rho \times C_p \times \Delta T \times \text{efficiency} \quad \text{-----} \quad (2)$$

The volume of rock pile required V' for thermal storage of heat energy Q is

$$V' = \frac{Q}{\rho' C_p' \Delta T'} \quad \text{-----} \quad (3)$$

Where ρ' = density of rock
 C_p' = specific heat of rock
 $\Delta T'$ = temperature increase in rock.

Lecture –24

Solar PV systems – Principle-water pumping applications

Solar photovoltaic systems are energy conversion systems which convert solar energy into electrical energy. Solar photovoltaic system operates on the basis of the photovoltaic effect on a silicon junction diode designed to facilitate the collection of usable magnitudes of electricity. Usually of the order of 1.5A at 0.5V. Such a junction diode is called a solar cell. Number of cells are string up in series to generate power at usable voltages. The solar photovoltaic system comprises of three main sub-systems, viz., solar panel, control unit and battery. The solar panel contains solar cells which produce electricity when exposed to sunlight. The electricity generated charges the battery / batteries and the power stored can be used at a later time. The control unit regulates the charging and discharging of the battery. The application has to be optimized according to the load profile and the geographic location in which it is used. The load is the most important choice from the user's point of view. There are more than five applications in practice. Thus are the solar lantern, solar water pumping system , solar street light, solar sprayer, solar insect trap and solar powered tricycle.

Solar lantern

The solar lantern is a portable solar photovoltaic lighting system which provides about 2-3 hours of light per night based on the days charge. The lantern is designed to be similar to a hurricane lantern in its shape and about a hundred times brighter. The system consists of 5 watt tube which is driven at a specially designed frequency choke / inverter operating at a frequency above 30 Khz. As these lanterns are portable, a person as per his requirements and convenience can carry it. As the battery is a sealed maintenance free type, no special maintenance is required except for daily charging.

Fig 1.Solar lantern

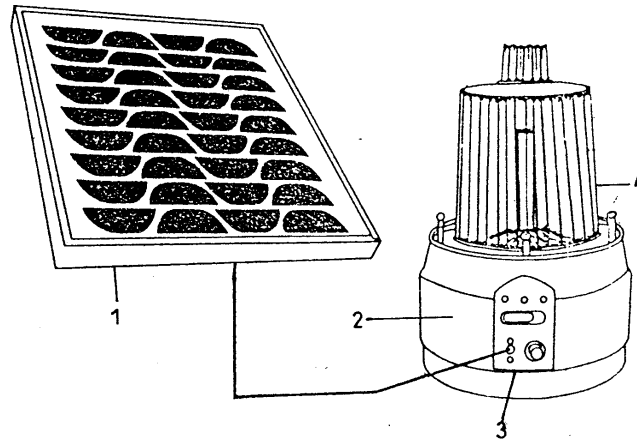

1. Solar module 2. Battery
3. Control circuits 4. Lamp

Solar water pumping system

A solar photovoltaic water pumping system, essentially consists of a SPV panel / array directly powering a water pump. The water pumped during the day can be stored in storage tanks for use during night. The generated electricity from the panel is fed to the pump through a switch and a 3 phase inverter, in case of AC submersible pumpset. Normally, no storage batteries are provided as the water can be stored in storage tanks, if required.

Features :

- Modular and hence easily field upgradable.
- Noise and pollution free operation
- Does not require any fuel
- Uses the abundantly available sunlight
- Simple to install, operate and maintain
- Designed to give optimum output even during low sunshine period

Fig :2. Solar water pumping system



Applications

- Minor irrigation
- Drinking water for unelectrified villages and remote locations
- Horticulture, poultry farming, silviculture and pisciculture
- Farm house
- Wild life sanctuary
- Tourist resort

Lecture –25

Solar water heaters – Principle and applications

Solar energy has several advantages over the other energy sources. It is inexhaustible, it is free from any pollution and unlike fossil fuels, transformation of solar energy does not produce any toxic by-products. No nation can put an embargo on its supply. So, if a means could be found to make efficient use of solar energy, it would mean a continuing free supply of energy which would not degrade our environment and also reduce our dependence on non-renewable sources of energy.

The estimated solar energy potential in the country is 200 MW/sq.km and can be utilized both for thermal and electrical applications. The solar thermal applications include hot water systems for industrial, commercial and domestic use besides solar cookers, solar dryers, solar stills and solar photovoltaic cell operated applications aimed at producing power.

Solar Energy Availability in India

Total area of land in India	=	$3.28 \times 10^{11} \text{ m}^2$
Total number of sun shine days in a year	=	300 (assumed)
Average solar isolation in India	=	500 W / m^2
No. of sunshine hours in a day	=	5 hours
Total solar radiation received in a day	=	$3.28 \times 10^{11} \times 500 \times 5 \times 3600 \text{ J}$
	=	$2.952 \times 10^{15} \text{ J}$
	=	$2.952 \times 10^9 \text{ MJ / day}$
Total solar isolation received in a year in India	=	$2.952 \times 10^9 \times 300$
	=	$8.856 \times 10^{11} \text{ MJ}$

If 1% of land area is used to harness solar energy with thermal efficiency of 10%

Solar energy available for use in a year	=	$8.856 \times 10^{11} \times 0.01 \times 0.1$
Solar energy available for use in India	=	$8.856 \times 10^8 \text{ MJ}$

Solar Thermal Devices

The solar water heater consists of a solar collector, insulated stainless steel tank and piping connections. The total system can be mounted on the roof top, on one side the piping connects it to the overhead tank and on the other side to the usage points. The

smallest capacity available is 100 litres per day at 60⁰ C temperature, suitable for a family of 4-6 members.

Solar water heater

The solar water heating systems come with a solar collector of 25 sq. m area for solar tank of 100 litre capacity. It occupies an area of 35 sq. ft on the roof top. The water is loaded in the daytime and is stored in the storage tank for a period of 48 hours. This system can be connected to bathrooms and kitchen. Generally, the life of the system is about 15 years and it requires no maintenance.

The collector is having 20 gauge G.I. corrugated sheet as absorber with 12 mm. G.I. pipes as heat exchanger laid in the corrugations of the sheet in serpent fashion. The absorber and the pipes are painted black and embedded in a wooden box insulated at the bottom and sides. The ends of the pipe are connected to the insulated storage drum which is kept just above the collector. The collector is kept on an angle iron stand such that the flat plate is at 11° slope facing south. Hot water temperature is 55 - 63° C on a typical sunny day and heat loss due to over night storage is about 4 to 8°C.

Fig : solar water heater.

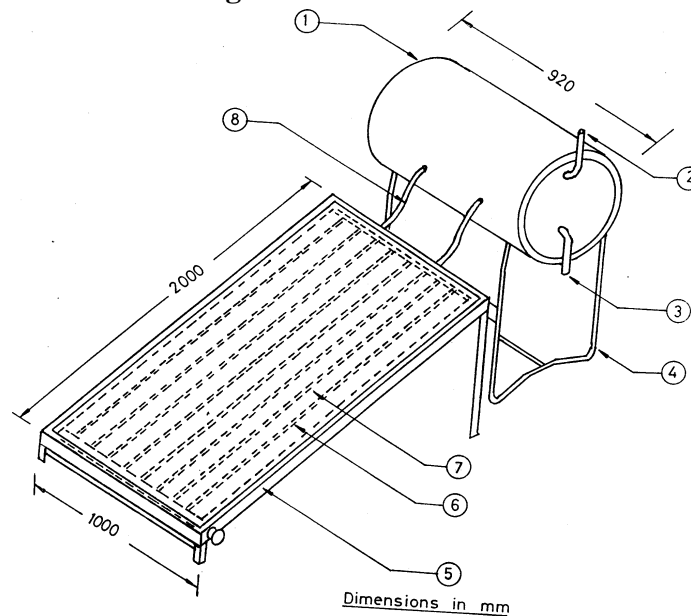

- | | |
|-------------------------|-----------------|
| 1. Insulated water tank | 2. Water inlet |
| 3. Water outlet | 4. Tank support |
| 5. Frame | 6. Liquid pipe |
| 7. Absorber | 8. Water line |

Renewable Energy

A solar collector is a device designed to absorb incident solar radiation and to transfer the energy to a fluid passing in contact with it. Utilization of solar energy requires solar collectors. There are two general types - the flat-plate collector and the concentrating (focusing) collector.

Solar collectors may be classified according to their collecting characteristics, the way in which they are mounted and the type of transfer fluid they employ.

(1) *Collecting characteristics:* A non-concentrating or 'flat-plate' collector is one in which the absorbing surface for solar radiation is essentially flat with no means for concentrating the incoming solar radiation. A concentrating or 'focusing' collector is one, which usually contains reflectors or employs other optical means to concentrate the energy falling on the aperture on to a heat exchanger of surface area smaller than the aperture.

(2) *Mounting:* A collector can be mounted to remain stationary, be adjustable as to tilt angle (measured from the horizontal) to follow the change in solar declination or be designed to track the sun. Employing either an equatorial mounting or an altazimuth mounting, for the purpose of increasing the absorption of the daily solar irradiation does tracking.

(3) *Types of fluid:* A collector will usually use either a liquid or a gas as the transfer fluid. The most common liquids are water or a water-ethylene glycol solution. The most common gas is air.

General Description of Flat-plate Collectors

Flat-plate solar collectors may be divided into two main classifications based on the type of heat transfer fluid used.

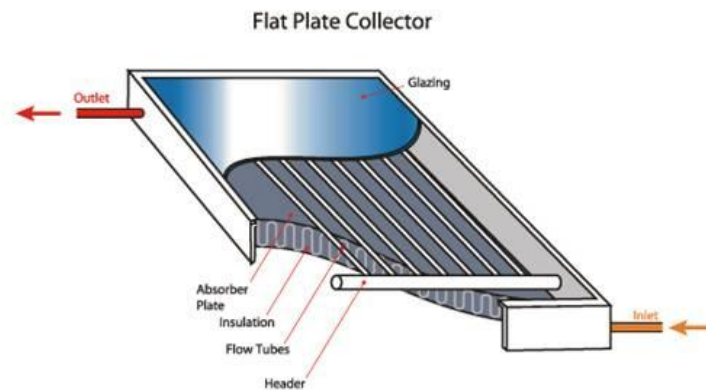

Fig 2. Flate plate collector

Liquid heating collectors are used for heating water and non-freezing aqueous solutions and occasionally for non-aqueous heat transfer fluids. Air or gas heating collectors are employed as *solar air heaters*.

The principal difference between the two types is the design of the passages for the heat transfer fluid.

The majority of the flat-plate collectors have five main components as follows:

- (i) A transparent cover which may be one or more sheets of glass or radiation transmitting plastic film or sheet.
- (ii) Tubes, fins, passages or channels are integral with the collector absorber plate or connected to it, which carry the water, air or other fluid.
- (iii) The absorber plate, normally metallic or with a black surface, although a wide variety of other materials can be used, particularly with air heaters.
- (iv) Insulation, which should be provided at the back and sides to minimize the heat losses.
- (v) The casing or container, which encloses the other components and protects them from the weather.

A Typical Liquid Collector

Fig.3 is a schematic representation of a typical flat-plate solar collector (plate and tube type). It basically consists of a flat surface with high absorptivity for solar radiation, called the absorbing surface. Typically a metal plate, usually of copper, steel or aluminum material with tubing of copper in thermal contact with the plates, is the most commonly used material. The absorber plate is usually made from a metal sheet 1 to 2mm in thickness, while the tubes, which are also of metal, range in diameter from 1 to 1.5 cm. They are soldered, brazed or clamped to the bottom (in some cases, to the top) of the absorber plate with the pitch ranging from 5 to 15cm. In some designs, the tubes are also in line and integral with the absorber plate. For the absorber plate, corrugated galvanized sheet is a material widely available throughout the world



Fig.3 .Flat Plate liquid collector

Lecture-26

Hydro- Energy conversion system

All forms of energy can be classified into one of two categories: kinetic energy or potential energy. Kinetic energy is the energy that an object has because of its motion relative to its surroundings. It has the ability to do work on other objects by applying a force to those objects in order to change its velocity. For example, a cue ball that is rolling across the table has kinetic energy relative to the other billiard balls on the table that are static. If the cue ball hits another ball, it applies a force to the second ball over a very small distance. This force changes the cue ball's velocity while it transfers energy to the static ball, and thus, it does work.

The other category of energy is potential energy. This is the energy that is stored in a system by virtue of forces between objects that are separated by some distance. If the objects are allowed to move under the influence of the force between them, then work is done as the force displaces the objects from their initial positions, and energy is transferred. A prime example of this is gravitational potential energy. A ball that is dropped from rest at some height above the Earth's surface will begin to accelerate downward as gravity pulls it. As the ball accelerates, gravity is working on it to convert its potential energy into kinetic energy (the ball's height decreases as its velocity increases). If the ball is dropped from a higher altitude, then gravity operates over a greater distance, thereby generating more kinetic energy, i.e. the gravitational potential energy of an object depends upon the height through which an object is allowed to fall.

Gravitational Potential Energy

Newton's Universal Law of Gravity tells us that the gravitational force between two objects depends upon the inverse of the square of the distance between the objects and is, therefore, not a constant force with displacement. However, if we limit the movements of the objects to small values compared to the total distance between them, then we can consider the force of gravity to be a constant. Objects falling near the surface of the Earth fall into this category. The distance between the center of the Earth and the center of any object near the surface is over 4,000 miles. If we limit the object to fall a distance of less than a mile, then the change in the force of gravity over that distance is less than .05%. Thus, we can take it to be a constant. In this situation, Newton's Universal Law of Gravity reduces to the expression:

$$F_{\text{gravity}} = \text{mass} \times \text{acceleration due to gravity near Earth} = \text{mass} \times 9.80 \text{ m/sec}^2$$

Since the force is a constant, the potential energy is merely this force multiplied by the distance through which the object falls. If we allow H to be the height through the object will fall, then the potential energy of the object is:

$$\text{P.E.} = F_{\text{gravity}} \times H = \text{mass} \times 9.80 \text{ m/sec}^2 \times H$$

Renewable Energy

For a hydroelectric dam, the object that is “falling” is water. The mass of the water that is falling is determined by how much volume it occupies. The relationship between the two is given by the formula $\text{mass} = \text{density} \times \text{volume}$. For fresh water, the density is 1 gm/cm^3 , which is equivalent to 1000 kg/m^3 . Thus, our formula for the potential energy of a volume of water V that falls through a height H is

$$\text{P.E.} = (9800 \text{ J/m}^4) \times VH$$

where J is the symbol for the unit of energy called the joule.

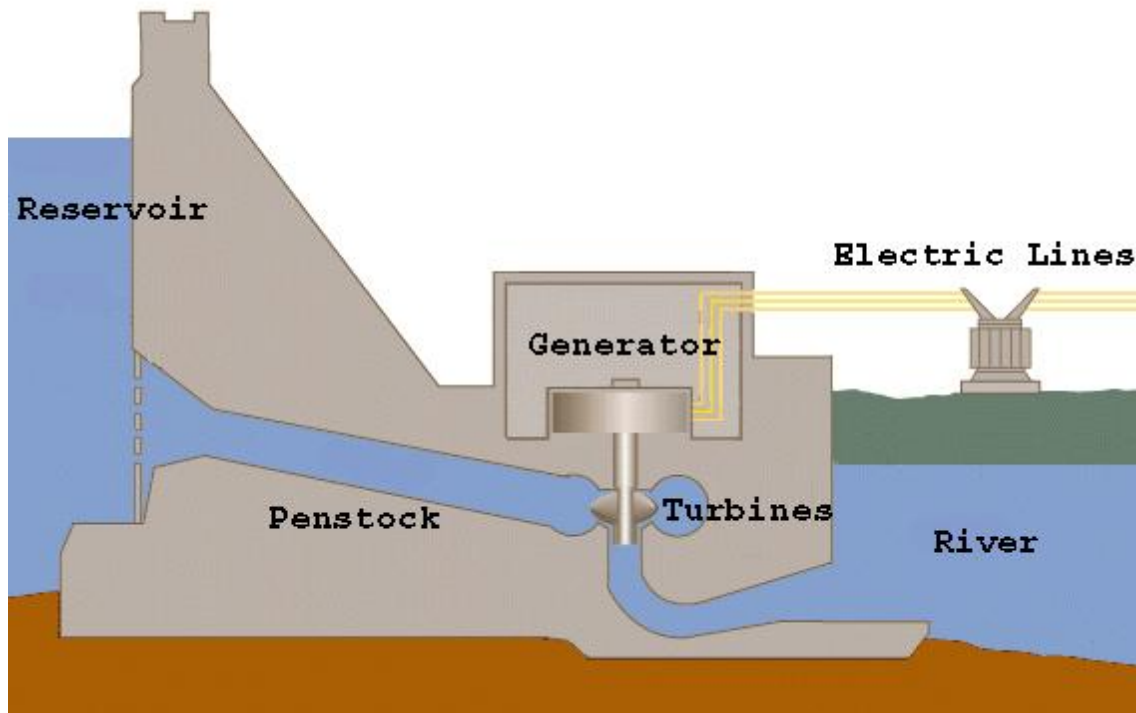

Figure : Diagram of a hydroelectric facility

When we write about the water “falling”, we are giving a somewhat false impression of how a hydroelectric dam works. Figure is a diagram of a conventional hydroelectric facility. As you can see, the water does not fall onto the turbine to turn it. Instead, the water near the bottom of the dam is forced by the pressure of the water above it past the turbines. While this is not the same as falling onto the turbines, it turns out that it is equivalent mathematically. Therefore, the formula that we derived above for potential energy is the one used for a dam, where H is the difference in heights between the surface of the water in the reservoir and the turbine.

Efficiency

This potential energy, though, will not be the actual amount of electrical energy that we can get out of the dam. This is because of the first and second laws of thermodynamics. The first law states that "Energy can neither be created nor destroyed; it can only be transferred from one form

Renewable Energy

to another." While this statement of the first law is the most common expression of it, it really does not say anything about how energy can be transferred. In mathematical terms, the first law is normally stated as

$$\Delta E = W + Q$$

Where, ΔE is the change in the energy of an object, W is the work done on the object, and Q is the heat added to the object. In laymen's terms, this means that the only way to change the energy of an object is to either do work on it or add heat to it (it should be noted that having the object do work on its surroundings, or allowing the object to give off heat, are equivalent to having negative values for W or Q).

The First Law of Thermodynamics tells us that the energy involved in any transfer must be conserved. This would seem to mean that we should never run out of energy and should pay no heed to anybody talking about an energy crisis. The problem is that this is not the only law that governs energy transfers. While the total amount of energy does not change, the second law of thermodynamics puts limits on the amount of usable energy that can be transferred. One of the consequences of this law is that the total amount of usable energy that comes out of any process will be less than the total amount of energy that went into the process. The difference between the total amount of energy input and the usable energy output is expended as waste heat.

This brings us to the issue of efficiency, which is a measure of the amount of usable energy that is generated during any type of transfer. If a transfer is very efficient, then the amount of usable energy that is generated is almost equal to the total amount of energy that went into the transfer. This means that very little waste energy will be produced. An inefficient transfer, conversely, is one in which most of the energy going into the process is converted to waste heat. For example, a fluorescent light bulb converts about 20% of the electrical energy that runs through it into visible light energy. While this may not sound like a very efficient transfer, it is much better than the 5% efficiency of an incandescent light bulb, which most people use.

When discussing the efficiency of a process, we have to make sure and not forget all of the transfers that might need to take place in order to get to the one under investigation. A great example of this occurs when comparing the efficiencies of electric and internal combustion engine powered cars. The efficiency of the electric motor in a car is about 90%, while the efficiency of the internal combustion engine is only about 25%. However, these efficiencies are not the only things that need to be considered when comparing the two devices. How is the electricity that charges the car created? Where does the gasoline come from that powers the internal combustion engine? What types of transmission systems does each car have? There are many steps and energy transfers that take place in getting each type of car to move, and each one of these has its own individual efficiency. For instance, the average coal burning electric plant is only about 30-35% efficient in generating electricity (some newer natural gas plants are closer to 50-60%). This fact greatly reduces the overall efficiency of an electric car. When we consider the

Renewable Energy

total efficiency, from getting the energy from its natural source to the car moving down the highway, we find that the electric car is only about 20% efficient, while the internal combustion engine automobile is about half that at 10%.

Turbine Generator

These same types of rules apply to a hydroelectric dam. Not all of the potential energy of the water behind the dam is realized. The water running through the pipes encounters drag forces from the pipe walls. The water hitting the turbines generates some heat, as does any type of collision. The water leaving the turbine still has some kinetic energy, which is energy not given to the turbine. Accounting for all of the energy losses in the system, the system is still about 80-90% efficient, which is one of the highest efficiencies for any type of electricity generating facility that we use in society today.

In this week's experiment, we are going to model this system in the laboratory. This type of generator can be purchased from scientific equipment supplies, along with probes that will measure the amount of electricity generated (the unit in Figure was purchased from Pasco Scientific). This experiment transfers the potential energy of water from a plastic container that is placed a height H above the generator to the kinetic energy of the moving turbine blades on the generator. The generator then transfers this kinetic energy to electrical energy by spinning a magnetic in the wire coil on the top of the generator. This electrical energy will be sent to a computer that will monitor the output. From the energy measured by the computer, we will plot the dependence of potential energy on height, as well as calculating the efficiency of energy transfer in the turbine generator.

As stated previously, the amount of gravitational potential energy that an object has should depend upon the height through which it is allowed to fall. Theoretically, this dependence should be linear, i.e. the amount of gravitational potential energy an object is equal to some constant times the height of the object. Therefore, if everything else in the system is linear, this means that the amount of electrical energy produced should depend linearly on the height of the water.



Figure : Turbine Generator

The other issue that we are going to investigate is the efficiency of the total energy transfer from gravitational potential energy to electrical energy. By plugging in the height of each individual run, this formula gives us the total amount of energy in the system at the start. The computer will measure the amount of electrical energy that is output by the generator. Thus, we should be able to compute the efficiency of the system using the formula:

$$\text{Efficiency} = (\text{electrical energy output}) / (\text{potential energy})$$
$$= (\text{electrical energy output}) / [(9800 \text{ J/m}^4) \times V H]$$

When using this formula in the lab, be sure that both the electrical energy output and the potential energy have the same units of energy. If you measure V in cubic meters and H in meters, then the units for potential energy should be in joules, which is a watt-second. Ask your instructor to make sure that you are using the proper units on your lab.

Pumped hydroelectric energy storage (PHES)

Pumped hydroelectric energy storage (PHES) is a mature technology that has been deployed for over a century.³ Examples of installed PHES systems as early as 1890 can be found in both Italy and Switzerland. PHES does not generate electricity, rather is a storage mechanism.⁴ PHES uses electricity to pump water uphill to be stored, then energy is later recaptured when the water released back down hill through a turbine. PHES systems are highly efficient, capable of reaching and surpassing 80-85% round-trip efficiencies. The scale of PHES this paper addresses is suited to the functional ability of the Francis turbine. The Francis turbine is capable of reversible operation, utilizing a single unit that acts as a motor-pump or a turbine-generator. Figure 2-3 shows a basic schematic of the PHES installation at Raccoon Mountain owned and operated by the Tennessee Valley Authority (TVA)

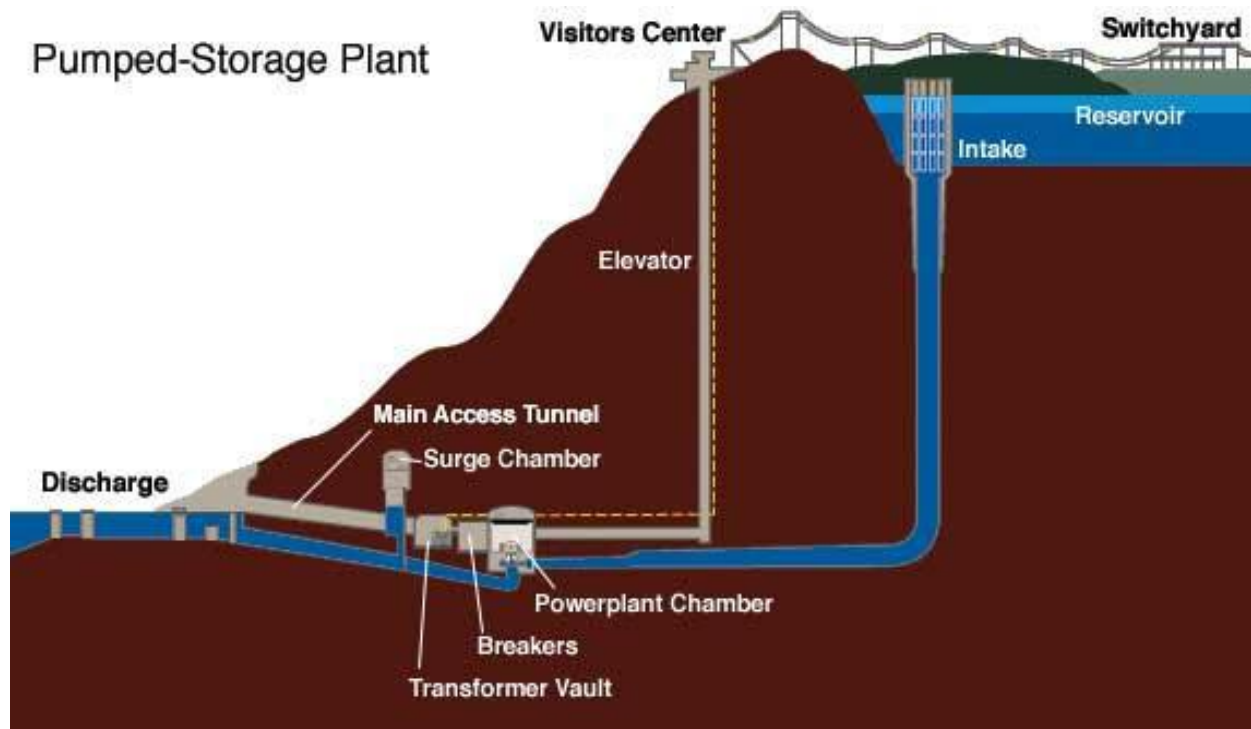

Figure : A basic schematic of the pumped hydro installation at Raccoon Mountain

Lecture-27.

Wind Energy

The power in the wind

The wind systems that exist over the earth's surface are a result of variations in air pressure. These are in turn due to the variations in solar heating. Warm air rises and cooler air rushes in to take its place. Wind is merely the movement of air from one place to another. There are global wind patterns related to large scale solar heating of different regions of the earth's surface and seasonal variations in solar incidence. There are also localised wind patterns due the effects of temperature differences between land and seas, or mountains and valleys. Wind speed generally increases with height above ground. This is because the roughness of ground features such as vegetation and houses cause the wind to be slowed. Wind speed data can be obtained from wind maps or from the meteorology office. Unfortunately the general availability and reliability of wind speed data is extremely poor in many regions of the world. However, significant areas of the world have mean annual wind speeds of above 4-5 m/s (metres per second) which makes small-scale wind powered electricity generation an attractive option. It is important to obtain accurate wind speed data for the site in mind before any decision can be made as to its suitability. Methods for assessing the mean wind speed are found in the relevant texts (see the 'References and resources' section at the end of this fact sheet).

The power in the wind is proportional to:

- Area of windmill being swept by the wind
- Cube of the wind speed
- Air density - which varies with altitude

The formula used for calculating the power in the wind is shown below:

Power = density of air x swept area x velocity cubed

$$P = \frac{1}{2} \cdot \rho \cdot A \cdot V^3$$

where, P is power in watts (W)

ρ is the air density in kilograms per cubic metre (kg/m³)

A is the swept rotor area in square metres (m²)

Wind for electricity generation Practical Action

V is the wind speed in metres per second (m/s)

Renewable Energy

The fact that the power is proportional to the cube of the windspeed is very significant. This can be demonstrated by pointing out that if the wind speed doubles then the power in the wind increases by a factor of eight. It is therefore worthwhile finding a site which has a relatively high mean wind speed.

Wind into watts

Although the power equation above gives us the power in the wind, the actual power that we can extract from the wind is significantly less than this figure suggests. The actual power will depend on several factors, such as the type of machine and rotor used, the sophistication of blade design, friction losses, and the losses in the pump or other equipment connected to the wind machine. There are also physical limits to the amount of power that can be extracted realistically from the wind. It can be shown theoretically that any windmill can only possibly extract a maximum of 59.3% of the power from the wind (this is known as the Betz limit). In reality, this figure is usually around 45% (maximum) for a large electricity producing turbine and around 30% to 40% for a wind pump, (see the section on coefficient of performance below). So, modifying the formula for 'Power in the wind' we can say that the power which is produced by the wind machine can be given by:

$$PM = \frac{1}{2} \cdot C_p \cdot \rho \cdot A \cdot V^3$$

where,

PM is power (in watts) available from the machine

C_p is the coefficient of performance of the wind machine

It is also worth bearing in mind that a wind machine will only operate at its maximum efficiency for a fraction of the time it is running, due to variations in wind speed. A rough estimate of the output from a wind machine can be obtained using the following equation;

$$PA = 0.2 A V^3$$

where,

PA is the average power output in watts over the year

V is the mean annual windspeed in m/s

Principles of wind energy conversion

There are two primary physical principles by which energy can be extracted from the wind; these are through the creation of either lift or drag force (or through a combination of the two). The difference between drag and lift is illustrated by the difference between using a spinnaker sail, which fills like a parachute and pulls a sailing boat with the wind, and a Bermuda rig, the

familiar triangular sail which deflects with wind and allows a sailing boat to travel across the wind or slightly into the wind. Drag forces provide the most obvious means of propulsion, these being the forces felt by a person (or object) exposed to the wind. Lift forces are the most efficient means of propulsion but being more subtle than drag forces are not so well understood. The basic features that characterise lift and drag are:

- Drag is in the direction of air flow
- Lift is perpendicular to the direction of air flow
- Generation of lift always causes a certain amount of drag to be developed
- With a good aerofoil, the lift produced can be more than thirty times greater than the drag
- Lift devices are generally more efficient than drag devices

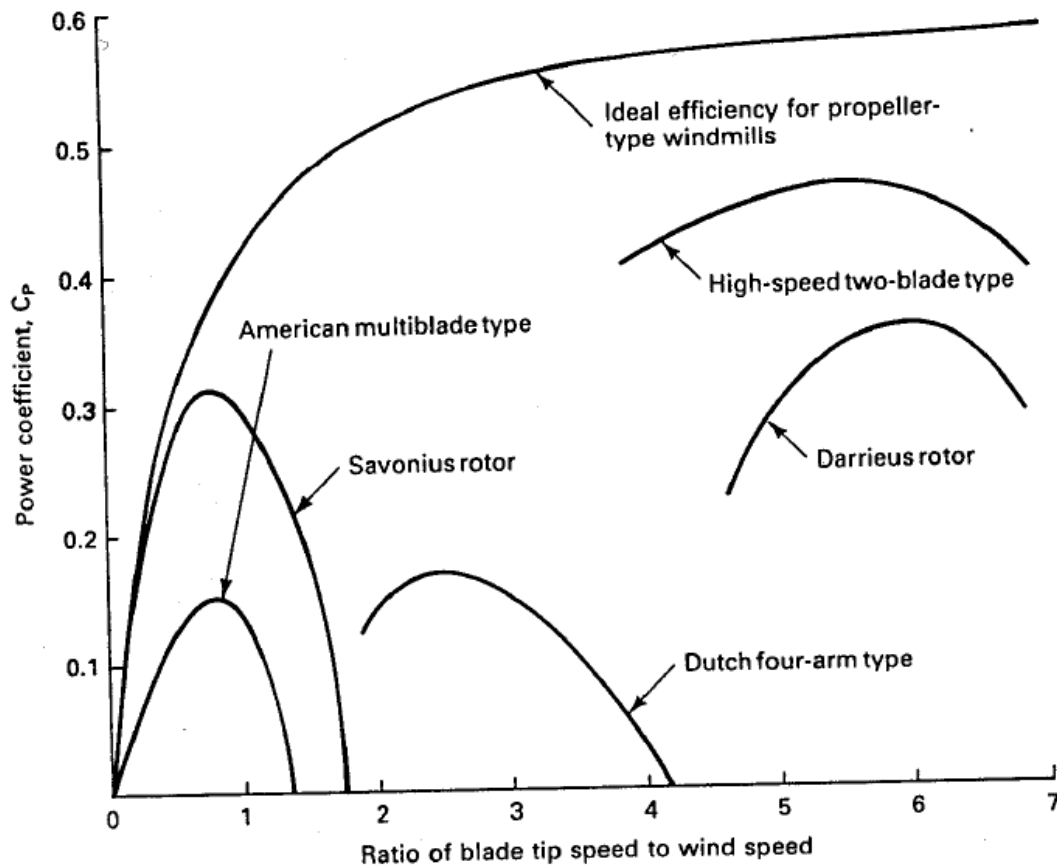

FIG. Performance of wind mill system.

Types and characteristics of rotors

There are two main families of wind machines: vertical axis machines and horizontal axis Wind for electricity generation Practical Action machines. These can in turn use either lift or drag forces to harness the wind. The horizontal axis lift device is the type most commonly used. In fact other than a few experimental machines virtually all windmills come under this category. There are several technical parameters that are used to characterise windmill rotors. The tip speed ratio is defined as the ratio of the speed of the extremities of a windmill rotor to the speed of the free wind. Drag devices always have tip-speed ratios less than one and hence turn slowly, whereas lift devices can have high tip-speed ratios (up to 13:1) and hence turn quickly relative to the wind. The proportion of the power in the wind that the rotor can extract is termed the coefficient of performance (or power coefficient or efficiency; symbol C_p) and its variation as a function of tip-speed ratio is commonly used to characterise different types of rotor. As mentioned earlier there is an upper limit of $C_p = 59.3\%$, although in practice real wind rotors have maximum C values in the range of 25%-45%. Solidity is usually defined as the percentage of the area of the rotor, which contains material rather than air. Low-solidity machines run at higher speed and tend to be used for electricity generation. High-solidity machines carry a lot of material and have coarse blade angles. They generate much higher starting torque (torque is the twisting or rotary force produced by the rotor than low-solidity machines but are inherently less efficient than low-solidity machines. The wind pump is generally of this type. High solidity machines will have a low tip-speed ratio and vice versa.

There are various important wind speeds to consider:

- Start-up wind speed - the wind speed that will turn an unloaded rotor
- Cut-in wind speed – the wind speed at which the rotor can be loaded
- Rated wind speed – the wind speed at which the machine is designed to run (this is at optimum tip-speed ratio)
- Furling wind speed – the wind speed at which the machine will be turned out of the wind to prevent damage
- Maximum design wind speed – the wind speed above which damage could occur to the machine

Anatomy and characteristics of the wind generator

A typical small wind generator has rotor that is directly coupled to the generator, which produces electricity either at 120/240 volt alternating current for direct domestic use or at 12/24 volt direct current for battery charging. Larger machines generate 3 phase electricity. There is often a tail vane which keeps the rotor orientated into the wind. Some wind machines have a tail vane, which is designed for automatic furling (turning the machine out of the wind) at high wind speeds to prevent damage. Larger machines have pitch controlled blades (the angle at which the blades meet the wind is controlled) which achieve the same function. The tower is of low solidity to prevent wind interference and is often guyed to give support to the tower.

Grid connected or battery charging

Depending on the circumstances, the distribution of electricity from a wind machine can be carried out in one of various ways. Commonly, larger machines are connected to a grid distribution network. This can be the main national network, in which case electricity can be sold to the electricity utility (providing an agreement can be made between the producer and the grid) when an excess is produced and purchased when the wind is low. Using the national grid helps provide flexibility to the system and does away with the need for a back-up system when windspeeds are low.

Micro-grids distribute electricity to smaller areas, typically a village or town. When wind is used for supplying electricity to such a grid, a diesel generator set is often used as a backup for the periods when wind speeds are low. Alternatively, electricity storage can be used but this is an expensive option. Hybrid systems use a combination of two or more energy sources to provide electricity in all weather conditions. The capital cost for such a system is high but subsequent running costs will be low compared with a pure diesel system. In areas where households are widely dispersed or where grid costs are prohibitively expensive, battery charging is an option. For people in rural areas a few tens of watts of power are sufficient for providing lighting and a source of power for a radio or television. Batteries can be returned to the charging station occasionally for recharging. This reduces the inconvenience of an intermittent supply due to fluctuating wind speeds. 12 and 24 volt direct current wind generators are commercially available which are suitable for battery charging applications. Smaller turbines (50 -150 watt) are available for individual household connection.

Environmental concerns

Wind power is a clean renewable energy source. There are, however some environmental considerations to keep in mind when planning a wind power scheme. They include the following:

- Electromagnetic interference - some television frequency bands are susceptible to interference from wind generators.
- Noise - wind rotors, gearboxes and generators create acoustic noise when functioning; this needs to be considered when siting a machine.
- Visual impact - modern wind machines are large objects and have a significant visual impact on their surroundings. Some argue that it is a positive visual impact, others to the contrary.

Lecture –28

Wind Power generation

Basic technology

Wind electric generator converts kinetic energy available in wind to electrical energy by using rotor, gear box and generator.

Wind Power

The terms "**wind energy**" or "**wind power**" describe the process by which the wind is used to generate **mechanical power or electricity**. Wind turbines convert the kinetic energy in the wind into mechanical power. This mechanical power can be used for specific tasks (such as grinding grain or pumping water) or a generator can convert this mechanical power into electricity to power homes, businesses, schools, and the like.

The seasonal as well as instantaneous changes in winds both with regard to magnitude and direction need to be well understood to make the best use of them in windmill designs. Winds are known to fluctuate by a factor of 2 or more within seconds (and thus causing the power to fluctuate by a factor of 8 or more). This calls for a proper recording and analysis of the wind characteristics.

There are various ways the data on wind behavior is collected depending on the use it is intended to be put into. The hourly mean wind velocity as collected by the meteorological observations is the basic data used in a windmill designs. The hourly mean is the one averaged over a particular hour of the day, over the day, month, year and years. The factors, which affect the nature of the wind close to the surface of the earth, they are:

- i) Latitude of the place,
- ii) Altitude of the place,
- iii) Topography of the place,
- iv) Scale of the hours, month or year.

Renewable Energy

Winds being an unsteady phenomenon, the scale of the periods considered is an important set of data required in the design. The hourly mean velocity (for many years) provides the data for establishing the potential of the place for tapping the wind energy. The scale of the month is useful to indicate whether it is going to be useful during particular periods of the year and what storage if necessary is to be provided for. The data based on scale of the hour is useful for mechanical aspects of design.

Since the winds near the surface of the earth are derived from large scale movement of atmospheric winds, the location height above ground level at which the wind is measured and the nature of the surface on earth have an influence on the velocity of wind at any given time. The winds near the surface of the earth are interpreted in terms of boundary layer concept, keeping in mind the factors that influence its development. The wind velocity at a given height can be represented in terms of gradient height and velocity.

The values of V_g , h_g and n depends on the nature of the terrain, which are classified as

- i) Open terrain with few obstacles (open land, lake, shores, deserts, prairies, etc).
- ii) Terrain with uniformly covered obstacles (wood lands, small towns, suburbs, etc.)
- iii) Terrain with large and irregular objects (large city centres, country with breaks of large trees etc.).

Components of wind electric generator

Basic components of a Wind Electric Systems are,

- Tower
- Nacelle
- Rotor
- Gearbox
- Generator

Renewable Energy

- Braking System
- Yaw System
- Controllers
- Sensors

The main components of a WECS are showing in Fig 1 in block diagram form. Summary of the system operation is as follows:

Aero turbines convert energy in moving air to rotary mechanical energy. In general, they require pitch control and yaw control (*only in the case of horizontal or wind axis machines*) for proper operation. A mechanical interface consisting of a step up gear and a suitable coupling transmits the rotary mechanical energy to an electrical generator. The output of this generator is connected to the load or power grid as the application warrants.

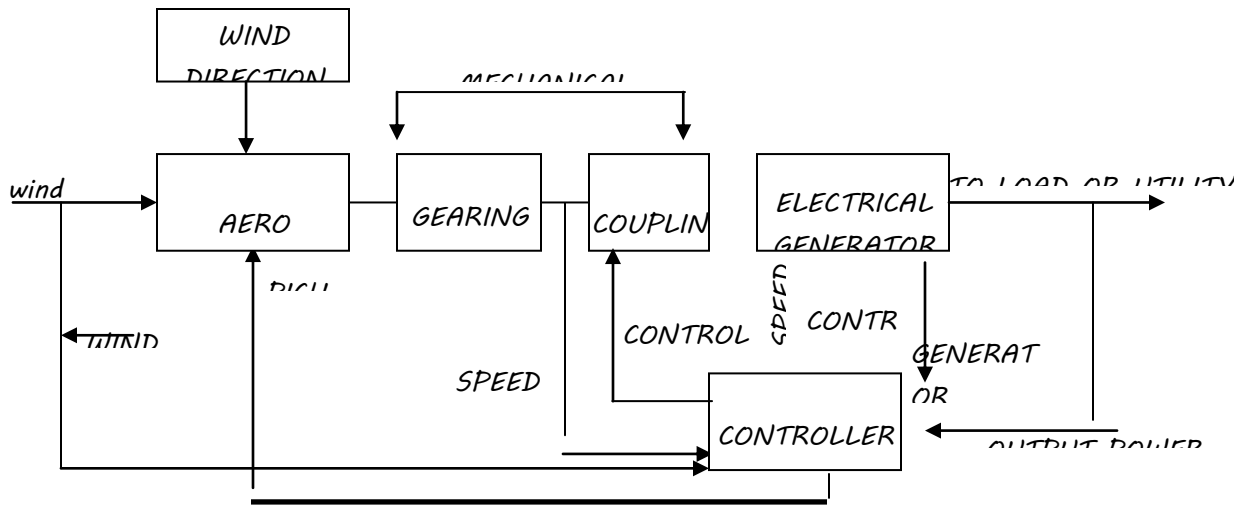

Yaw control. For localities with the prevailing wind in one direction, the design of a turbine can be greatly simplified. The rotor can be in a fixed orientation with the swept area perpendicular to the predominant wind direction. Such a machine is said to be yaw fixed. Most wind turbines, however, are yaw active, that is to say, as the wind direction changes, a motor rotates the turbine slowly about the vertical (or yaw) axis so as to face the blades into the wind. The area of the wind stream swept by the wind rotor is then a maximum.

In the small turbines, yaw action is controlled by tail vane, similar to that in a typical pumping windmill. In larger machines, a servomechanism operated by a wind-direction sensor controls the yaw motor that keeps the turbine properly oriented.

The purpose of the controller is to sense wind speed, wind direction, shafts speeds and torques at one or more points, output power and generator temperature as necessary and appropriate control signals for matching the electrical output to the wind energy input and protect the system from extreme conditions brought upon by strong winds electrical faults, and the like.

Renewable Energy

The physical embodiment for such an agro-generator is shown in a generalized. The sub-components of the windmill are:

- wind turbine or rotor
- wind mill head
- transmission and control and
- Supporting structure

Such a machine typically is a large impressive structure.

Rotors

- i. Horizontal axis rotor and
- ii. Vertical axis rotor.

One advantage of vertical-axis machines is that they operate in all wind directions and thus need no yaw adjustment.

The rotor is only one of the important components. For an effective utilization, all the components need to be properly designed and matched with the rest of the components.

Windmill head

The windmill head

It supports the rotor, housing the rotor bearings. It also houses any control mechanism incorporated like changing the *pitch* of the blades for safety devices and tail vane to orient the rotor to face the wind. Mounting it on the top of the supporting structure on suitable bearings facilitates the latter.

Transmission

Varying the pitch of the rotor blades, conveniently controls the rate of rotation of large wind turbine generator operating at rated capacity or below, but it is low, about 40 to 50 revolutions per minute (rpm). Because optimum generator output requires much

greater rates of rotation, such as 1800 rpm, it is necessary to increase greatly the low rotor rate of turning. Among the transmission options are mechanical systems involving fixed ratio gears, belts, and chains, singly or in combination or hydraulic systems involving fluid pumps and motors. Fixed ratio gears are recommended for top mounted equipment because of their high efficiency, known cost, and minimum system risk. For bottom mounted equipment which requires a right-angle drive, transmission costs might be reduced substantially by using large diameter bearings with ring gears mounted on the hub to serve as a transmission to increase rotor speed to generator speed. Such a combination offers a high degree of design flexibility as well as large potential savings.

Generator

Either constant or variable speed generators are a possibility, but variable speed units are expensive and/or unproved. Among the constant speed generator candidates for use are synchronous induction and permanent magnet types. The generator of choice is the synchronous unit for large aero generator systems because it is very versatile and has an extensive database. Other electrical components and systems are, however, under development.

Controls

The modern large wind turbine generator requires a versatile and reliable control system to perform the following functions:

- 1) the orientation of the rotor into the wind (azimuth of yaw);
- 2) start up and cut-in of the equipment;
- 3) power control of the rotor by varying the pitch of the blades;
- 4) generator output monitoring - status, data computation, and storage;
- 5) shutdown and cut out owing to malfunction of very high winds'
- 6) protection for the generator, the utility accepting the power and the prime mover;
- 7) auxiliary and /or emergency power; and
- 8) maintenance mode.

Renewable Energy

Many combinations are possible in terms of the control system and may involve the following components:

- 1) Sensor - mechanical, electrical, or pneumatic:
- 2) Decision elements - relays, logic modules, analog circuits, a microprocessor, a fluidics, units, or a mechanical unit; and
- 3) Actuators - hydraulic, electric, or pneumatic. A recommended combination of electronic transducers feeding into a micro-processor which, in turn, signals electrical actuators and provides protection through electronic circuits, although a pneumatic slip clutch may be required.

Towers.

Four types of supporting towers deserve consideration, these are:

- 1) the reinforced concrete tower
- 2) the pole tower
- 3) the built up shell-tube tower, and
- 4) the truss tower

Among these, the truss tower is favoured because it is proved and widely adaptable, cost is low, parts are readily available, it is readily transported, cost is low, parts are readily available, it is readily transported, and it is potentially stiff. Shell-tube towers also have attractive features and may prove to be competitive with truss towers.

The type of the supporting structure and its height is related to cost and the transmission system incorporated. It is designed to withstand the wind load during gusts (even if they occur frequently and for very short periods). Horizontal axis wind turbines are mounted on towers so as to be above the level of turbulence and other ground related effects. The minimum tower height for a small WECS is about 10m, and the maximum practical height is estimated to be roughly 60 m.

The turbine may be located either upwind or downwind of the tower. In the upwind location (i.e. the wind encounters the turbine before reaching the tower), the

Renewable Energy

wake of the passing rotor blades causes repeated changes in the wind forces on the tower. As a result, the tower will tend to vibrate and may eventually be damaged. On the other hand, if the turbine is down wind from the tower as shown in figure, the tower vibrations are less but the blades are now subjected to severe alternating forces as they pass through the tower wake.

Both upwind and downwind locations have been used in WEC devices. Downwind rotors are generally preferred especially for the large aero generators. Although other forces acting on the blades of these large machines are significant, tower effects are still important and tower design is an essential aspect of the overall system design.

Water pumping

The sun converts five million tonnes of matter into energy every second. The tiny fraction of energy reaching earth occurs in many forms. One of these is wind energy. Wind energy is extraction of kinetic energy from the wind for conversion into a useful type of energy - mechanical or electrical. The use of wind energy is almost as old as recorded history. Windmills along with watermills were among the original prime movers that replaced animal muscle as a source of energy.

Two important aerodynamic principles are utilized in windmill operation, i.e., lift and drag. The wind can rotate the rotor of a wind mill either by lifting (lift) the blades or by simply pushing against it (drag). Practically a wind mill cannot extract all the power in the wind as it depends upon many factors like the density of the air, wind speed, atmospheric pressure, area of the rotor and design of the rotor. To extract and utilize the maximum possible energy, two principles (lift and drag) are well adjusted while designing a wind mill for a specific application.

There are two different types of wind machines

1. Horizontal –axis wind machine where the rotating axis is parallel to the direction of wind flow and parallel to the ground. There are two or more aerodynamic blades mounted on the horizontal shaft. The blade tips can travel at several times the wind speed

which results in high efficiency. The blade shape is designed by using the same aerodynamic theory as for aircraft. The low-speed horizontal axis wind mills are used mainly for mechanical purposes, like in water pumps.

2. Vertical – axis wind machines are those where the rotating axis is perpendicular to the wind stream and to the ground. The best known vertical-axis rotor is made up of two identical semi cylinders with their axis vertical. This was developed by the Finnish engineer, Savonius (1931), and is being used increasingly for small wind – energy installations. The French engineer, Davieus designed another type of vertical – axis rotor called Davious type wind mill. Flexible metal strips in the shape of a catenary form the rotor blades. For a given wind speed, the unit rotates more rapidly and is more efficient than the savonius rotor. Unfortunately, the Darreieus rotor is not self-starting even in high winds.

Water pumping wind mills – a viable alternative

The energy needs of the agricultural sector have been on the rise with the introduction of improved farming technologies and increased mechanization. The electrical power needs of the agricultural sector have risen to almost 40 per cent of the total power consumption in the state. The heavy state subsidies, concessional and flat tariffs given to the sector for conventional electric power act as a disincentive for renewable energy source or energy conservation and along with the increasing rise in demand, strain the already taxed power situation in this country.

Wind pumping is a well-established technology that offers an alternative to diesel and electric pumpsets. Most wind pumps can operate under fairly low wind conditions (6-8 kmph) and are especially appropriate for the modest water needs of small farming establishments. Storing water is also cheaper than storing electricity. During low wind periods the owner can simply draw on the water that was pumped into the storage tank when the wind was ample.

Most mechanical wind machines use fan type blades, which can range from a minimum of 4 to a maximum of 24 blades to capture the wind energy, which is then transferred by a drive shaft to the pumping mechanism. Today gear type windmills are

Renewable Energy

promoted under the National water pumping wind mill programme as they are easier for operation and maintenance.

Wind is a highly variable energy resource. The user cannot control its timing or intensity. A strong wind may cause the storage tank to over flow, while a weak wind might not provide enough water for the user's needs. Effective use of the wind pump depends on a clear matching of demand and supply facilitated both by matching the design of the wind pump (its water output etc.) to suit the user's needs, and the user himself learning to use the wind pump and the stored water effectively.

In areas where electricity lines have not yet reached or where the supply is erratic and diesel supplies are expensive and unreliable, wind pumps have ensured water for man, animals and land.

The annual operation and maintenance cost of a wind pump in total averages at about Rs. 500-700. This is besides the oiling and moving parts (twice a month), changing the washers (between 1-3 years, depending on the use) and changing the oil in the gear box (once a year). Preventive maintenance is crucial to the smooth and regular working of the wind pumps, to check downtime.

In the coming years, research and development one going to play a pivotal role in the acceptance of the wind pump technology on a scale that can meet the requirement of large, agro-economic developing country like India. Problems to be tackled will primarily have to do with increasing water output and lessening maintenance headache.

Wind mill for water pumping

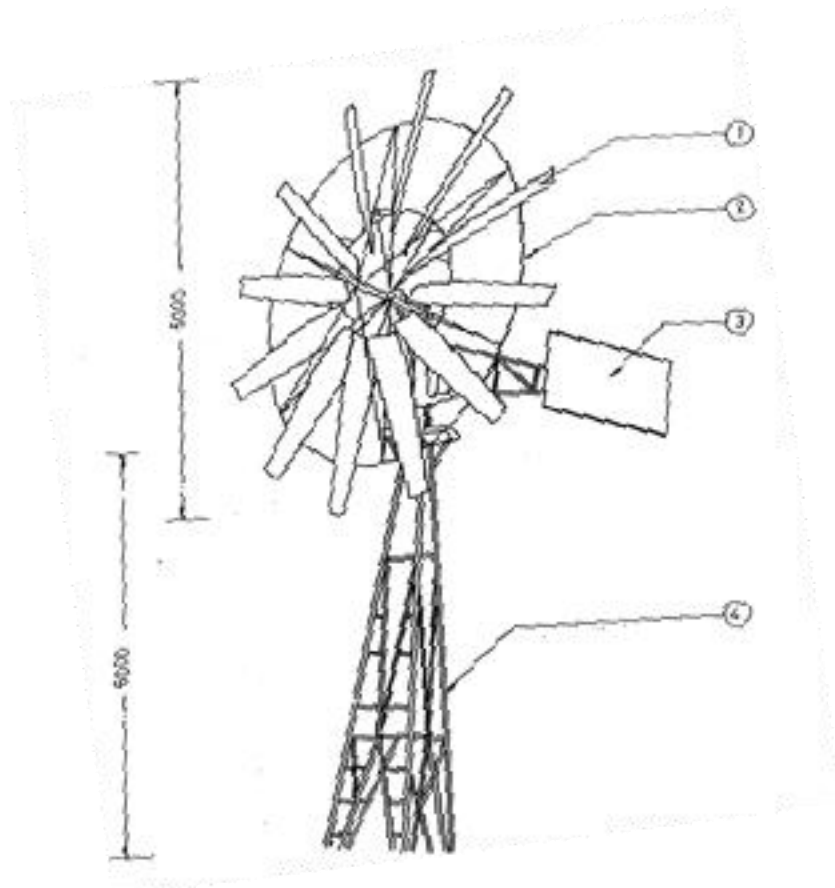

1. Vane 2. Rotor 3. Tail 4. Tower

The reciprocating pump is fitted at 25 m. depth in a bore well. The vanes are reinforced with 25 x 25 x 8 mm. size L angles at the backside of the periphery for longevity.

Salient Features

- The discharge rate at 14 to 25 km/h wind velocity is 3,000 to 4,750 litre/h.
- This can be used for medium wind speed areas (10-14 km/h).

Lecture-33

Energy Conservation in agriculture

India is currently following a development path which aims to remove income and energy poverty of millions of households. As a result, energy requirements of the country are expected to rise. While India's energy intensity is on a decline due to structural changes in the economy and improvement in energy efficiency, overall energy requirements would grow due to growth in economic activity. For the power sector alone, the generation capacity should reach 8,00,000 MW by 2031-32, nearly a five-fold rise from the current levels (GOI, 2006). The Indian power sector offers a lot of scope to improve on existing efficiencies in generation, distribution and utilization of electricity. The resultant savings in fossil fuel consumption would translate to a large potential for reductions in associated carbon emissions. The per capita electricity consumption in India is recorded to be 704.2 kWh in 2007-08. This is quite low as compared to the that recorded in 2006 for China (2041), high income OECD countries (9774), high income countries (9675) and the world average (2751) (World Bank, 2009). A large proportion of the Indian population continues to face income as well as energy poverty. In the future, electricity consumption per capita is likely to rise to meet the basis needs of those not served with electricity. Furthermore, increasing economic activity would place a greater demand for energy resources. In the past, investment in capacity expansion, extension of the distribution network and end-use appliances was based on least cost. This was often at the expense of energy efficiency. This approach was partly influenced by a lack of financial resources, but also by a lack of institutional capacity and absence of incentives in electricity pricing. Although significant progress is being made to introduce efficient technology and to improve operational performance in the power sector, efforts are limited due to financial scarcity as well as institutional constraints (Singh, 2009). The pricing anomalies in the power sector have been addressed in general by the SERCs to a varying degree. However, political compulsions continue to shield subsidized tariff for agricultural consumers across the country.

Energy scarcity, along with the local and global environmental impacts of energy use emphasise the need to speedily address inefficiencies in the power sector. However, numerous barriers including financial, technical as well as institutional exist and which impede the achievement of this objective. Singh (2009) discusses opportunities for efficiency improvements in the power sector and identifies the following three climate cobenefit policies; (i) adoption of efficient agricultural pump sets. (ii) modernization of the low tension (LT) distribution network to High Voltage Distribution System (HVDS) and (iii) adoption of clean and efficient coal-based generation technology. In spite of the known benefits of such policies, the progress thereof is rather limited, suggesting that the above mentioned barriers are hampering policy implementation. This paper attempts to identify the challenges in implementing a policy for nationwide programme to adopt efficient agricultural pump sets. Due to the presence of technical as well economic efficiencies associated with the policy, this exercise would offer a wider perspective amongst the three policies. India adopted a National Action Plan for Climate Change (NAPCC) last year. It proposed eight national missions with

climate related benefits including a National Mission on Enhanced Energy Efficiency (NME3) which has recently been approved (in-principle) by the Indian Prime Minister. Apart from this, the Bureau of Energy Efficiency (BEE) has initiated large pilot projects under the Agricultural Demand Side Management (AgDSM) programme. This aims to reduce electricity consumption for irrigation by enhancing the efficiency of pump sets. This is discussed further in the next section. The main objective of this paper is to assess stakeholders' perspectives, through a survey, on implementing a nation-wide policy for adoption of efficient agriculture pumps. This Further, the policy related to adoption of efficient agricultural pump sets also entails HVDS investment as a prerequisite. This is discussed further in the next section.

Policy for Adoption of Efficient Agricultural Pump Sets

The policy recommendation is to implement a joint programme for replacement of inefficient agricultural pump sets (including motor/engine and pump assemblies, piping, foot valves etc.) along with mandatory electronic metering of their electrical connections. Such a program should be supplemented with feeder metering and system modernization of the low tension (LT) distribution network with a High Voltage Distribution System (HVDS). The distribution companies (discoms) should also undertake separation of rural feeders with partial support from Restructured Accelerated Power Development and Reforms Programme (R-APDRP). Irrigation pumps used in the agriculture sector account for about 25% of electricity consumption in India. This share is reported to be 48.89% in Gujarat, 43.39% in Haryana and 42.27 % in Karnataka. Due to subsidised tariffs, agricultural consumers contribute only a little to the revenue of utilities. Farmers, who pay HP-based flat rates irrespective of their electricity use, perceive zero marginal cost for electricity use and, hence, disregard efficiency in consumption. This is reflected in purchase preference for cheap but inefficient pumps. Various pilot studies have revealed the poor level of energy efficiency of these pumps. An energy audit of electrical pump sets at four field study locations in Haryana average pump set efficiency was found to be only 21-24% (World Bank, 2001). The study also found that only 2% of the pumps surveyed had efficiency levels above 40%. Phadke et al. (2005) find that a DSM program for replacing inefficient agricultural pumps in Maharashtra would be cost effective by lowering the short-run cost of electricity generation in the state. More recently, an energy audit of a sample of pump sets at Doddaballapur Taluk of Bangalore Rural District in Karnataka was conducted under the Water and Energy Nexus (WENEXA) Project of the USAID. The study revealed that 91 per cent pumps were operating at the efficiency of less than 30 per cent (Oza, 2007). Subsidised tariffs for agriculture and domestic consumers are supported partly by budget subsidies from respective state governments. In 2007-08, this was estimated to be Rs. 141.6 billion (GOI, 2008). Apart from this, the SERCs continue to rely on cross subsidisation of tariffs by charging higher tariffs from industrial and commercial consumers to support lower tariffs for agriculture and domestic consumers. Flat pricing of electricity and unmetered supply continues to shield inefficiency in consumption and obscures operational efficiency of utilities. A policy to enhance efficiency of pump sets, to meter such consumption and to price electricity efficiently would have wider implications for the sector and beyond. A reduction in subsidy

requirement for the power sector would allow state governments to channel the funds to other social sectors including education, primary health and rural infrastructure. In this context, Singh (2009) proposed a national programme for adoption of efficient pumps for agricultural use to moderate the impact of above mentioned institutional inefficiencies.

INTERNATIONAL SUPPORT FOR DOMESTIC ACTION

We constructed alternate policy scenarios for varying degree of adoption of efficient pump sets by farmers. It is assumed that number of agricultural pump sets would grow to 20 million by 2011-12. In efficient scenarios, all new pump sets are expected to be efficient and hence require less number of hours of operation, and have 10% lower rated output. Similar is the case for all pump set replacements. The transmission and distribution (T &D) losses are expected to fall from 32.25% in 2007-08 to 25% by 2011-12. In a conservative scenario with little penetration of efficient pumps, it was estimated that about 5% reduction in carbon emissions can be achieved. In the case of an aggressive pump replacement scenario, a reduction in carbon emissions of up to 30% can be achieved.

There are multiple benefits for the power sector utilities as well. A lower demand for power from the agriculture sector would improve consumption profile towards better paying customers and, hence, would improve revenue realization per unit of electricity. Agricultural loads are rather spread out and hence incur higher technical losses. A change in consumption pattern away from agriculture could lower overall technical losses for the distribution utilities. It is often argued that due to the absence of metering, part of T & D losses are often camouflaged as consumption in the agriculture sector. Better metering and energy accounting would certainly help in bringing more transparency in the system. These are expected to improve operational as well as financial performance of distribution utilities. In the long-run, these changes would provide a conducive environment for efficiently pricing the electricity in a manner which provides incentive for energy conservation. A lower demand for electricity would necessitate lower investment for generation capacity addition in the sector in the long-run.

Drivers and Key Stakeholders: Agricultural Pump Set Replacement

Identification of drivers a policy implementation empowers the policy makers as well as the implementing agencies to commit resources. The importance of key drivers for implementing a nation-wide policy for pump set replacement would also assist in identifying benefits to various stakeholders and thus seek their cooperation and commitment. It is often noted that a lack of institutional capacity has resulted in failure of various public programmes both within and outside the energy sector. The most important drivers that support implementation of the suggested policy are identified as:

- Energy savings
- Reduced pressure on groundwater reservoirs
- Ability to manage tariff subsidy
- Enhanced transparency and accounting of energy consumption

Renewable Energy

- Facilitation of appropriate tariff design

It is important to note that benefits of the policy go beyond the power sector and has other environmentally benign outcomes, like by easing pressure on groundwater reservoirs. Due to lack of consumer metering and energy accounting, system losses have been camouflaged as high consumption in the agricultural sector (Singh, 2006). Improved transparency and energy accounting would not only plug revenue leakages, but may also reduce the tariff subsidies from state governments. The respondents to the survey identify the respective state governments as the most important actors for the implementation of this policy. This was followed by the distribution companies, central government and regulatory institutions. Furthermore, the respondents also identified a role for associated ESCOs / implementing agencies, who would undertake projects for replacement of inefficient pump sets. Given the crucial role to be played by state level entities, a clear recommendation would be to strengthen institutional capacity with state-level agencies to successfully implement such a programme.

USDA's Cooperative State Research, Education, Extension and Service (CSREES)

leverages the nationwide expertise housed at land grant universities. CSREES provides funding for about 60 projects that include an energy-related objective. The goals of these projects include:

- Reducing costs associated with the conversion of biomass to energy and industrial products,
- Increasing biobased product inventories to replace petroleum based products,
- Developing technologies for effectively converting agricultural (including forestry) residuals into energy and products,
- Developing cost effective biocatalysts capable of converting lignocellulosic materials economically, effectively and with low environmental impact, and
- Identifying unique biomass feedstocks for the sustainable production of bioenergy and industrial products.

USDA's Farm Service Agency (FSA) administers the Conservation Reserve Program (CRP) and the CCC Bio-Energy Program. The CRP was established by the Food Security Act of 1985 to assist owners and operators in conserving and improving soil, water, and wildlife resources on their farms and ranches by converting highly erodible and other environmentally sensitive cropland and marginal pasture to long-term resource conserving covers. Participants enrol cropland in the CRP for a period from 10 to 15 years in exchange for annual rental payments and cost-share assistance for installing certain conservation practices. Enrollment of up to 39.2 million acres is authorized, and there are currently about 36 million acres under contract.

CRP lands sequester significant amounts of carbon dioxide in soils and vegetative cover and many CRP lands have the potential to be used for the production of bioenergy crops, such as

Renewable Energy

switchgrass, willows, and poplars. A 2003 analysis, for example, estimated that 13 million acres of cropland enrolled in the CRP could produce an average of about 4 tons of biomass per acre (dry matter) or over 50 million tons of biomass annually. The 2002 Farm Bill specifies the conditions under which CRP enrolled acreage can be utilized for biomass production. First, harvesting must be consistent with conservation of soil, water quality, and wildlife habitat, and second, payments must be reduced commensurate with the economic value of the biomass produced. Under CRP's Biomass Pilot Program established in 2000, USDA approved the use of CRP land in 4 projects located in 4 States. The programs approved include one each in Minnesota (hybrid poplars), New York (willows), Iowa (switchgrass), and Pennsylvania (switchgrass). Projects were also approved in Oklahoma and Illinois.

The CCC Bioenergy Program began on December 1, 2000, and ended on June 30, 2006. Under the program, cash payments were made to bioenergy producers who increase their annual bioenergy production from eligible agricultural commodities. Eligible commodities included barley, corn, grain sorghum, oats, rice, wheat, soybeans, other oilseeds, cellulosic crops, and animal fats and oils. From December 2000 through March 2006, the program reimbursed bioenergy producers \$537 million for 2.5 billion gallons of increased ethanol production, 146.4 million gallons of increased biodiesel production, and 26.7 million gallons of base biodiesel production.

USDA's Office of Energy Policy and New Uses administers the Federal Biobased Preferred Products Procurement Program (FB4P), the USDA Certified Biobased Product Labeling Program and Biodiesel Education Program (BEP). All three programs were created by the 2002 Farm Bill. Under the FB4P, Federal agencies will be required to give procurement preference to qualified biobased products if the products are available, meet performance standards, and are available at costs similar to their non-biobased counterparts. Biobased products are defined as commercial or industrial products that are composed, in whole or in significant part, of biological products or renewable domestic agricultural materials (including plant, animal, and marine materials) or renewable forestry materials. The first in a series of rules to designate items for preferred procurement was published as a final rule in March 2006. Six items were designated for preferred procurement by this rule: mobile equipment hydraulic fluids, biobased roof coatings, water tank coatings, diesel fuel additives, penetrating lubricants and, bedding, bed linens and towels. The 2002 Farm Bill also provides for a voluntary program authorizing producers of qualified biobased products to use a "USDA Certified Biobased Product" label and logo to identify qualified products. The 2002 Farm Bill authorized funding of \$1 million per year from FY 2003-07 for education grants under the BEP. Under BEP, two competitive grants were awarded to the National Biodiesel Board and the University of Idaho to educate the public, and government and private entities that operate vehicle fleets on the benefits of using biodiesel. Program funds have been used for organizing national conferences, conducting technical workshops, and distributing educational materials, including manuals on quality control. Many partnerships with other groups and government agencies have been formed to share information, leverage resources, coordinate activities, and avoid program redundancies. In addition to ethanol and biodiesel, biomass and animal wastes can be used to produce renewable energy. Biomass is used to

Renewable Energy

generate electric power by direct burning, using gasification systems, or mixing biomass with coal in coal-fired electrical generation facilities.

The primary feedstocks include wood waste used by the pulp and paper industry for industrial heat and steam production. In addition, forest residues and municipal solid waste are used to generate electricity. Another potentially large source of renewable energy is animal waste which can be turned into methane gas through anaerobic digestion. Anaerobic digesters are being adopted by commercial livestock operations not only to produce energy, but also to meet new state and Federal regulations for controlling animal waste. Currently, there are over 90 anaerobic digester projects, either in operation or under construction, located throughout the United States. Nearly all the anaerobic digesters are associated with dairy operations, with a few associated with swine or poultry operations. Another emerging approach to reducing U.S. fossil energy use is to replace petroleum based products with products made from biomass. There are many industrial and consumer products that have been traditionally made from biomass, including yarns and fabrics, soaps and detergents, pulp and paper, lubricants and greases, and adhesives and paints. However, agricultural feedstocks can be used to produce non-traditional products such as chemicals, plastics, hydraulic fluids, and pharmaceuticals. There are many agricultural feedstocks that can be used to make bioproducts, including a variety of crops, wood and plant oils, and agricultural and forestry residues. Bioproducts often require less energy to produce than the fossil and inorganic products they replace. With the increasing costs of fossil fuels, U.S. industries have an increased incentive to consider and produce alternative bioproducts. As examples of new biobased technology, corn starch is being used to produce bioplastic products, and soybeans are being used to produce a polymer used to manufacture carpet backings. The chemical industry could potentially offer a large market for numerous high-value biobased chemicals and other materials made from agriculture.

Progress is also being made in developing energy from solar, wind, and geothermal resources although the amount of energy from these sources is relatively small. Small-scale solar applications are already commercially available that provide electricity for lighting, battery charging, water pumping, and electric fences. There also has been an emergence of large-scale solar technology that is being used in homes and in the industrial sector. Small-wind systems are currently being developed to generate electricity in remote areas and utility-size turbines have been increasing in numbers, especially on farms in areas with consistently high wind speeds. More geothermal resources are being tapped to produce electrical or thermal energy in local areas. There are many agricultural applications for geothermal energy, including heating greenhouses, providing warm water for aquaculture operations, and drying produce. Although ethanol growth has been impressive in recent years, ethanol accounts for about 3 percent of total annual gasoline consumption. About 14 percent of the U.S. corn crop was used for ethanol in 2005/06 and USDA projects 20 percent of U.S. corn production will be converted into ethanol in 2006/07. Clearly, the supply of corn is relatively small compared to gasoline demand, so other domestic sources of renewable energy must be developed to replace oil imports if the U.S. is to greatly reduce its dependence on imported oil. Biodiesel can extend the diesel fuel supply, but the supply of oil crops, animal fats, and other

Renewable Energy

feedstocks are also relatively small compared to the diesel fuel market. Research may provide technological breakthroughs leading to a significant expansion in ethanol production. In the near future, ethanol's feedstock base could expand significantly with the advancement of technology that could economically convert switch grass and other low-valued biomass into cellulosic ethanol.

USDA's Forest Service (FS) also plays a major role in energy production and conservation. The FS is working to increase production of all energy sources in an environmentally sound manner, capitalizing on the potential of woody biomass as a renewable energy resource, and contributing to the improvement of infrastructure for transmitting energy across the country. Increasing domestic energy supply includes providing energy facility corridors, ensuring that lands are available for energy mineral development and production, developing renewable energy resources such as woody biomass, wind, solar power, and geothermal energy, and relicensing hydropower facilities. Nearly 50 percent of the nation's geothermal energy production comes from Federal lands. There are currently 354 federal geothermal leases, 116 on National Forest lands, covering nearly 360,000 acres. At the present time, there are 5 producing leases on National Forest lands contributing to a 12 mega-watt plant and a 45 mega-watt power plant that, combined, have resulted in more than \$12 million in royalties.

The FS actively participates in a government-wide initiative aimed at promoting development and use of biobased products and bioenergy. Programs include research on enhancing opportunities to use forest biomass to produce energy and other value-added products; developing economical, environmentally acceptable woody cropping systems to produce energy and other value-added products; exploring new processes to convert wood into ethanol; and identifying ways to increase energy conservation through changes in manufacturing technologies, harvesting technologies, building construction practices, and designed landscapes.

The focus of the FS Biomass and Bioenergy efforts is woody materials that are not part of the commercial forest product material flows. Woody biomass includes forest vegetation treatment residuals (tree limbs, tops, needles, leaves and other woody parts) that are by-products of forest management and ecosystem restoration. Currently these materials are underutilized, commercial value is low, and markets are small to non-existent.

A recent joint USDA and DOE report, *Biomass as Feedstock for a Bioenergy and Bioproducts Industry: The Technical Feasibility of a Billion-Ton Annual Supply*, commonly known as the "Billion Ton Report," projects that there are over 1.3 billion dry tons per year of biomass potential, enough to produce biofuels sufficient to meet more than one-third of the nation's current demand for transportation fuels by 2030. About one-quarter of that total, roughly 380 million dry tons of biomass could be produced in a sustainable manner from residues from private, State, Tribal and Federal forest lands and from forest wood wastes.

The Healthy Forest Restoration Act (HRRA) authorized the use of \$5 million to help "establish small-scale business enterprises to make use of biomass and small-diameter material." These funds were to be used to: (1) help reduce forest management costs on

National Forest System lands by increasing the value of biomass and other forest products generated from hazardous fuel treatments; (2) create incentives and/or reduce business risk for increased use of biomass from or near national forestlands; (3) institute projects that target and help remove economic and market barriers to using small-diameter trees and wood biomass.

Effects on Renewable Energy Production and Energy Efficiency

Federal and State governments have helped create markets for renewable energy through tax incentives and mandates. Ethanol production has increased sharply since the late 1990s, to 4 billion gallons in 2005 up from 1.8 billion gallons in 2001. Biodiesel production has grown to over 90 million gallons in 2005, a nine-fold increase from 2001. The EPACT mandates that 7.5 billion gallons of renewable energy be used in motor vehicles by 2012, guaranteeing a future demand for the renewable fuels. In addition to Federal and State programs, high oil prices and the phase out of MTBE have contributed to the growth in renewable fuels production since 2001. While modest in size compared with tax incentives, USDA programs have contributed to this growth. RD grants, loans, and loan guarantee programs supported the planning and construction of new production facilities and energy conservation projects, creating jobs and additional wealth enhancing opportunities in rural America. In total, 650 renewable energy and energy efficiency projects have been funded between FY 2001-05 at a Federal cost of \$356 million. In addition, matching and funding by the private sector supporting these projects totaled another \$1.3 billion. Included in these programs are 132 ethanol and biodiesel, 130 wind, 20 solar, 4 geothermal, 2 hydrogen, and 11 hybrid projects; 92 anaerobic digesters and 7 landfill gas recover systems; 168 energy efficiency projects; and other projects including solid fuel research.

In 2005, additional conservation practices applied with the assistance of USDA that improved energy efficiency on farms and ranches included:

- Residue management on 4.5 million acres,
- Irrigation water management on 1.2 million acres,
- Nutrient management on 4.1 million acres, and
- Pesticide management on 3.9 million acres.

There is a significant opportunity to realize immediate economic and environmental gains through energy conservation activities. Preliminary estimates of the potential national savings from implementing the following five conservation measures could be greater than \$2 billion per year. The measures include:

- Doubling of no-till acreage (from 62 to 124 million acres), saving 217 million gallons of diesel fuel and \$500 million each year;
- Switching from high or medium pressure systems to low pressure systems, lowering electricity use, and saving \$100 million in pumping irrigation water costs;
- Increasing diesel irrigation pump efficiency by 10-percent, reducing diesel consumption by almost 26 million gallons, and saving farmers and ranchers almost \$60 million each year;

Renewable Energy

- Doubling manure-based nitrogen use to replace fertilizer produced from natural gas valued at \$825 million and 100 billion cubic feet of natural gas annually; and
- Using precision agriculture on more acres to reduce application overlap on 250 million acres of cropland, saving up to \$825 million in fertilizer and pesticide costs each year.

In addition to ethanol and biodiesel, biomass and animal wastes can be used to produce renewable energy. Biomass is used to generate electric power by direct burning, using gasification systems, or mixing biomass with coal in coal-fired electrical generation facilities. The primary feedstocks include wood waste used by the pulp and paper industry for industrial heat and steam production. In addition, forest residues and municipal solid waste are used to generate electricity. Another potentially large source of renewable energy is animal waste which can be turned into methane gas through anaerobic digestion. Anaerobic digesters are being adopted by commercial livestock operations not only to produce energy, but also to meet new state and Federal regulations for controlling animal waste. Currently, there are over 90 anaerobic digester projects, either in operation or under construction, located throughout the United States. Nearly all the anaerobic digesters are associated with dairy operations, with a few associated with swine or poultry operations. Another emerging approach to reducing U.S. fossil energy use is to replace petroleum based products with products made from biomass. There are many industrial and consumer products that have been traditionally made from biomass, including yarns and fabrics, soaps and detergents, pulp and paper, lubricants and greases, and adhesives and paints. However, agricultural feedstocks can be used to produce non-traditional products such as chemicals, plastics, hydraulic fluids, and pharmaceuticals. There are many agricultural feedstocks that can be used to make bioproducts, including a variety of crops, wood and plant oils, and agricultural and forestry residues.

Meet expected new demands for rural electric generation and transmission.

Demand for new electric power generation capacity is building, after many years of little or no new base load capacity being added. Substantial increases in loan guarantee demands are expected. While USDA loan guarantees typically are for 95-100 percent of the loan, consideration may be given to develop a more traditional loan guarantee program for private lenders and use partial loan guarantees or create a mechanism for lenders to bid for the level of guarantee they would require to provide financing. Loan guarantees and planning grants could be targeted to support the development of distributed generation facilities using biobased fuel, wind, solar, or geothermal resources. Often the distribution grid must be augmented to accommodate the renewable or distributed generation power. Loan guarantee authority to support projects to upgrade the grid would help build renewable energy capacity. High voltage transmission capacity to move renewable energy from its source to demand locations is a serious constraint to renewable power development. Clarifying access rights and pricing for high voltage transmission could also be helpful in facilitating needed transmission development.



This Book Download From e-course of ICAR
**Visit for Other Agriculture books, News,
Recruitment, Information, and Events at**
WWW.AGRIMOON.COM

Give FeedBack & Suggestion at info@agrimoon.com

DISCLAIMER:

The information on this website does not warrant or assume any legal liability or responsibility for the accuracy, completeness or usefulness of the courseware contents.

The contents are provided free for noncommercial purpose such as teaching, training, research, extension and self learning.

